

# Welded Steel Tanks for Oil Storage

API STANDARD 650  
TENTH EDITION, NOVEMBER 1998

ADDENDUM 1, JANUARY 2000  
ADDENDUM 2, NOVEMBER 2001



**Helping You  
Get The Job  
Done Right.<sup>SM</sup>**



# Welded Steel Tanks for Oil Storage

## Downstream Segment

API STANDARD 650  
TENTH EDITION, NOVEMBER 1998

ADDENDUM 1, JANUARY 2000  
ADDENDUM 2, NOVEMBER 2001



**Helping You  
Get The Job  
Done Right.<sup>SM</sup>**

## SPECIAL NOTES

API publications necessarily address problems of a general nature. With respect to particular circumstances, local, state, and federal laws and regulations should be reviewed.

API is not undertaking to meet the duties of employers, manufacturers, or suppliers to warn and properly train and equip their employees, and others exposed, concerning health and safety risks and precautions, nor undertaking their obligations under local, state, or federal laws.

Information concerning safety and health risks and proper precautions with respect to particular materials and conditions should be obtained from the employer, the manufacturer or supplier of that material, or the material safety data sheet.

Nothing contained in any API publication is to be construed as granting any right, by implication or otherwise, for the manufacture, sale, or use of any method, apparatus, or product covered by letters patent. Neither should anything contained in the publication be construed as insuring anyone against liability for infringement of letters patent.

Generally, API standards are reviewed and revised, reaffirmed, or withdrawn at least every five years. Sometimes a one-time extension of up to two years will be added to this review cycle. This publication will no longer be in effect five years after its publication date as an operative API standard or, where an extension has been granted, upon republication. Status of the publication can be ascertained from the API Standards Department [telephone (202) 682-8000]. A catalog of API publications and materials is published annually and updated quarterly by API, 1220 L Street, N.W., Washington, D.C. 20005.

This document was produced under API standardization procedures that ensure appropriate notification and participation in the developmental process and is designated as an API standard. Questions concerning the interpretation of the content of this standard or comments and questions concerning the procedures under which this standard was developed should be directed in writing to the director, Standards Department, American Petroleum Institute, 1220 L Street, N.W., Washington, D.C. 20005, standards@api.org. Requests for permission to reproduce or translate all or any part of the material published herein should be addressed to the publications manager at publications@api.org.

API standards are published to facilitate the broad availability of proven, sound engineering and operating practices. These standards are not intended to obviate the need for applying sound engineering judgment regarding when and where these standards should be utilized. The formulation and publication of API standards is not intended in any way to inhibit anyone from using any other practices.

Any manufacturer marking equipment or materials in conformance with the marking requirements of an API standard is solely responsible for complying with all the applicable requirements of that standard. API does not represent, warrant, or guarantee that such products do in fact conform to the applicable API standard.

*All rights reserved. No part of this work may be reproduced, stored in a retrieval system, or transmitted by any means, electronic, mechanical, photocopying, recording, or otherwise, without prior written permission from the publisher. Contact the Publisher, API Publishing Services, 1220 L Street, N.W., Washington, D.C. 20005.*

Copyright © 2001 American Petroleum Institute

## FOREWORD

This standard is based on the accumulated knowledge and experience of purchasers and manufacturers of welded steel oil storage tanks of various sizes and capacities for internal pressures not more than 2<sup>1</sup>/<sub>2</sub> pounds per square inch gauge. This standard is meant to be a purchase specification to facilitate the manufacture and procurement of storage tanks for the petroleum industry.

If the tanks are purchased in accordance with this standard, the purchaser is required to specify certain basic requirements. The purchaser may want to modify, delete, or amplify sections of this standard, but reference to this standard shall not be made on the nameplates of or on the manufacturer's certification for tanks that do not fulfill the minimum requirements of this standard or that exceed its limitations. It is strongly recommended that any modifications, deletions, or amplifications be made by supplementing this standard rather than by rewriting or incorporating sections of it into another complete standard.

The design rules given in this standard are minimum requirements. More stringent design rules specified by the purchaser or furnished by the manufacturer are acceptable when mutually agreed upon by the purchaser and the manufacturer. This standard is not to be interpreted as approving, recommending, or endorsing any specific design or as limiting the method of design or construction.

This standard is not intended to cover storage tanks that are to be erected in areas subject to regulations more stringent than the specifications in this standard. When this standard is specified for such tanks, it should be followed insofar as it does not conflict with local requirements.

After revisions to this standard have been issued, they may be applied to tanks that are to be completed after the date of issue. The tank nameplate shall state the date of the edition of the standard and any revision to that edition to which the tank has been designed and constructed.

Each edition, revision, or addenda to this API standard may be used beginning with the date of issuance shown on the cover page for that edition, revision, or addenda. Each edition, revision, or addenda to this API standard becomes effective six months after the date of issuance for equipment that is certified as being rerated, reconstructed, relocated, repaired, modified (altered), inspected, and tested per this standard. During the six-month time between the date of issuance of the edition, revision, or addenda and the effective date, the purchaser and manufacturer shall specify to which edition, revision, or addenda the equipment is to be rerated, reconstructed, relocated, repaired, modified (altered), inspected, and tested.

API publications may be used by anyone desiring to do so. Every effort has been made by the Institute to assure the accuracy and reliability of the data contained in them; however, the Institute makes no representation, warranty, or guarantee in connection with this publication and hereby expressly disclaims any liability or responsibility for loss or damage resulting from its use or for the violation of any federal, state, or municipal regulation with which this publication may conflict.

The purchaser shall specify whether tanks supplied to this standard will have SI dimensions and comply with applicable ISO standards, or have U.S. Customary dimensions and comply with applicable U.S. standards. Where conflicts arise between SI and U.S. Customary units, the U.S. Customary units will govern.

Suggested revisions are invited and should be submitted to the American Petroleum Institute, 1220 L Street, N.W., Washington, D.C. 20005, standards@api.org.

00

## **IMPORTANT INFORMATION CONCERNING USE OF ASBESTOS OR ALTERNATIVE MATERIALS**

Asbestos is specified or referenced for certain components of the equipment described in some API standards. It has been of extreme usefulness in minimizing fire hazards associated with petroleum processing. It has also been a universal sealing material, compatible with most refining fluid services.

Certain serious adverse health effects are associated with asbestos, among them the serious and often fatal diseases of lung cancer, asbestosis, and mesothelioma (a cancer of the chest and abdominal linings). The degree of exposure to asbestos varies with the product and the work practices involved.

Consult the most recent edition of the Occupational Safety and Health Administration (OSHA), U.S. Department of Labor, Occupational Safety and Health Standard for Asbestos, Tremolite, Anthophyllite, and Actinolite, 29 *Code of Federal Regulations* Section 1910.1001; the U.S. Environmental Protection Agency, National Emission Standard for Asbestos, 40 *Code of Federal Regulations* Sections 61.140 through 61.156; and the U.S. Environmental Protection Agency (EPA) rule on labeling requirements and phased banning of asbestos products (Sections 763.160-179).

There are currently in use and under development a number of substitute materials to replace asbestos in certain applications. Manufacturers and users are encouraged to develop and use effective substitute materials that can meet the specifications for, and operating requirements of, the equipment to which they would apply.

SAFETY AND HEALTH INFORMATION WITH RESPECT TO PARTICULAR PRODUCTS OR MATERIALS CAN BE OBTAINED FROM THE EMPLOYER, THE MANUFACTURER OR SUPPLIER OF THAT PRODUCT OR MATERIAL, OR THE MATERIAL SAFETY DATA SHEET.

# CONTENTS

		Page
1	SCOPE .....	1-1
	1.1 General .....	1-1
	1.2 Limitations .....	1-2
	1.3 Compliance .....	1-2
	1.4 Referenced Publications .....	1-3
2	MATERIALS .....	2-1
	2.1 General .....	2-1
	2.2 Plates .....	2-1
	2.3 Sheets .....	2-5
	2.4 Structural Shapes .....	2-5
	2.5 Piping and Forgings .....	2-9
	2.6 Flanges .....	2-10
	2.7 Bolting .....	2-10
	2.8 Welding Electrodes .....	2-10
3	DESIGN .....	3-1
	3.1 Joints .....	3-1
	3.2 Design Considerations .....	3-4
	3.3 Special Considerations .....	3-5
	3.4 Bottom Plates .....	3-5
	3.5 Annular Bottom Plates .....	3-5
	3.6 Shell Design .....	3-6
	3.7 Shell Openings .....	3-10
	3.8 Shell Attachments and Tank Appurtenances .....	3-32
	3.9 Top and Intermediate Wind Girders .....	3-38
	3.10 Roofs .....	3-43
	3.11 Wind Load on Tanks (Overturning Stability) .....	3-51
4	FABRICATION .....	4-1
	4.1 General .....	4-1
	4.2 Shop Inspection .....	4-1
5	ERECTION .....	5-1
	5.1 General .....	5-1
	5.2 Details of Welding .....	5-1
	5.3 Inspection, Testing, and Repairs .....	5-3
	5.4 Repairs to Welds .....	5-4
	5.5 Dimensional Tolerances .....	5-5
6	METHODS OF INSPECTING JOINTS .....	6-1
	6.1 Radiographic Method .....	6-1
	6.2 Magnetic Particle Examination .....	6-3
	6.3 Ultrasonic Examination .....	6-4
	6.4 Liquid Penetrant Examination .....	6-4
	6.5 Visual Examination .....	6-4
7	WELDING PROCEDURE AND WELDER QUALIFICATIONS .....	7-1
	7.1 Definitions .....	7-1
	7.2 Qualification of Welding Procedures .....	7-1
	7.3 Qualification of Welders .....	7-2
	7.4 Identification of Welded Joints .....	7-2

	Page	
8 MARKING .....	8-1	
8.1 Nameplates .....	8-1	00
8.2 Division of Responsibility .....	8-2	
8.3 Certification .....	8-2	
APPENDIX A OPTIONAL DESIGN BASIS FOR SMALL TANKS .....	A-1	00
APPENDIX B RECOMMENDATIONS FOR DESIGN AND CONSTRUCTION OF FOUNDATIONS FOR ABOVEGROUND OIL STORAGE TANKS .....	B-1	
APPENDIX C EXTERNAL FLOATING ROOFS .....	C-1	
APPENDIX D TECHNICAL INQUIRIES .....	D-1	
APPENDIX E SEISMIC DESIGN OF STORAGE TANKS .....	E-1	01
APPENDIX F DESIGN OF TANKS FOR SMALL INTERNAL PRESSURES .....	F-1	
APPENDIX G STRUCTURALLY SUPPORTED ALUMINUM DOME ROOFS .....	G-1	00
APPENDIX H INTERNAL FLOATING ROOFS .....	H-1	
APPENDIX I UNDERTANK LEAK DETECTION AND SUBGRADE PROTECTION .....	I-1	
APPENDIX J SHOP-ASSEMBLED STORAGE TANKS .....	J-1	
APPENDIX K SAMPLE APPLICATION OF THE VARIABLE-DESIGN-POINT METHOD TO DETERMINE SHELL-PLATE THICKNESS .....	K-1	
APPENDIX L API STANDARD 650 STORAGE TANK DATA SHEETS .....	L-1	00
APPENDIX M REQUIREMENTS FOR TANKS OPERATING AT ELEVATED TEMPERATURES .....	M-1	01
APPENDIX N USE OF NEW MATERIALS THAT ARE NOT IDENTIFIED .....	N-1	
APPENDIX O RECOMMENDATIONS FOR UNDER-BOTTOM CONNECTIONS .....	O-1	
APPENDIX P ALLOWABLE EXTERNAL LOADS ON TANK SHELL OPENINGS .....	P-1	01
APPENDIX S AUSTENITIC STAINLESS STEEL STORAGE TANKS .....	S-1	00
APPENDIX T NDE REQUIREMENTS SUMMARY .....	T-1	01
APPENDIX TI TECHNICAL INQUIRY RESPONSES .....	TI-1	

Figures

2-1 Minimum Permissible Design Metal Temperature for Materials Used in Tank Shells Without Impact Testing .....	2-2	
2-2 Isothermal Lines of Lowest One-Day Mean Temperatures .....	2-8	
2-3 Governing Thickness for Impact Test Determination of Shell Nozzle and Manhole Materials .....	2-11	
3-1 Typical Vertical Shell Joints .....	3-2	
3-2 Typical Horizontal Shell Joints .....	3-2	
3-3A Typical Roof and Bottom Joints .....	3-3	
3-3B Method for Preparing Lap-Welded Bottom Plates Under Tank Shell .....	3-3	
3-3C Detail of Double Fillet-Groove Weld for Annular Bottom Plates with a Nominal Thickness Greater Than 13 mm (1/2 in.) .....	3-4	
3-4A Shell Manhole .....	3-14	
3-4B Details of Shell Manholes and Nozzles .....	3-15	
3-5 Shell Nozzles .....	3-16	01
3-6 Minimum Spacing of Welds and Extent of Related Radiographic Examination .....	3-22	
3-7 Shell Nozzle Flanges .....	3-24	

	Page		
3-8	Area Coefficient for Determining Minimum Reinforcement of Flush-Type Cleanout Fittings . . . . .	3-24	
3-9	Flush-Type Cleanout Fittings . . . . .	3-27	00
3-10	Flush-Type Cleanout-Fitting Supports . . . . .	3-28	01
3-11	Flush-Type Shell Connection . . . . .	3-30	
3-12	Rotation of Shell Connection . . . . .	3-33	
3-13	Roof Manholes . . . . .	3-34	00
3-14	Rectangular Roof Openings with Flanged Covers . . . . .	3-36	
3-15	Rectangular Roof Openings with Hinged Cover . . . . .	3-37	
3-16	Flanged Roof Nozzles . . . . .	3-38	
3-17	Threaded Roof Nozzles . . . . .	3-40	
3-18	Drawoff Sump . . . . .	3-41	
3-19	Scaffold Cable Support . . . . .	3-43	
3-20	Typical Stiffening-Ring Sections for Tank Shells . . . . .	3-44	
3-21	Stairway Opening Through Stiffening Ring . . . . .	3-46	
3-22	Minimum Weld Spacing Requirements for Openings in Shells According to Section 3.7.3 . . . . .	3-49	00
6-1	Radiographic Requirements for Tank Shells . . . . .	6-2	
8-1	Manufacturer's Nameplate . . . . .	8-1	
8-2	Manufacturer's Certification Letter . . . . .	8-2	
A-1	Flush-Type Bolted Door Sheet . . . . .	A-11	
A-2	Supports for Flush-Type Bolted Door Sheet . . . . .	A-13	
A-3	Raised-Type Bolted Door Sheet . . . . .	A-15	
B-1	Example of Foundation With Concrete Ringwall . . . . .	B-3	
B-2	Example of Foundation With Crushed Stone Ringwall . . . . .	B-4	
E-1	Seismic Zones . . . . .	E-2	
E-2	Effective Masses . . . . .	E-5	
E-3	Centroids of Seismic Forces . . . . .	E-5	
E-4	Factor $k$ . . . . .	E-5	
E-5	Compressive Force $b$ . . . . .	E-6	
F-1	Appendix F Decision Tree . . . . .	F-2	
F-2	Permissible Details of Compression Rings . . . . .	F-3	
G-1	Data Sheet for a Structurally Supported Aluminum Dome Added to an Existing Tank . . . . .	G-2	
G-2	Typical Roof Nozzle . . . . .	G-6	
I-1	Concrete Ringwall with Undertank Leak Detection at the Tank Perimeter . . . . .	I-1	
I-2	Crushed Stone Ringwall with Undertank Leak Detection at the Tank Perimeter . . . . .	I-2	
I-3	Earthen Foundation with Undertank Leak Detection at the Tank Perimeter . . . . .	I-2	
I-4	Double Steel Bottom with Leak Detection at the Tank Perimeter . . . . .	I-3	
I-5	Double Steel Bottom with Leak Detection at the Tank Perimeter . . . . .	I-3	
I-6	Reinforced Concrete Slab with Leak Detection at the Perimeter . . . . .	I-4	
I-7	Reinforced Concrete Slab with Radial Grooves for Leak Detection . . . . .	I-4	
I-8	Typical Drawoff Sump . . . . .	I-5	
I-9	Center Sump for Downward-Sloped Bottom . . . . .	I-5	
I-10	Typical Leak Detection Wells . . . . .	I-6	
I-11	Tanks Supported by Grillage Members . . . . .	I-8	
O-1	Example of Under-Bottom Connection with Concrete Ringwall Foundation . . . . .	O-2	
O-2	Example of Under-Bottom Connection with Concrete Ringwall Foundation and Improved Tank Bottom and Shell Support . . . . .	O-3	
O-3	Example of Under-Bottom Connection with Earth-Type Foundation . . . . .	O-4	
P-1	Nomenclature for Piping Loads and Deformation . . . . .	P-3	
P-2A	Stiffness Coefficient for Radial Load: Reinforcement on Shell . . . . .	P-4	
P-2B	Stiffness Coefficient for Longitudinal Moment: Reinforcement on Shell . . . . .	P-4	

	Page
P-2C Stiffness Coefficient for Circumferential Moment: Reinforcement on Shell . . .	P-5
P-2D Stiffness Coefficient for Radial Load: Reinforcement on Shell . . . . .	P-5
P-2E Stiffness Coefficient for Longitudinal Moment: Reinforcement on Shell . . . . .	P-6
P-2F Stiffness Coefficient for Circumferential Moment: Reinforcement on Shell . . .	P-6
P-2G Stiffness Coefficient for Radial Load: Reinforcement in Nozzle Neck Only . . .	P-7
P-2H Stiffness Coefficient for Longitudinal Moment: Reinforcement in Nozzle Neck Only . . . . .	P-7
P-2I Stiffness Coefficient for Circumferential Moment: Reinforcement in Nozzle Neck Only . . . . .	P-8
P-2J Stiffness Coefficient for Radial Load: Reinforcement in Nozzle Neck Only . . .	P-8
P-2K Stiffness Coefficient for Longitudinal Moment: Reinforcement in Nozzle Neck Only . . . . .	P-9
P-2L Stiffness Coefficient for Circumferential Moment: Reinforcement in Nozzle Neck Only . . . . .	P-9
P-3A Construction of Nomogram for $b_1, b_2, c_1, c_2$ Boundary . . . . .	P-11
P-3B Construction of Nomogram for $b_1, c_3$ Boundary . . . . .	P-11
P-4A Obtaining Coefficients $Y_F$ and $Y_L$ . . . . .	P-12
P-4B Obtaining Coefficient $Y_C$ . . . . .	P-13
P-5A Determination of Allowable Loads from Nomogram: $F_R$ and $M_L$ . . . . .	P-14
P-5B Determination of Allowable Loads from Nomogram: $F_R$ and $M_C$ . . . . .	P-14
P-6 Low-Type Nozzle with Reinforcement in Nozzle Neck Only . . . . .	P-15
P-7 Allowable-Load Nomograms for Sample Problem . . . . .	P-17

Tables

1-1 Status of Appendixes to API Standard 650 . . . . .	1-2	
2-1 Maximum Permissible Alloy Content . . . . .	2-3	
2-2 Acceptable Grades of Plate Material Produced to National Standards . . . . .	2-4	
2-3a Material Groups, SI Units . . . . .	2-6	01
2-3b Material Groups, US Customary Units . . . . .	2-7	
2-4 Minimum Impact Test Requirements for Plates . . . . .	2-9	
3-1 Annular Bottom-Plate Thicknesses . . . . .	3-6	01 00
3-2 Permissible Plate Materials and Allowable Stresses . . . . .	3-8	
3-3 Thickness of Shell Manhole Cover Plate and Bolting Flange . . . . .	3-12	
3-4 Dimensions for Shell Manhole Neck Thickness . . . . .	3-12	
3-5 Dimensions for Bolt Circle Diameter $D_b$ and Cover Plate Diameter $D_c$ for Shell Manholes . . . . .	3-13	
3-6 Dimensions for Shell Nozzles . . . . .	3-18	01
3-7 Dimensions for Shell Nozzles: Pipe, Plate, and Welding Schedules . . . . .	3-19	
3-8 Dimensions for Shell Nozzle Flanges . . . . .	3-20	
3-9 Dimensions for Flush-Type Cleanout Fittings . . . . .	3-21	
3-10 Minimum Thickness of Cover Plate, Bolting Flange, and Bottom Reinforcing Plate for Flush-Type Cleanout Fittings . . . . .	3-23	
3-11 Thicknesses and Heights of Shell Reinforcing Plates for Flush-Type Cleanout Fittings . . . . .	3-26	
3-12 Dimensions for Flush-Type Shell Connections . . . . .	3-29	
3-13 Dimensions for Roof Manholes . . . . .	3-35	
3-14 Dimensions for Flanged Roof Nozzles . . . . .	3-35	
3-15 Dimensions for Threaded Roof Nozzles . . . . .	3-35	
3-16 Dimensions for Drawoff Sumps . . . . .	3-39	
3-17 Requirements for Platforms and Walkways . . . . .	3-40	
3-18 Requirements for Stairways . . . . .	3-40	
3-19 Rise, Run, and Angle Relationships for Stairways . . . . .	3-42	
3-20 Section Moduli of Stiffening-Ring Sections on Tank Shells . . . . .	3-45	

A-1a	Typical Sizes and Corresponding Nominal Capacities for Tanks with 1800 mm Courses . . . . .	A-2
A-1b	Typical Sizes and Corresponding Nominal Capacities for Tanks with 72-in. Courses . . . . .	A-3
A-2a	Shell-Plate Thicknesses for Typical Sizes of Tanks with 1800 mm Courses . . . . .	A-4
A-2b	Shell-Plate Thicknesses for Typical Sizes of Tanks with 72-in. Courses . . . . .	A-5
A-3a	Typical Sizes and Corresponding Nominal Capacities for Tanks with 2400 mm Courses . . . . .	A-6
A-3b	Typical Sizes and Corresponding Nominal Capacities for Tanks with 96-in. Courses . . . . .	A-7
A-4a	Shell-Plate Thicknesses for Typical Sizes of Tanks with 2400 mm Courses . . . . .	A-8
A-4b	Shell-Plate Thicknesses for Typical Sizes of Tanks with 96-in. Courses . . . . .	A-9
A-5	Flush-Type Bolted Door Sheets . . . . .	A-12
A-6	Raised-Type Bolted Door Sheets . . . . .	A-14
E-1	Seismic Zone Tabulation for Areas Outside the United States . . . . .	E-4
E-2	Seismic Zone Factor . . . . .	E-4
E-3	Site Coefficients . . . . .	E-6
F-1	Design Stresses for Anchors of Tanks With Design Pressures up to 18 kPa (2 <sup>1</sup> / <sub>2</sub> lbf/in. <sup>2</sup> ) Gauge . . . . .	F-5
G-1	Bolts and Fasteners . . . . .	G-3
J-1	Maximum Roof Depths for Shop-Assembled Dome-Roof Tanks . . . . .	J-2
K-1	Shell-Plate Thicknesses Based on the Variable-Design-Point Method Using 2400 mm (96 in.) Courses and an Allowable Stress of 159 MPa (23,000 lbf/in. <sup>2</sup> ) for the Test Condition . . . . .	K-9
K-2	Shell-Plate Thicknesses Based on the Variable-Design-Point Method Using 2400 mm (96 in.) Courses and an Allowable Stress of 208 MPa (30,000 lbf/in. <sup>2</sup> ) for the Test Condition . . . . .	K-10
K-3	Shell-Plate Thicknesses Based on the Variable-Design-Point Method Using 2400 mm (96 in.) Courses and an Allowable Stress of 236 MPa (34,300 lbf/in. <sup>2</sup> ) for the Test Condition . . . . .	K-11
L-1	Index of Decisions or Actions Which May be Required of the Purchaser . . . . .	L-7
M-1	Yield Strength Reduction Factors . . . . .	M-2
M-2	Modulus of Elasticity at the Maximum Operating Temperature . . . . .	M-4
O-1	Dimensions of Under-Bottom Connections . . . . .	O-1
P-1	Modulus of Elasticity and Thermal Expansion Coefficient at the Design Temperature . . . . .	P-2
S-1a	ASTM Materials for Stainless Steel Components (SI units) . . . . .	S-1
S-1b	ASTM Materials for Stainless Steel Components (US Customary units) . . . . .	S-2
S-2	Allowable Stresses for Tank Shells . . . . .	S-5
S-3	Allowable Stresses for Plate Ring Flanges . . . . .	S-5
S-4	Joint Efficiencies . . . . .	S-5
S-5	Yield Strength Values in MPa (psi) . . . . .	S-6
S-6	Modulus of Elasticity at the Maximum Operating Temperature . . . . .	S-6



# Welded Steel Tanks for Oil Storage

## 1 Scope

### 1.1 GENERAL

**1.1.1** This standard covers material, design, fabrication, erection, and testing requirements for vertical, cylindrical, aboveground, closed- and open-top, welded steel storage tanks in various sizes and capacities for internal pressures approximating atmospheric pressure (internal pressures not exceeding the weight of the roof plates), but a higher internal pressure is permitted when additional requirements are met (see 1.1.10). This standard applies only to tanks whose entire bottom is uniformly supported and to tanks in nonrefrigerated service that have a maximum operating temperature of 90°C (200°F) (see 1.1.17).

**1.1.2** This standard is designed to provide the petroleum industry with tanks of adequate safety and reasonable economy for use in the storage of petroleum, petroleum products, and other liquid products commonly handled and stored by the various branches of the industry. This standard does not present or establish a fixed series of allowable tank sizes; instead, it is intended to permit the purchaser to select whatever size tank may best meet his needs. This standard is intended to help purchasers and manufacturers in ordering, fabricating, and erecting tanks; it is not intended to prohibit purchasers and manufacturers from purchasing or fabricating tanks that meet specifications other than those contained in this standard.

Note: A bullet (•) at the beginning of a paragraph indicates that there is an expressed decision or action required of the purchaser. The purchaser's responsibility is not limited to these decisions or actions alone. When such decisions and actions are taken, they are to be specified in documents such as requisitions, change orders, data sheets, and drawings.

**1.1.3** The purchaser will specify whether tanks constructed to this standard shall have SI dimensions and comply with applicable SI unit standards or have US Customary dimensions and comply with applicable US Customary unit standards.

**1.1.4** The appendices of this standard provide a number of design options requiring decisions by the purchaser, standard requirements, recommendations, and information that supplements the basic standard. An appendix becomes a requirement only when the purchaser specifies an option covered by that appendix. See Table 1-1 for the status of each appendix.

**1.1.5** Appendix A provides alternative simplified design requirements for tanks where the stressed components, such as shell plates and reinforcing plates, are limited to a maximum nominal thickness of 12.5 mm (1/2 in.), including any

corrosion allowance, and to the minimum design metal temperatures stated in the appendix.

**1.1.6** Appendix B provides recommendations for the design and construction of foundations for flat-bottom oil storage tanks.

**1.1.7** Appendix C provides minimum requirements for pan-type, pontoon-type, and double-deck-type external floating roofs.

**1.1.8** Appendix D provides requirements for submission of technical inquiries on this standard.

• **1.1.9** Appendix E provides minimum requirements for tanks subject to seismic loading. An alternative or supplemental design may be mutually agreed upon by the manufacturer and purchaser.

**1.1.10** Appendix F provides requirements for the design of tanks subject to a small internal pressure.

**1.1.11** Appendix G provides requirements for an optional aluminum dome roof.

**1.1.12** Appendix H provides minimum requirements that apply to an internal floating roof in a tank with a fixed roof at the top of the tank shell.

• **1.1.13** Appendix I provides acceptable construction details that may be specified by the purchaser for design and construction of tank and foundation systems that provide leak detection and subgrade protection in the event of tank bottom leakage, and provides for tanks supported by grillage.

**1.1.14** Appendix J provides requirements covering the complete shop assembly of tanks that do not exceed 6 m (20 ft) in diameter.

**1.1.15** Appendix K provides a sample application of the variable-design-point method to determine shell-plate thicknesses.

**1.1.16** Appendix L provides data sheets listing required information to be used by the purchaser in ordering a storage tank and by the manufacturer upon completion of construction of the tank.

**1.1.17** Appendix M provides requirements for tanks specified and designed to operate at temperatures exceeding 90°C (200°F) but not exceeding 260°C (500°F).

**1.1.18** Appendix N provides requirements for the use of new or unused plate and pipe materials that are not completely identified as complying with any listed specification for use in accordance with this standard.

00

98

98

Table 1-1—Status of Appendixes to API Standard 650

Appendix	Title	Status
	A Optional design basis for small tanks	Purchaser's Option
	B Recommendations for design and construction of foundations for aboveground oil storage tanks	Recommendations
98	C External floating roofs	Purchaser's Option
	D Technical inquiries	Required Procedures
	● E Seismic design of storage tanks	Purchaser's option
	F Design of tanks for small internal pressures	Requirements
98	G Structurally supported aluminum dome roofs	Purchaser's Option
	H Internal floating roofs	Purchaser's Option
	● I Undertank leak detection and subgrade protection	Purchaser's option
	J Shop-assembled storage tanks	Requirements
	K Sample application of the variable-design-point method to determine shell-plate thickness	Information
98	L API Standard 650 storage tank data sheets	Requirements
	M Requirements for tanks operating at elevated temperatures	Requirements
	N Use of new materials that are not identified	Requirements
	● O Recommendation for under-bottom connections	Purchaser's option
	● P Allowable external load on tank shell openings	Purchaser's option
	S Austenitic stainless steel storage tanks	Requirements
98	Definitions:	
	Mandatory:	Required sections of the standard become mandatory if the standard has been adopted by a Legal Jurisdiction or if the purchaser and the manufacturer choose to make reference to this standard on the nameplate or in the manufacturer's certification.
	Requirement:	The outlined design criteria must be used unless the purchaser and manufacturer agree upon a more stringent alternative design.
	Recommendation:	The outlined criteria provides a good acceptable design and may be used at the option of the purchaser and manufacturer.
98	● Purchaser's Option:	When the purchaser specifies an option covered by an appendix, the appendix then becomes a requirement.

● 1.1.19 Appendix O provides recommendations for the design and construction of under-bottom connections for storage tanks.

● 1.1.20 Appendix P provides minimum recommendations for design of shell openings that conform to Table 3-6 that are subject to external piping loads. An alternative or supplemental design may be agreed upon by the purchaser or manufacturer.

1.1.21 Appendix S provides requirements for stainless steel tanks.

1.1.22 Appendix T summarizes the requirements for inspection by method of examination and the reference sections within the standard. The acceptance standards, examiner qualifications, and procedure requirements are also provided. This appendix is not intended to be used alone to determine the inspection requirements within this standard. The specific requirements listed within each applicable section shall be followed in all cases.

## 1.2 LIMITATIONS

The rules of this standard are not applicable beyond the following limits of piping connected internally or externally to the roof, shell, or bottom of tanks constructed according to this standard:

- The face of the first flange in bolted flanged connections, unless covers or blinds are provided as permitted in this standard.
- The first sealing surface for proprietary connections or fittings.
- The first threaded joint on the pipe in a threaded connection to the tank wall.
- The first circumferential joint in welding-end pipe connections if not welded to a flange.

## ● 1.3 COMPLIANCE

The manufacturer is responsible for complying with all provisions of this standard. Inspection by the purchaser's inspector (the term inspector as used herein) does not negate the manufacturer's obligation to provide quality control and inspection necessary to ensure such compliance.

## 1.4 REFERENCED PUBLICATIONS

The following standards, codes, specifications, and publications are cited in this standard. The most recent edition shall be used unless otherwise specified.

### API

- Spec 5L *Specification for Line Pipe*  
 Std 620 *Design and Construction of Large, Welded, Low-Pressure Storage Tanks*  
 RP 651 *Cathodic Protection of Aboveground Petroleum Storage Tanks*  
 RP 652 *Lining of Aboveground Petroleum Storage Tank Bottoms*  
 Std 2000 *Venting Atmospheric and Low-Pressure Storage Tanks (Nonrefrigerated and Refrigerated)*  
 RP 2003 *Protection Against Ignitions Arising Out of Static, Lightning, and Stray Currents*  
 Publ 2026 *Safe Access/Egress Involving Floating Roofs of Storage Tanks in Petroleum Service*  
 RP 2350 *Overfill Protection for Storage Tanks in Petroleum Facilities*

### AA<sup>1</sup>

- Aluminum Design Manual*  
*Aluminum Standards and Data*  
*Specifications for Aluminum Sheet Metal Work in Building Construction*

### ACI<sup>2</sup>

- 318 *Building Code Requirements for Reinforced Concrete (ANSI/ACI 318)*  
 350 *Environmental Engineering Concrete Structures*

### AISC<sup>3</sup>

- Manual of Steel Construction, Allowable Stress Design*

### AISI<sup>4</sup>

- E-1 *Steel Plate Engineering Data Series: Useful Information—Design of Plate Structures, Volume II*

### ASCE<sup>5</sup>

- ASCE Std. 7-93 *Minimum Design Loads for Buildings and other Structures*

<sup>1</sup>The Aluminum Association Inc., 900 19th Street, N.W., Washington, D.C. 20006, www.aluminum.org.

<sup>2</sup>American Concrete Institute, P.O. Box 19150, Detroit, Michigan 48219-0150, www.aci-int.org.

<sup>3</sup>American Institute of Steel Construction, One East Wacker Drive, Suite 3100, Chicago, Illinois 60601-2001, www.aisc.org.

<sup>4</sup>American Iron and Steel Institute, 1101 17th Street, N.W., Suite 1300, Washington, D.C. 20036-4700, www.steel.org.

<sup>5</sup>American Society of Civil Engineers, 1801 Alexander Bell Drive, Reston, VA 20191-4400, www.asce.org.

### ASME<sup>6</sup>

- B1.20.1 *Pipe Threads, General Purpose (Inch) (ANSI/ASME B1.20.1)*  
 B16.1 *Cast Iron Pipe Flanges and Flanged Fittings (ANSI/ASME B16.1)*  
 B16.5 *Pipe Flanges and Flanged Fittings (ANSI/ASME B16.5)*  
 B16.47 *Large Diameter Steel Flanges: NPS 26 Through NPS 60 (ANSI/ASME B16.47)*  
 B96.1 *Welded Aluminum-Alloy Storage Tanks (ANSI/ASME B96.1)*  
*Boiler & Pressure Vessel Code, Section V, “Nondestructive Examination”; Section VIII, “Pressure Vessels,” Division 1; and Section IX, “Welding and Brazing Qualifications”*

### ASNT<sup>7</sup>

- RP SNT-TC-1A *Personnel Qualification and Certification in Nondestructive Testing*

### ASTM<sup>8</sup>

- A 6M/A 6 *General Requirements for Rolled Steel Plates, Shapes, Sheet Piling, and Bars for Structural Use*  
 A 20M/A 20 *General Requirements for Steel Plates for Pressure Vessels*  
 A 27M/A 27 *Steel Castings, Carbon, for General Application*  
 A 36M/A 36 *Structural Steel*  
 A 53 *Pipe, Steel, Black and Hot-Dipped, Zinc-Coated Welded and Seamless*  
 A 105M/A 105 *Forgings, Carbon Steel, for Piping Components*  
 A 106 *Seamless Carbon Steel Pipe for High-Temperature Service*  
 A 131M/A 131 *Structural Steel for Ships*  
 A 181M/A 181 *Forgings, Carbon Steel, for General-Purpose Piping*  
 A 182M/A 182 *Forged or Rolled Alloy-Steel Pipe Flanges, Forged Fittings, and Valves and Parts for High-Temperature Service*

<sup>6</sup>ASME International, 3 Park Avenue, New York, New York 10016-5990, www.asme.org.

<sup>7</sup>American Society for Nondestructive Testing, 1711 Arlingate Lane, Columbus, Ohio 43228-0518, www.asnt.org.

<sup>8</sup>ASTM, 100 Barr Harbor Drive, West Conshohocken, Pennsylvania 19428-2959, www.astm.org.

- A 193M/A 193 *Alloy-Steel and Stainless Steel Bolting Materials for High-Temperature Service*
- A 194M/A 194 *Carbon and Alloy Steel Nuts for Bolts for High-Pressure and High-Temperature Service*
- A 213M/A 213 *Seamless Ferritic and Austenitic Alloy-Steel Boiler, Superheater, and Heat-Exchanger Tubes*
- A 216M/A 216 *Standard Specifications for Steel Castings for High-Temperature Service*
- A 234M/A 234 *Piping Fittings of Wrought Carbon Steel and Alloy Steel for Moderate and High-Temperature Service*
- A 240M/A 240 *Heat-Resisting Chromium and Chromium-Nickel Stainless Steel Plate, Sheet, and Strip for Pressure Vessels*
- A 276 *Stainless Steel Bars and Shapes*
- A 283M/A 283 *Low and Intermediate Tensile Strength Carbon Steel Plates*
- A 285M/A 285 *Pressure Vessel Plates, Carbon Steel, Low- and Intermediate-Tensile Strength*
- A 307 *Carbon Steel Bolts and Studs, 60,000 psi Tensile Strength*
- A 312M/A 312 *Seamless and Welded Austenitic Stainless Steel Pipes*
- A 320M/A 320 *Alloy Steel Bolting Materials for Low-Temperature Service*
- A 333M/A 333 *Seamless and Welded Steel Pipe for Low-Temperature Service*
- A 334M/A 334 *Seamless and Welded Carbon and Alloy-Steel Tubes for Low-Temperature Service*
- A 350M/A 350 *Forgings, Carbon and Low-Alloy Steel, Requiring Notch Toughness Testing for Piping Components*
- A 351M/A 351 *Castings, Austenitic, Austenitic-Ferritic (Duplex), for Pressure-Containing Parts*
- A 358M/A 358 *Electric-Fusion-Welded Austenitic Chromium-Nickel Alloy Steel Pipe for High-Temperature Service*
- A 370 *Test Methods and Definitions for Mechanical Testing of Steel Products*
- A 380 *Cleaning, Descaling, and Passivation of Stainless Steel Parts, Equipment, and Systems*
- A 403M/A 403 *Wrought Austenitic Stainless Steel Piping Fittings*
- A 420M/A 420 *Piping Fittings of Wrought Carbon Steel and Alloy Steel for Low-Temperature Service*
- A 479M/A 479 *Stainless Steel Bars and Shapes for Use in Boilers and Other Pressure Vessels*
- A 480M/A 480 *Flat-Rolled Stainless and Heat-Resisting Steel Plate, Sheet, and Strip* | 98
- A 516M/A 516 *Pressure Vessel Plates, Carbon Steel, for Moderate- and Lower-Temperature Service*
- A 524 *Seamless Carbon Steel Pipe for Atmospheric and Lower Temperatures*
- A 537M/A 537 *Pressure Vessel Plates, Heat-Treated, Carbon-Manganese-Silicon Steel*
- A 570M/A 570 *Hot-Rolled Carbon Steel Sheet and Strip, Structural Quality*
- A 573M/A 573 *Structural Carbon Steel Plates of Improved Toughness*
- A 633M/A 633 *Normalized High-Strength Low-Alloy Structural Steel*
- A 662M/A 662 *Pressure Vessel Plates, Carbon-Manganese, for Moderate and Lower Temperature Service*
- A 671 *Electric-Fusion-Welded Steel Pipe for Atmospheric and Lower Temperatures*
- A 678M/A 678 *Quenched and Tempered Carbon-Steel and High-Strength Low-Alloy Steel Plates for Structural Applications*
- A 737M/A 737 *Pressure Vessel Plates, High-Strength, Low-Alloy Steel*
- A 841M/A 841 *Standard Specification for Steel Plates for Pressure Vessels, Produced by the Thermo-Mechanical Control Process (TMCP)*
- A 924M/A 924 *General Requirements for Steel Sheet, Metallic-Coated by the Hot-Dip Process*
- A 992M/A 992 *Steel for Structural Shapes for Use in Building Framing* | 01
- C 273 *Method for Shear Test in Flatwise Plane of Flat Sandwich Constructions or Sandwich Cores*
- C 509 *Cellular Elastomeric Preformed Gasket and Sealing Material*
- D 1621 *Test Method for Compressive Properties of Rigid Cellular Plastics*
- D 1622 *Test Method for Apparent Density of Rigid Cellular Plastics (ANSI/ASTM D1622)*
- D 2341 *Rigid Urethane Foam*

D 2856	<i>Test Method for Open Cell Content of Rigid Cellular Plastics by the Air Pycnometer</i>	Supplement to National Building Code of Canada
D 3453	<i>Flexible Cellular Materials—Urethane for Furniture and Automotive Cushioning, Bedding, and Similar Applications</i>	Federal Specifications <sup>11</sup>
E 84	<i>Test Method for Surface Burning Characteristics of Building Materials</i>	TT-S-00230C <i>Sealing Compound Elastomeric Type, Single Component for Caulking, Sealing, and Glazing in Buildings and Other Structures</i>
E 96	<i>Test Methods for Water Vapor Transmission of Materials</i>	ZZ-R-765C <i>Rubber, Silicone (General Specification)</i>
AWS <sup>9</sup>		ISO <sup>12</sup>
A5.1	<i>Specification for Carbon Steel Covered Arc-Welding Electrodes</i>	630 <i>Structural Steels</i>
A5.5	<i>Specification for Low-Alloy Steel Covered Arc-Welding Electrodes</i>	NFPA <sup>13</sup>
D1.2	<i>Structural Welding Code—Aluminum</i>	11 <i>Standard for Low-Expansion Foam</i>
CSA <sup>10</sup>		30 <i>Flammable and Combustible Liquids Code</i>
G40.21-M	<i>Structural Quality Steels</i>	

<sup>9</sup>American Welding Society, 550 N.W. LeJeune Road, Miami, Florida 33135, www.aws.org.

<sup>10</sup>Canadian Standards Association, 178 Rexdale Boulevard, Rexdale, Ontario M9W 1R3, www.csa.ca.

<sup>11</sup>Specifications Unit (WFSIS), 7th and D Streets, N.W., Washington, D.C. 20407.

<sup>12</sup>International Organization for Standardization. ISO publications can be obtained from the American National Standards Institute (ANSI) and national standards organizations such as the British Standards Institute (BSI), Japanese Industrial Standards (JIS), and Deutsches Institut fuer Normung [German Institute for Standardization (DIN)], www.iso.ch.

<sup>13</sup>NFPA International, 1 Batterymarch Park, Quincy, MA 02269-9101, www.nfpa.org.



## SECTION 2—MATERIALS

### 2.1 GENERAL

- **2.1.1** Materials used in the construction of tanks shall conform to the specifications listed in this section, subject to the modifications and limitations indicated in this standard. Material produced to specifications other than those listed in this section may be employed, provided that the material is certified to meet all of the requirements of a material specification listed in this standard and the material's use is approved by the purchaser. The manufacturer's proposal shall identify the material specifications to be used.
- **2.1.2** When any new or unused plate and pipe material cannot be completely identified by records that are satisfactory to the purchaser as material conforming to a specification listed in this standard, the material or product may be used in the construction of tanks covered by this standard only if the material passes the tests prescribed in Appendix N.

**2.1.3** When a tank is designed to the requirements of this standard using plate material from Group-I through Group-III A steels, the tank manufacturer responsible for any proposed material substitution to use Group-IV through Group-VI steels must:

- a. Maintain all of the original design criteria for the lower stress Group-I through Group III A steels.
- b. Obtain the prior written approval of the purchaser.
- c. Ensure that all of the design, fabrication, erection and inspection requirements for the material being substituted will meet the lower stress Group-I through Group III A specifications for items including but not limited to:
  - 1. Material properties and production process methods.
  - 2. Allowable stress levels.
  - 3. Notch toughness.
  - 4. Welding procedures and consumables.
  - 5. Thermal stress relief.
  - 6. Temporary and permanent attachment details and procedures.
  - 7. Nondestructive examinations.
- d. Include the pertinent information in the documents provided to the purchaser, including a certification statement that the substituted material fully complies with 2.1.3 in all respects, and provide all other records covered by the work processes applied to the material such as impact testing, weld procedures, nondestructive examinations, and heat treatments.

### 2.2 PLATES

#### 2.2.1 General

**2.2.1.1** Except as otherwise provided for in 2.1, plates shall conform to one of the specifications listed in 2.2.2

through 2.2.5, subject to the modifications and limitations in this standard.

**2.2.1.2** Plate for shells, roofs, and bottoms may be ordered on an edge-thickness basis or on a weight [ $\text{kg/m}^2$  ( $\text{lb/ft}^2$ )] basis, as specified in 2.2.1.2.1 through 2.2.1.2.3.

**2.2.1.2.1** The edge thickness ordered shall not be less than the computed design thickness or the minimum permitted thickness.

**2.2.1.2.2** The weight ordered shall be great enough to provide an edge thickness not less than the computed design thickness or the minimum permitted thickness.

**2.2.1.2.3** Whether an edge-thickness or a weight basis is used, an underrun not more than 0.25 mm (0.01 in.) from the computed design thickness or the minimum permitted thickness is acceptable.

- **2.2.1.3** All plates shall be manufactured by the open-hearth, electric-furnace, or basic oxygen process. Steels produced by the thermo-mechanical control process (TMCP) may be used, provided that the combination of chemical composition and integrated controls of the steel manufacturing is mutually acceptable to the purchaser and the manufacturer, and provided that the specified mechanical properties in the required plate thicknesses are achieved. Copper-bearing steel shall be used if specified by the purchaser.

**2.2.1.4** Shell plates are limited to a maximum thickness of 45 mm (1.75 in.) unless a lesser thickness is stated in this standard or in the plate specification. Plates used as inserts or flanges may be thicker than 45 mm (1.75 in.). Plates thicker than 40 mm (1.5 in.) shall be normalized or quench tempered, killed, made to fine-grain practice, and impact tested.

#### 2.2.2 ASTM Specifications

Plates that conform to the following ASTM specifications are acceptable as long as the plates are within the stated limitations:

- a. ASTM A 36M/A 36 for plates to a maximum thickness of 40 mm (1.5 in.). None of the specifications for the appurtenant materials listed in Table 1 of ASTM A 36M/A 36 are considered acceptable for tanks constructed under this standard unless it is expressly stated in this standard that the specifications are acceptable.
- b. ASTM A 131M/A 131, Grade A, for plates to a maximum thickness of 12.5 mm (0.5 in.); Grade B for plates to a maximum thickness of 25 mm (1 in.); Grade CS for plates to a maximum thickness of 40 mm (1.5 in.) [insert plates and flanges to a maximum thickness of 50 mm (2 in.)]; and Grade EH36 for plates to a maximum thickness of 45 mm

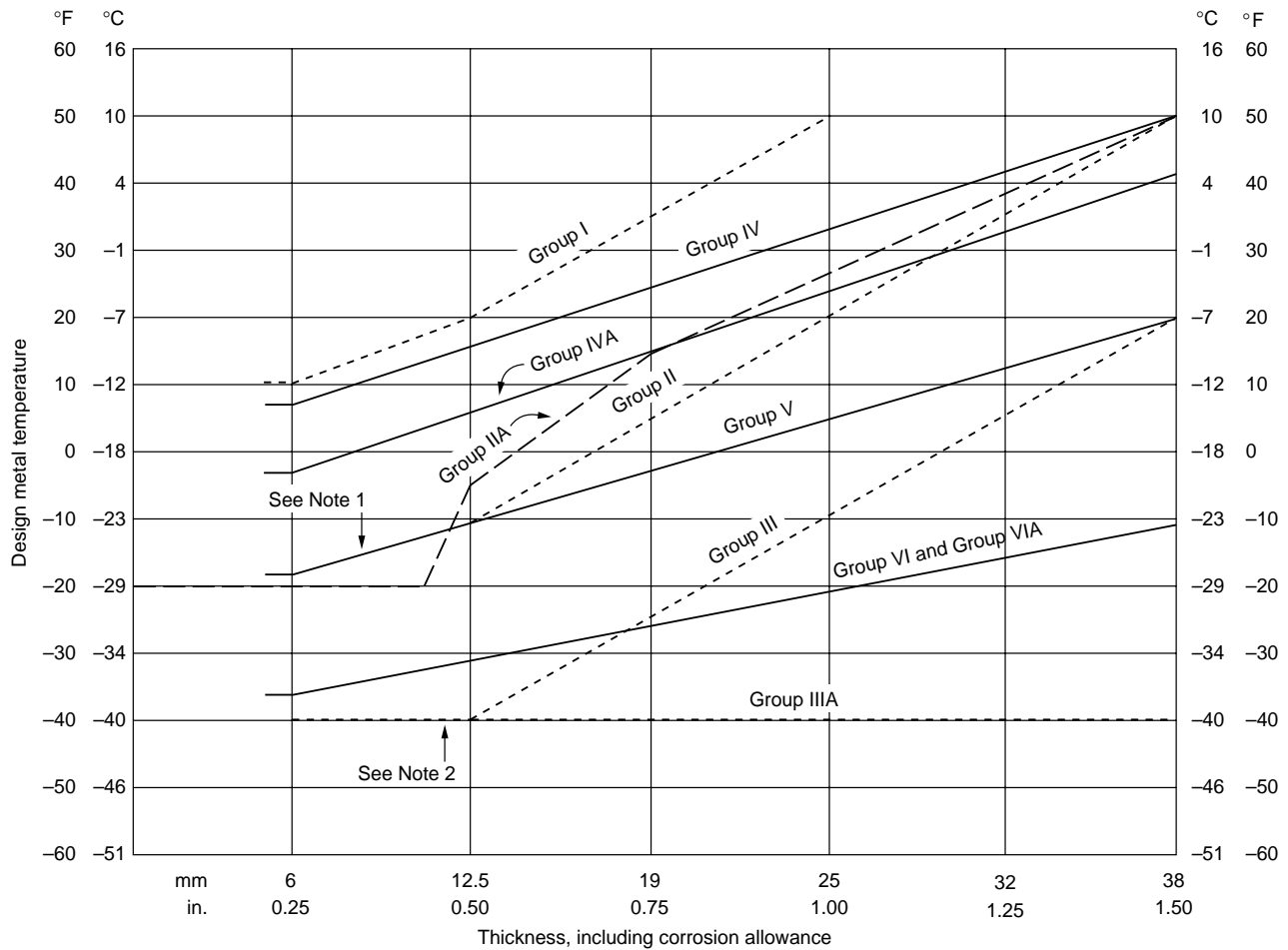

## Notes:

1. The Group II and Group V lines coincide at thicknesses less than 12.5 mm ( $1/2$  in.).
2. The Group III and Group IIIA lines coincide at thicknesses less than 12.5 mm ( $1/2$  in.).
3. The materials in each group are listed in Table 2-3.
4. This figure is not applicable to controlled-rolled plates (see 2.2.7.4).
5. Use the Group IIA and Group VIA curves for pipe and flanges (see 2.5.5.2 and 2.5.5.3).

Figure 2-1—Minimum Permissible Design Metal Temperature for Materials Used in Tank Shells Without Impact Testing

(1.75 in.) [insert plates and flanges to a maximum thickness of 50 mm (2 in.)].

c. ASTM A 283M/A 283, Grade C, for plates to a maximum thickness of 25 mm (1 in.).

d. ASTM A 285M/A 285, Grade C, for plates to a maximum thickness of 25 mm (1 in.).

e. ASTM A 516M Grades 380, 415, 450, 485/A 516, Grades 55, 60, 65, and 70, for plates to a maximum thickness of 40 mm (1.5 in.) [insert plates and flanges to a maximum thickness of 100 mm (4 in.)].

f. ASTM A 537M/A 537, Class 1 and Class 2, for plates to a maximum thickness of 45 mm (1.75 in.) [insert plates to a maximum thickness of 100 mm (4 inches)].

g. ASTM A 573M Grades 400, 450, 485/A 573, Grades 58, 65, and 70, for plates to a maximum thickness of 40 mm (1.5 in.).

h. ASTM A 633M/A 633, Grades C and D, for plates to a maximum thickness of 45 mm (1.75 in.) [insert plates to a maximum thickness of 100 mm (4.0 in.)].

i. ASTM A 662M/A 662, Grades B and C, for plates to a maximum thickness of 40 mm (1.5 in.).

j. ASTM A 678M/A 678, Grade A, for plates to a maximum thickness of 40 mm (1.5 in.) [insert plates to a maximum thickness of 65 mm (2.5 in.)] and Grade B for plates to a maximum thickness of 45 mm (1.75 in.) [insert plates to a maximum thickness of 65 mm (2.5 in.)]. Boron additions are not permitted.

100

k. ASTM A 737M/A 737, Grade B, for plates to a maximum thickness of 40 mm (1.5 in.).

l. ASTM A 841M/A 841 for plates to a maximum thickness of 40 mm (1.5 in.) [insert plates to a maximum thickness of 65 mm (2.5 in.)].

### 2.2.3 CSA Specifications

Plate furnished to CSA G40.21-M in Grades 260W, 300W, and 350W is acceptable within the limitations stated below. (If impact tests are required, Grades 260W, 300W, and 350W are designated as Grades 260WT, 300WT, and 350WT, respectively.) Imperial unit equivalent grades of CSA Specification G40.21 are also acceptable.

- The W grades may be semikilled or fully killed.
- Fully killed steel made to fine-grain practice must be specified when required.
- Elements added for grain refining or strengthening shall be restricted in accordance with Table 2-1.
- Plates shall have tensile strengths that are not more than 140 MPa (20 ksi) above the minimum specified for the grade.
- Grades 260W and 300W are acceptable for plate to a maximum thickness of 25 mm (1 in.) if semikilled and to a maximum thickness of 40 mm (1.5 in.) if fully killed and made to fine-grain practice.
- Grade 350W is acceptable for plate to a maximum thickness of 45 mm (1.75 in.) [insert plates to a maximum thickness of 50 mm (2 in.)] if fully killed and made to fine-grain practice.

### 2.2.4 ISO Specifications

98 | Plate furnished to ISO 630 in Grades E 275 and E 355 is acceptable within the following limitations:

- 98 | a. Grade E 275 in Qualities C and D for plate to a maximum thickness of 40 mm (1.5 in.) and with a maximum manganese content of 1.5% (heat).
- 98 | b. Grade E 355 in Qualities C and D for plate to a maximum thickness of 45 mm (1.75 in.) [insert plates to a maximum thickness of 50 mm (2 in.)].

### 98 | 2.2.5 National Standards

Plates produced and tested in accordance with the requirements of a recognized national standard and within the mechanical and chemical limitations of one of the grades listed in Table 2-2 are acceptable when approved by the purchaser. The requirements of this group do not apply to the ASTM, CSA, and ISO specifications listed in 2.2.2, 2.2.3, and 2.2.4. For the purposes of this standard, a *national standard* is a standard that has been sanctioned by the government of the country from which the standard originates.

Table 2-1—Maximum Permissible Alloy Content

Alloy	Heat Analysis (percent)	Notes
Columbium	0.05	1, 2, 3
Vanadium	0.10	1, 2, 4
Columbium ( $\leq 0.05\%$ ) plus vanadium	0.10	1, 2, 3
Nitrogen	0.015	1, 2, 4
Copper	0.35	1, 2
Nickel	0.50	1, 2
Chromium	0.25	1, 2
Molybdenum	0.08	1, 2

- 1. When the use of these alloys or combinations of them is not included in the material specification, their use shall be at the option of the plate producer, subject to the approval of the purchaser. These elements shall be reported when requested by the purchaser. When more restrictive limitations are included in the material specification, those shall govern.
- 2. On product analysis, the material shall conform to these requirements, subject to the product analysis tolerances of the specification.
- 3. When columbium is added either singly or in combination with vanadium, it shall be restricted to plates of 12.5 mm (0.50 in.) maximum thickness unless combined with 0.15% minimum silicon.
- 4. When nitrogen ( $\leq 0.015\%$ ) is added as a supplement to vanadium, it shall be reported, and the minimum ratio of vanadium to nitrogen shall be 4:1.

### 2.2.6 General Requirements for Delivery

2.2.6.1 The material furnished shall conform to the applicable requirements of the listed specifications but is not restricted with respect to the location of the place of manufacture.

2.2.6.2 This material is intended to be suitable for fusion welding. Welding technique is of fundamental importance, and welding procedures must provide welds whose strength and toughness are consistent with the plate material being joined. All welding performed to repair surface defects shall be done with low-hydrogen welding electrodes compatible in chemistry, strength, and quality with the plate material.

- 2.2.6.3 When specified by the plate purchaser, the steel shall be fully killed. When specified by the plate purchaser, fully killed steel shall be made to fine-grain practice.

2.2.6.4 For plate that is to be made to specifications that limit the maximum manganese content to less than 1.60%, the limit of the manganese content may be increased to 1.60% (heat) at the option of the plate producer to maintain the required strength level, provided that the maximum carbon content is reduced to 0.20% (heat) and the weldability of

98

Table 2-2—Acceptable Grades of Plate Material Produced to National Standards (See 2.2.5)

00	Mechanical Properties								Chemical Composition				
	Grade <sup>b</sup>	Tensile Strength <sup>a</sup>		Minimum Yield Strength <sup>c</sup>		Maximum Thickness		Maximum Percent Carbon		Maximum Percent Phosphorus and Sulfur			
		MPa	ksi	MPa	ksi	mm	in.	Heat	Product	Heat	Product		
00	235 <sup>d</sup>	360	52	510	74	235	34	20	0.75	0.20	0.24	0.04	0.05
00	250	400	58	530	77	250	36	40	1.5	0.23	0.27	0.04	0.05
00	275	430	62	560	81	275	40	40	1.5	0.25	0.29	0.04	0.05

<sup>a</sup>The location and number of test specimens, elongation and bend tests, and acceptance criteria are to be in accordance with the appropriate national standard, ISO standard, or ASTM specification.

<sup>b</sup>Semikilled or fully killed quality; as rolled, controlled-rolled or TMCP [20 mm (0.75 in.) maximum when controlled-rolled steel or TMCP is used in place of normalized steel], or normalized.

<sup>c</sup>Yield strength ÷ tensile strength ≤ 0.75, based on the minimum specified yield and tensile strength unless actual test values are required by the purchaser.

<sup>d</sup>Nonrimming only.

the plate is given consideration. The material shall be marked “Mod” following the specification listing. The material shall conform to the product analysis tolerances of Table B in ASTM A 6M/A 6.

**2.2.6.5** The use or presence of columbium, vanadium, nitrogen, copper, nickel, chromium, or molybdenum shall not exceed the limitations of Table 2-1 for all Group VI materials (see Table 2-3) and ISO 630, Grade E 355.

## 2.2.7 Heat Treatment of Plates

- **2.2.7.1** When specified by the plate purchaser, fully killed plates shall be heat treated to produce grain refinement by either normalizing or heating uniformly for hot forming. If the required treatment is to be obtained in conjunction with hot forming, the temperature to which the plates are heated for hot forming shall be equivalent to and shall not significantly exceed the normalizing temperature. If the treatment of the plates is not specified to be done at the plate producer’s plant, testing shall be carried out in accordance with 2.2.7.2.
- **2.2.7.2** When a plate purchaser elects to perform the required normalizing or fabricates by hot forming (see 2.2.7.1), the plates shall be accepted on the basis of mill tests made on full-thickness specimens heat treated in accordance with the plate purchaser’s order. If the heat-treatment temperatures are not indicated on the purchase order, the specimens shall be heat treated under conditions considered appropriate for grain refinement and for meeting the test requirements. The plate producer shall inform the plate purchaser of the procedure followed in treating the specimens at the steel mill.
- **2.2.7.3** On the purchase order, the plate purchaser shall indicate to the plate producer whether the producer shall perform the heat treatment of the plates.

- **2.2.7.4** Subject to the purchaser’s approval, controlled-rolled plates (plates produced by a mechanical-thermal rolling process designed to enhance notch toughness) may be used where normalized plates are required. Each controlled-rolled plate shall receive Charpy V-notch impact energy testing in accordance with 2.2.8, 2.2.9, and 2.2.10. When controlled-rolled steels are used, consideration should be given to the service conditions outlined in 3.3.3.

**2.2.7.5** The tensile tests shall be performed on each plate as heat treated.

## 2.2.8 Impact Testing of Plates

- **2.2.8.1** When required by the purchaser or by 2.2.7.4 and 2.2.9, a set of Charpy V-notch impact specimens shall be taken from plates after heat treatment (if the plates have been heat treated), and the specimens shall fulfill the stated energy requirements. Test coupons shall be obtained adjacent to a tension-test coupon. Each full-size impact specimen shall have its central axis as close to the plane of one-quarter plate thickness as the plate thickness will permit.
- 2.2.8.2** When it is necessary to prepare test specimens from separate coupons or when plates are furnished by the plate producer in a hot-rolled condition with subsequent heat treatment by the fabricator, the procedure shall conform to ASTM A 20.
- 2.2.8.3** An impact test shall be performed on three specimens taken from a single test coupon or test location. The average value of the specimens (with no more than one specimen value being less than the specified minimum value) shall comply with the specified minimum value. If more than one value is less than the specified minimum value, or if one value is less than two-thirds the specified minimum value,

three additional specimens shall be tested, and each of these must have a value greater than or equal to the specified minimum value.

**2.2.8.4** The test specimens shall be Charpy V-notch Type A specimens (see ASTM A 370), with the notch perpendicular to the surface of the plate being tested.

**2.2.8.5** For a plate whose thickness is insufficient to permit preparation of full-size specimens (10 mm × 10 mm), tests shall be made on the largest subsize specimens that can be prepared from the plate. Subsize specimens shall have a width along the notch of at least 80% of the material thickness.

**2.2.8.6** The impact energy values obtained from subsize specimens shall not be less than values that are proportional to the energy values required for full-size specimens of the same material.

**2.2.8.7** The testing apparatus, including the calibration of impact machines and the permissible variations in the temperature of specimens, shall conform to ASTM A 370 or an equivalent testing apparatus conforming to national standards or ISO standards.

## 2.2.9 Toughness Requirements

**2.2.9.1** The thickness and design metal temperature of all shell plates, shell reinforcing plates, shell insert plates, bottom plates welded to the shell, plates used for manhole and nozzle necks, plate-ring shell-nozzle flanges, blind flanges, and manhole cover plates shall be in accordance with Figure 2-1. Notch toughness evaluation of plate-ring flanges, blind flanges, and manhole cover plates shall be based on “governing thickness” as defined in 2.5.5.3. In addition, plates more than 40 mm (1.5 in.) thick shall be of killed steel made to fine-grain practice and heat treated by normalizing, normalizing and tempering, or quenching and tempering, and each plate as heat treated shall be impact tested according to 2.2.10.2. Each TMCP A 841 plate shall be impact tested according to 2.2.10.2 when used at design metal temperatures lower than the minimum temperatures indicated in Figure 2-1.

- **2.2.9.2** Plates less than or equal to 40 mm (1.5 in.) thick, except controlled-rolled plates (see 2.2.7.4), may be used at or above the design metal temperatures indicated in Figure 2-1 without being impact tested. To be used at design metal temperatures lower than the minimum temperatures indicated in Figure 2-1, plates shall demonstrate adequate notch toughness in accordance with 2.2.10.3 unless 2.2.10.2 or 2.2.10.4 has been specified by the purchaser. For heat-treated material, notch toughness shall be demonstrated on each plate as heat treated when 2.2.10.2 requirements are specified.

**2.2.9.3** Unless experience or special local conditions justify another assumption, the design metal temperature shall

be assumed to be 8°C (15°F) above the lowest one-day mean ambient temperature of the locality where the tank is to be installed. Isothermal lines of lowest one-day mean temperatures are shown in Figure 2-2. The temperatures are not related to refrigerated-tank temperatures (see 1.1.1).

**2.2.9.4** Plate used to reinforce shell openings and insert plates shall be of the same material as the shell plate to which they are attached or shall be of any appropriate material listed in Table 2-3 and Figure 2-1. Except for nozzle and manway necks, the material shall be of equal or greater yield and tensile strength and shall be compatible with the adjacent shell material (see 2.2.9.1 and 3.7.2.2, item e).

**2.2.9.5** The requirements in 2.2.9.4 apply only to shell nozzles and manholes. Materials for roof nozzles and manholes do not require special toughness.

## 2.2.10 Toughness Procedure

**2.2.10.1** When a material’s toughness must be determined, it shall be done by one of the procedures described in 2.2.10.2 through 2.2.10.4, as specified in 2.2.9.

**2.2.10.2** Each plate as rolled or heat treated shall be impact tested in accordance with 2.2.8 at or below the design metal temperature to show Charpy V-notch longitudinal (or transverse) values that fulfill the minimum requirements of Table 2-4 (see 2.2.8 for the minimum values for one specimen and for subsize specimens). As used here, the term *plate as rolled* refers to the unit plate rolled from a slab or directly from an ingot in its relation to the location and number of specimens, not to the condition of the plate.

**2.2.10.3** The thickest plate from each heat shall be impact tested in accordance with 2.2.8 and shall fulfill the impact requirements of 2.2.10.2 at the design metal temperature.

- **2.2.10.4** The manufacturer shall submit to the purchaser test data for plates of the material demonstrating that based on past production from the same mill, the material has provided the required toughness at the design metal temperature.

## ● 2.3 SHEETS

Sheets for fixed and floating roofs shall conform to ASTM A 570M/A 570, Grade 33. They shall be made by the open-hearth or basic oxygen process. Copper-bearing steel shall be used if specified on the purchase order. Sheets may be ordered on either a weight or a thickness basis, at the option of the tank manufacturer.

## 2.4 STRUCTURAL SHAPES

**2.4.1** Structural steel shall conform to one of the following:

- a. ASTM A 36M/A 36.
- b. ASTM A 131M/A 131.

Table 2-3a—Material Groups, SI Units (See Figure 2-1 and Note 1 Below)

Group I As Rolled, Semikilled		Group II As Rolled, Killed or Semikilled		Group III As Rolled, Killed Fine-Grain Practice		Group IIIA Normalized, Killed Fine-Grain Practice	
Material	Notes	Material	Notes	Material	Notes	Material	Notes
A 283M C	2	A 131M B	7	A 573M-400		A 131M CS	
A 285M C	2	A 36M	2, 6	A 516M-380		A 573M-400	10
A 131M A	2	G40.21M-260W		A 516M-415		A 516M-380	10
A 36M	2, 3	Grade 250	5, 8	G40.21M-260W	9	A 516M-415	10
Grade 235	3, 5			Grade 250	5, 9	G40.21M-260W	9, 10
Grade 250	6					Grade 250	5, 9, 10
Group IV As Rolled, Killed Fine-Grain Practice		Group IVA As Rolled, Killed Fine-Grain Practice		Group V Normalized, Killed Fine-Grain Practice		Group VI Normalized or Quenched and Tempered, Killed Fine-Grain Practice Reduced Carbon	
Material	Notes	Material	Notes	Material	Notes	Material	Notes
A 573M-450		A 662M C		A 573M-485	10	A 131M EH 36	
A 573M-485		A 573M-485	11	A 516M-450	10	A 633M C	
A 516M-450		G40.21M-300W	9, 11	A 516M-485	10	A 633M D	
A 516M-485		G40.21M-350W	9, 11	G40.21M-300W	9, 10	A 537M Class 1	
A 662M B				G40.21M-350W	9, 10	A 537M Class 2	13
G40.21M-300W	9					A 678M A	
G40.21M-350W	9					A 678M B	13
E 275	4, 9					A 737M B	
E 355	9					A 841	12, 13
Grade 275	5, 9						

Notes:

- Most of the listed material specification numbers refer to ASTM specifications (including Grade or Class); there are, however, some exceptions: G40.21M (including Grade) is a CSA specification; Grades E 275 and E 355 (including Quality) are contained in ISO 630; and Grade 235, Grade 250, and Grade 275 are related to national standards (see 2.2.5).
- Must be semikilled or killed.
- Thickness  $\leq 20$  mm.
- Maximum manganese content of 1.5%.
- Thickness 20 mm maximum when controlled-rolled steel is used in place of normalized steel.
- Manganese content shall be 0.80–1.2% by heat analysis for thicknesses greater than 20 mm, except that for each reduction of 0.01% below the specified carbon maximum, an increase of 0.06% manganese above the specified maximum will be permitted up to the maximum of 1.35%. Thicknesses  $\leq 20$  mm shall have a manganese content of 0.8–1.2% by heat analysis.
- Thickness  $\leq 25$  mm.
- Must be killed.
- Must be killed and made to fine-grain practice.
- Must be normalized.
- Must have chemistry (heat) modified to a maximum carbon content of 0.20% and a maximum manganese content of 1.60% (see 2.2.6.4).
- Produced by the thermo-mechanical control process (TMCP).
- See 3.7.4.6 for tests on simulated test coupons for material used in stress-relieved assemblies.

Table 2-3b—Material Groups, US Customary Units (See Figure 2-1 and Note 1 Below)

Group I As Rolled, Semikilled		Group II As Rolled, Killed or Semikilled		Group III As Rolled, Killed Fine-Grain Practice		Group IIIA Normalized, Killed Fine-Grain Practice	
Material	Notes	Material	Notes	Material	Notes	Material	Notes
A 283 C	2	A 131 B	7	A 573-58		A 131 CS	
A 285 C	2	A 36	2, 6	A 516-55		A 573-58	10
A 131 A	2	G40.21M-260W		A 516-60		A 516-55	10
A 36	2, 3	Grade 250	5, 8	G40.21M-260W	9	A 516-60	10
Grade 235	3, 5			Grade 250	5, 9	G40.21M-260W	9, 10
Grade 250	6					Grade 250	5, 9, 10

00

Group IV As Rolled, Killed Fine-Grain Practice		Group IVA As Rolled, Killed Fine-Grain Practice		Group V Normalized, Killed Fine-Grain Practice		Group VI Normalized or Quenched and Tempered, Killed Fine-Grain Practice Reduced Carbon	
Material	Notes	Material	Notes	Material	Notes	Material	Notes
A 573-65		A 662 C		A 573-70	10	A 131 EH 36	
A 573-70		A 573-70	11	A 516-65	10	A 633 C	
A 516-65		G40.21M-300W	9, 11	A 516-70	10	A 633 D	
A 516-70		G40.21M-350W	9, 11	G40.21M-300W	9, 10	A 537 Class 1	
A 662 B				G40.21M-350W	9, 10	A 537 Class 2	13
G40.21M-300W	9					A 678 A	
G40.21M-350W	9					A 678 B	13
E 275	4, 9					A 737 B	
E 355	9					A 841	12, 13
Grade 275	5, 9						

00

98

Notes:

- Most of the listed material specification numbers refer to ASTM specifications (including Grade or Class); there are, however, some exceptions: G40.21M (including Grade) is a CSA specification; Grades E 275 and E 355 (including Quality) are contained in ISO 630; and Grade 235, Grade 250, and Grade 275 are related to national standards (see 2.2.5).
- Must be semikilled or killed.
- Thickness ≤ 0.75 in.
- Maximum manganese content of 1.5%.
- Thickness 0.75 in. maximum when controlled-rolled steel is used in place of normalized steel.
- Manganese content shall be 0.80–1.2% by heat analysis for thicknesses greater than 0.75 inch, except that for each reduction of 0.01% below the specified carbon maximum, an increase of 0.06% manganese above the specified maximum will be permitted up to the maximum of 1.35%. Thicknesses ≤ 0.75 in. shall have a manganese content of 0.8–1.2% by heat analysis.
- Thickness ≤ 1 inch.
- Must be killed.
- Must be killed and made to fine-grain practice.
- Must be normalized.
- Must have chemistry (heat) modified to a maximum carbon content of 0.20% and a maximum manganese content of 1.60% (see 2.2.6.4).
- Produced by the thermo-mechanical control process (TMCP).
- See 3.7.4.6 for tests on simulated test coupons for material used in stress-relieved assemblies.

98

01

00

00

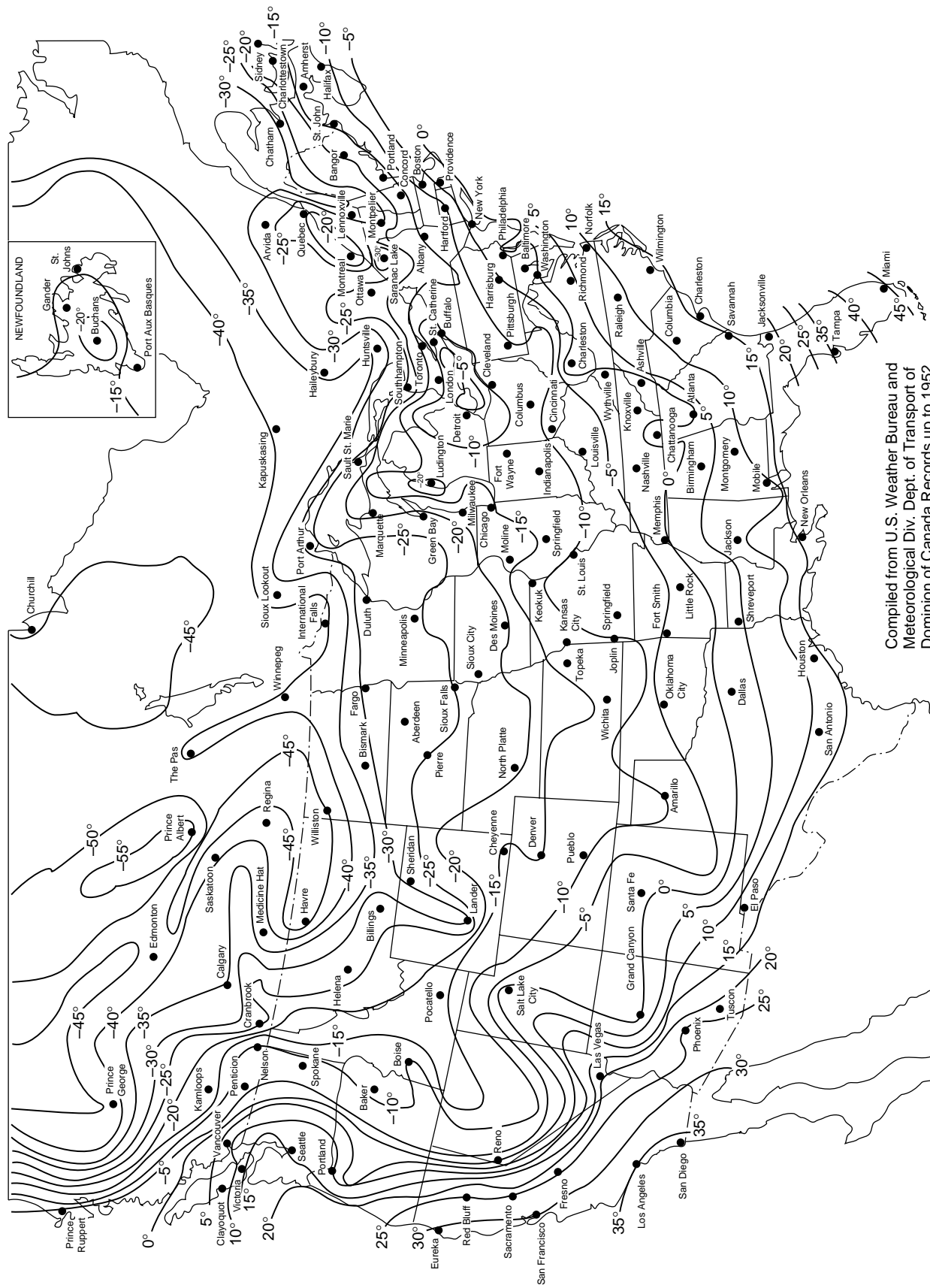

Compiled from U.S. Weather Bureau and  
Meteorological Div. Dept. of Transport of  
Dominion of Canada Records up to 1952.

Figure 2-2—Isothermal Lines of Lowest One-Day Mean Temperatures (°F)  
°C = (°F - 32)/1.8

Table 2-4—Minimum Impact Test Requirements for Plates (See Note)

Plate Material <sup>a</sup> and Thickness ( <i>t</i> ) in mm (in.)	Thickness		Average Impact Value of Three Specimens <sup>b</sup>			
			Longitudinal		Transverse	
	mm	in.	J	ft-lbf	J	ft-lbf
Groups I, II, III, and IIIA <i>t</i> ≤ maximum thicknesses in 2.2.2 through 2.2.5			20	15	18	13
Groups IV, IVA, V, and VI (except quenched and tempered and TMCP)	<i>t</i> ≤ 40	<i>t</i> ≤ 1.5	41	30	27	20
	40 < <i>t</i> ≤ 45	1.5 < <i>t</i> ≤ 1.75	48	35	34	25
	45 < <i>t</i> ≤ 50	1.75 < <i>t</i> ≤ 2	54	40	41	30
	50 < <i>t</i> ≤ 100	2 < <i>t</i> ≤ 4	68	50	54	40
Group VI (quenched and tempered and TMCP)	<i>t</i> ≤ 40	<i>t</i> ≤ 1.5	48	35	34	25
	40 < <i>t</i> ≤ 45	1.5 < <i>t</i> ≤ 1.75	54	40	41	30
	45 < <i>t</i> ≤ 50	1.75 < <i>t</i> ≤ 2	61	45	48	35
	50 < <i>t</i> ≤ 100	2 < <i>t</i> ≤ 4	68	50	54	40

<sup>a</sup>See Table 2-3.

<sup>b</sup>Interpolation is permitted to the nearest joule (ft-lbf).

Note: For plate ring flanges, the minimum impact test requirements for all thicknesses shall be those for *t* ≤ 40 mm (1.5 in.).

- 01 c. ASTM A 992M/A 992.  
 d. Structural Steels listed in AISC *Specification for Structural Steel Buildings, Allowable Stress Design*.  
 e. CSA G40.21-M, Grades 260W, 300W, 350W, 260WT, 300WT, and 350WT. Imperial unit equivalent grades of CSA Specification G40.21 are also acceptable.  
 01 f. ISO 630, Grade E 275, Qualities B, C, and D.  
 ● g. Recognized national standards. Structural steel that is produced in accordance with a recognized national standard and that meets the requirements of Table 2-2 is acceptable when approved by the purchaser.

- **2.4.2** All steel for structural shapes shall be made by the open-hearth, electric-furnace, or basic oxygen process. Copper-bearing steel is acceptable when approved by the purchaser.

## 2.5 PIPING AND FORGINGS

**2.5.1** Unless otherwise specified in this standard, pipe and pipe couplings and forgings shall conform to the specifications listed in 2.5.1.1 and 2.5.1.2 or to national standards equivalent to the specifications listed.

**2.5.1.1** The following specifications are acceptable for pipe and pipe couplings:

- API Spec 5L, Grades A, B, and X42.
- ASTM A 53, Grades A and B.
- ASTM A 106, Grades A and B.
- ASTM A 234M/A 234, Grade WPB.
- ASTM A 333M/A 333, Grades 1 and 6.
- ASTM A 334M/A 334, Grades 1 and 6.

g. ASTM A 420M/A 420, Grade WPL6.

h. ASTM A 524, Grades I and II.

i. ASTM A 671 (see 2.5.3).

**2.5.1.2** The following specifications are acceptable for forgings:

- ASTM A 105M/A 105.
- ASTM A 181M/A 181.
- ASTM A 350M/A 350, Grades LF1 and LF2.

**2.5.2** Unless ASTM A 671 pipe is used (electric-fusion-welded pipe) (see 2.5.3), material for shell nozzles and shell manhole necks shall be seamless pipe, seamless forging, or plate material as specified in 2.2.9.1. When shell materials are Group IV, IVA, V, or VI, seamless pipe shall comply with ASTM A 106, Grade B; ASTM A 524; ASTM A 333M/A 333, Grade 6; or ASTM A 334M/A 334, Grade 6.

**2.5.3** When ASTM A 671 pipe is used for shell nozzles and shell manhole necks, it shall comply with the following:

- Material selection shall be limited to Grades CA 55, CC 60, CC 65, CC 70, CD 70, CD 80, CE 55, and CE 60.
- The pipe shall be pressure tested in accordance with 8.3 of ASTM A 671.
- The plate specification for the pipe shall satisfy the requirements of 2.2.7, 2.2.8, and 2.2.9 that are applicable to that plate specification.
- Impact tests for qualifying the welding procedure for the pipe longitudinal welds shall be performed in accordance with 7.2.2.

**2.5.4** Weldable-quality pipe that conforms to the physical properties specified in any of the standards listed in 2.5.1 may be used for structural purposes with the allowable stresses stated in 3.10.3.

**2.5.5** Except as covered in 2.5.3, the toughness requirements of pipe and forgings to be used for shell nozzles and manholes shall be established as described in 2.5.5.1 through 2.5.5.4.

**2.5.5.1** Piping materials made according to ASTM A 333M/A 333, A 334M/A 334, A 350M/A 350, and A 420, Grade WPL6 may be used at design metal temperatures no lower than the impact test temperature required by the ASTM specification for the applicable material grade without additional impact tests (see 2.5.5.4).

**2.5.5.2** Other pipe and forging materials shall be classified under the material groups shown in Figure 2-1 as follows:

- a. Group IIA—API Spec 5L, Grades A, B, and X42; ASTM A 106, Grades A and B; ASTM A 53, Grades A and B; ASTM A 181M/A 181; ASTM A 105M/A 105; and A 234M/A 234, Grade WPB.
- b. Group VIA—ASTM A 524, Grades I and II.

**2.5.5.3** The materials in the groups listed in 2.5.5.2 may be used at nominal thicknesses, including corrosion allowance, at design metal temperatures no lower than those shown in Figure 2-1 without impact testing (see 2.5.5.4 and Figure 2-3). The governing thicknesses to be used in Figure 2-1 shall be as follows:

- a. For butt-welded joints, the nominal thickness of the thickest welded joint.
- b. For corner or lap welds, the thinner of the two parts joined.
- c. For nonwelded parts such as bolted blind flanges and manhole covers,  $\frac{1}{4}$  of their nominal thickness.

**2.5.5.4** When impact tests are required by 2.5.5.1 or 2.5.5.3, they shall be performed in accordance with the requirements, including the minimum energy requirements, of ASTM A 333M/A 333, Grade 6, for pipe or ASTM A 350M/A 350, Grade LF1, for forgings at a test temperature no higher than the design metal temperature. Except for the plate

specified in 2.2.9.2, the materials specified in 2.5.1 and 2.5.2 for shell nozzles, shell manhole necks, and all forgings used on shell openings shall have a minimum Charpy V-notch impact strength of 18 J (13 ft-lbf) (full-size specimen) at a temperature no higher than the design metal temperature.

## 2.6 FLANGES

**2.6.1** Hub, slip-on, welding, and welding-neck flanges shall conform to the material requirements of ASME B16.5 for forged carbon steel flanges. Plate material used for nozzle flanges shall have physical properties better than or equal to those required by ASME B16.5. Shell-nozzle flange material shall conform to 2.2.9.1.

- **2.6.2** For nominal pipe sizes greater than NPS 24, flanges that conform to ASME B16.47, Series B, may be used, subject to the purchaser's approval. Particular attention should be given to ensuring that mating flanges of appurtenances are compatible.

## ● 2.7 BOLTING

Bolting shall conform to ASTM A 307 or A 193M/A 193. A 325M/A 325 may be used for structural purposes only. The purchaser should specify on the order what shape of bolt heads and nuts is desired and whether regular or heavy dimensions are desired.

## 2.8 WELDING ELECTRODES

**2.8.1** For the welding of materials with a minimum tensile strength less than 550 MPa (80 ksi), the manual arc-welding electrodes shall conform to the E60 and E70 classification series (suitable for the electric current characteristics, the position of welding, and other conditions of intended use) in AWS A5.1 and shall conform to 5.2.1.10 as applicable.

**2.8.2** For the welding of materials with a minimum tensile strength of 550 through 585 MPa (80 through 85 ksi), the manual arc-welding electrodes shall conform to the E80XX-CX classification series in AWS A5.5.

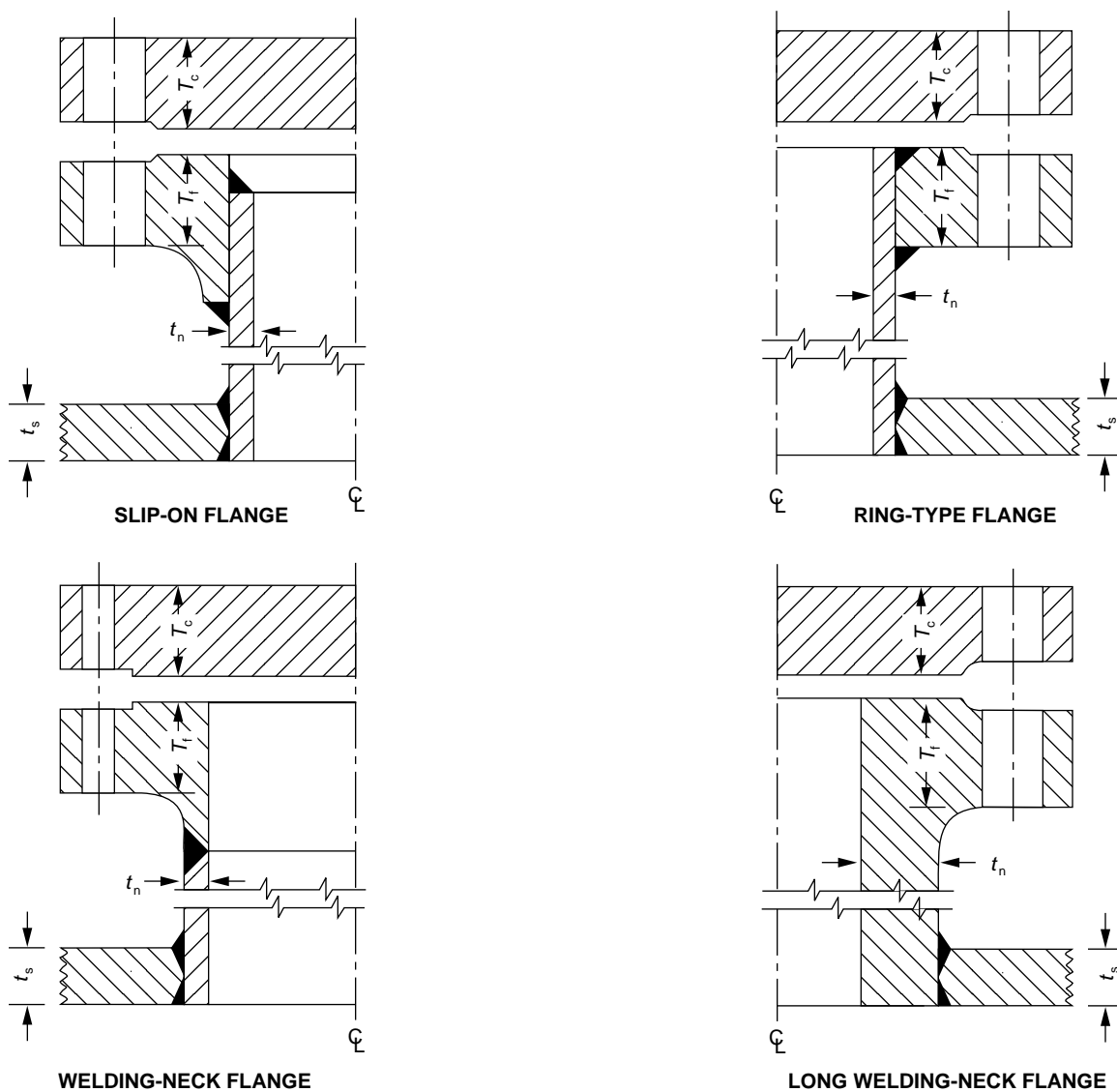

Notes:

1. Shell reinforcing plate is not included in the illustrations above.
2.  $t_s$  = shell thickness;  $t_n$  = nozzle neck thickness;  $T_f$  = flange thickness;  $T_c$  = bolted cover thickness.
3. The governing thickness for each component shall be as follows:

Components	Governing Thickness (thinner of)
Nozzle neck at shell	$t_n$ or $t_s$
Slip-on flange and nozzle neck	$t_n$ or $T_f$
Ring-type flange and nozzle neck	$t_n$ or $T_f$
Welding-neck flange and nozzle neck	$t_n$
Long welding-neck flange	$t_n$ or $t_s$
Nonwelded bolted cover	$1/4 T_c$

Figure 2-3—Governing Thickness for Impact Test Determination of Shell Nozzle and Manhole Materials (see 2.5.5.3)



## SECTION 3—DESIGN

### 3.1 JOINTS

#### 3.1.1 Definitions

The definitions in 3.1.1.1 through 3.1.1.8 apply to tank joint designs (see 7.1 for definitions that apply to welders and welding procedures).

**3.1.1.1 double-welded butt joint:** A joint between two abutting parts lying in approximately the same plane that is welded from both sides.

**3.1.1.2 single-welded butt joint with backing:** A joint between two abutting parts lying in approximately the same plane that is welded from one side only with the use of a strip bar or another suitable backing material.

**3.1.1.3 double-welded lap joint:** A joint between two overlapping members in which the overlapped edges of both members are welded with fillet welds.

**3.1.1.4 single-welded lap joint:** A joint between two overlapping members in which the overlapped edge of one member is welded with a fillet weld.

**3.1.1.5 butt-weld:** A weld placed in a groove between two abutting members. Grooves may be square, V-shaped (single or double), or U-shaped (single or double), or they may be either single or double beveled.

**3.1.1.6 fillet weld:** A weld of approximately triangular cross section that joins two surfaces at approximately right angles, as in a lap joint, tee joint, or corner joint.

**3.1.1.7 full-fillet weld:** A fillet weld whose size is equal to the thickness of the thinner joined member.

**3.1.1.8 tack weld:** A weld made to hold the parts of a weldment in proper alignment until the final welds are made.

#### 3.1.2 Weld Size

**3.1.2.1** The size of a groove weld shall be based on the joint penetration (that is, the depth of chamfering plus the root penetration when specified).

**3.1.2.2** The size of an equal-leg fillet weld shall be based on the leg length of the largest isosceles right triangle that can be inscribed within the cross section of the fillet weld. The size of an unequal-leg fillet weld shall be based on the leg lengths of the largest right triangle that can be inscribed within the cross section of the fillet weld.

#### 3.1.3 Restrictions on Joints

**3.1.3.1** Restrictions on the type and size of welded joints are given in 3.1.3.2 through 3.1.3.5.

**3.1.3.2** Tack welds shall not be considered as having any strength value in the finished structure.

**3.1.3.3** The minimum size of fillet welds shall be as follows: On plates 5 mm ( $3/16$  in.) thick, the weld shall be a full-fillet weld, and on plates more than 5 mm ( $3/16$  in.) thick, the weld thickness shall not be less than one-third the thickness of the thinner plate at the joint and shall be at least 5 mm ( $3/16$  in.).

**3.1.3.4** Single-welded lap joints are permissible only on bottom plates and roof plates.

**3.1.3.5** Lap-welded joints, as tack-welded, shall be lapped at least five times the nominal thickness of the thinner plate joined; however, with double-welded lap joints, the lap need not exceed 50 mm (2 in.), and with single-welded lap joints, the lap need not exceed 25 mm (1 in.).

#### 3.1.4 Welding Symbols

Welding symbols used on drawings shall be the symbols of the American Welding Society.

#### 3.1.5 Typical Joints

##### 3.1.5.1 General

Typical tank joints are shown in Figures 3-1, 3-2, 3-3A, 3-3B, and 3-3C. The wide faces of nonsymmetrical V- or U-butt joints may be on the outside or the inside of the tank shell at the option of the manufacturer. The tank shell shall be designed so that all courses are truly vertical.

##### 3.1.5.2 Vertical Shell Joints

a. Vertical shell joints shall be butt joints with complete penetration and complete fusion attained by double welding or other means that will obtain the same quality of deposited weld metal on the inside and outside weld surfaces to meet the requirements of 5.2.1 and 5.2.3. The suitability of the plate preparation and welding procedure shall be determined in accordance with 7.2.

b. Vertical joints in adjacent shell courses shall not be aligned but shall be offset from each other a minimum distance of  $5t$ , where  $t$  is the plate thickness of the thicker course at the point of offset.

##### 3.1.5.3 Horizontal Shell Joints

a. Horizontal shell joints shall have complete penetration and complete fusion; however, as an alternative, top angles may be attached to the shell by a double-welded lap joint. The suitability of the plate preparation and welding procedure shall be determined in accordance with 7.2.

b. Unless otherwise specified, abutting shell plates at horizontal joints shall have a common vertical centerline.

**3.1.5.4 Lap-Welded Bottom Joints**

Lap-welded bottom plates shall be reasonably rectangular and square edged. Three-plate laps in tank bottoms shall be at least 300 mm (12 in.) from each other, from the tank shell, from butt-welded annular-plate joints, and from joints between annular plates and the bottom. Lapping of two bottom plates on the butt-welded annular plates does not constitute a three-plate lap weld. When annular plates are used or are required by 3.5.1, they shall be butt-welded and shall have a radial width that provides at least 600 mm (24 in.) between the inside of the shell and any lap-welded joint in the remainder of the bottom. Bottom plates need to be welded on the top side only, with a continuous full-fillet weld on all seams. Unless annular bottom plates are used, the bottom plates under the bottom shell ring shall have the outer ends of the joints fitted and lap-welded to form a smooth bearing for the shell plates, as shown in Figure 3-3B.

**3.1.5.5 Butt-Welded Bottom Joints**

Butt-welded bottom plates shall have their parallel edges prepared for butt welding with either square or V grooves. Butt-welds shall be made using an appropriate weld joint configuration that yields a complete penetration weld. Typical permissible bottom butt-welds without a backing strip are the same as those shown in Figure 3-1. The use of a backing strip at least 3 mm (1/8 in.) thick tack welded to the underside of the plate is permitted. Butt-welds using a backing strip are shown in Figure 3-3A. If square grooves are employed, the root openings shall not be less than 6 mm (1/4 in.). A metal spacer shall be used to maintain the root opening between the adjoining plate edges unless the manufacturer submits another method of butt-welding the bottom for the purchaser's approval. Three-plate joints in the tank bottom shall be at least 300 mm (12 in.) from each other and from the tank shell.

**3.1.5.6 Bottom Annular-Plate Joints**

Bottom annular-plate radial joints shall be butt-welded in accordance with 3.1.5.5 and shall have complete penetration and complete fusion. The backing strip, if used, shall be compatible for welding the annular plates together.

**3.1.5.7 Shell-to-Bottom Fillet Welds**

a. For bottom and annular plates with a nominal thickness 12.5 mm (1/2 in.), and less, the attachment between the bottom edge of the lowest course shell plate and the bottom plate shall be a continuous fillet weld laid on each side of the shell plate. The size of each weld shall not be more than 12.5 mm (1/2 in.) and shall not be less than the nominal thickness of the thinner of the two plates joined (that is, the shell plate or the bottom plate immediately under the shell) or less than the following values:

Nominal Thickness of Shell Plate		Minimum Size of Fillet Weld	
(mm)	(in.)	(mm)	(in.)
5	0.1875	5	3/16
> 5 to 20	> 0.1875 to 0.75	6	1/4
> 20 to 32	> 0.75 to 1.25	8	5/16
> 32 to 45	> 1.25 to 1.75	10	3/8

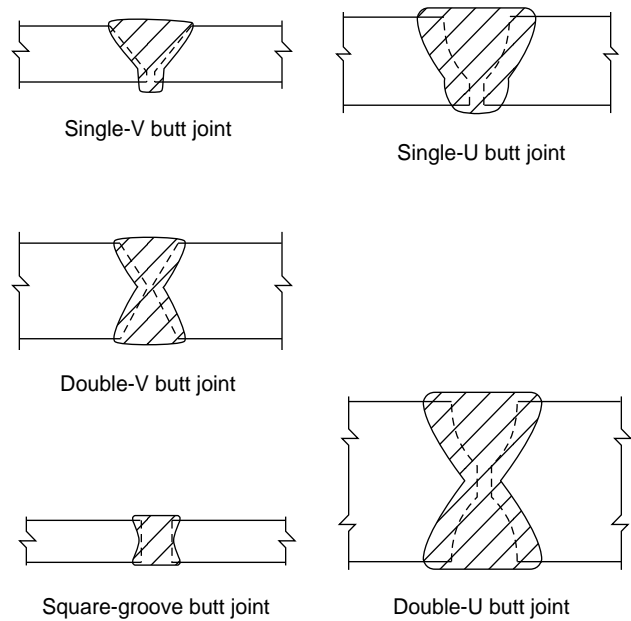

Note: See 3.1.5.2 for specific requirements for vertical shell joints.

Figure 3-1—Typical Vertical Shell Joints

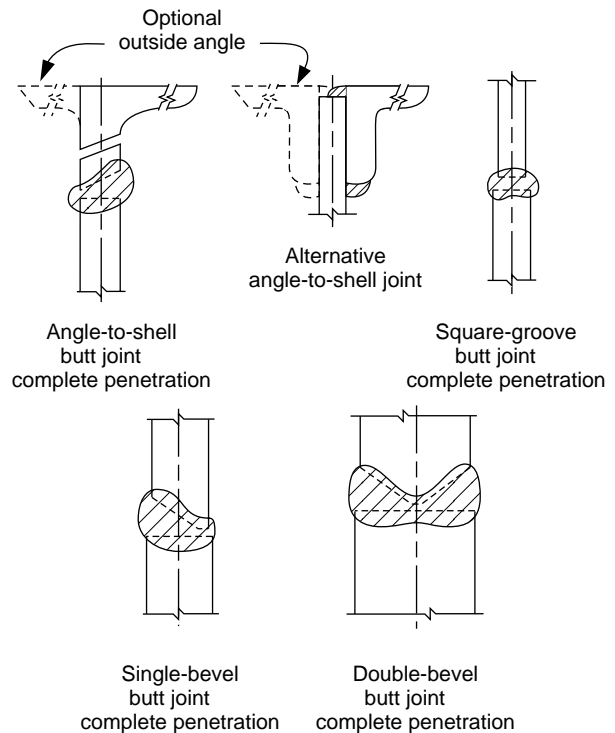

Note: See 3.1.5.3 for specific requirements for horizontal shell joints.

Figure 3-2—Typical Horizontal Shell Joints

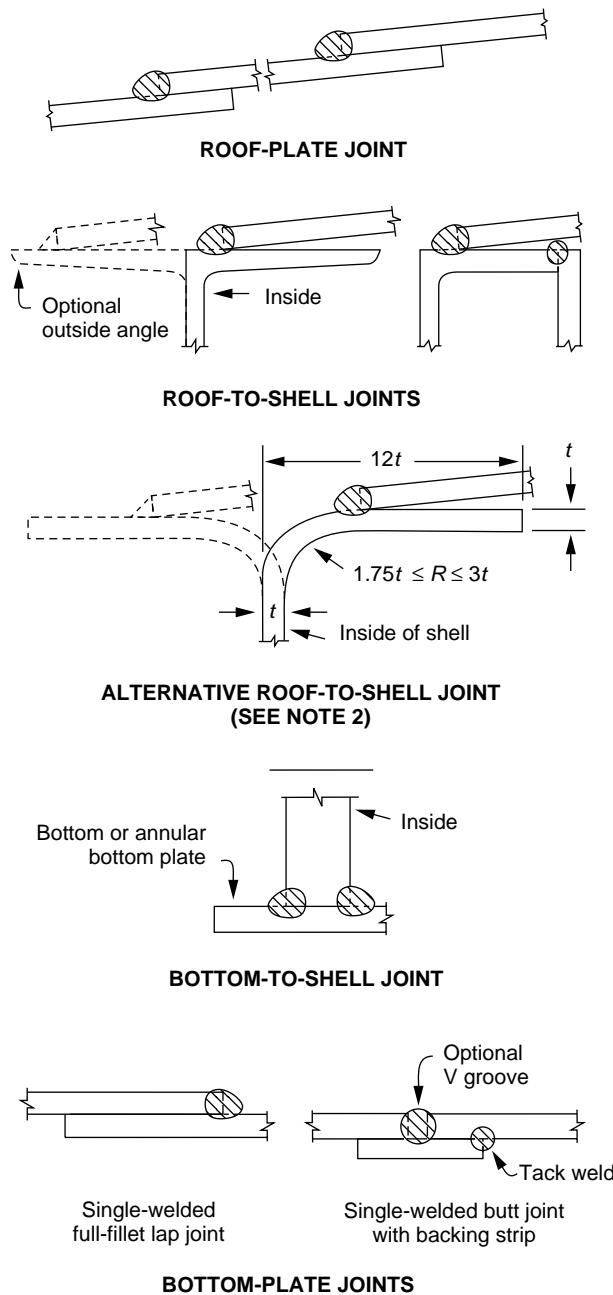

Notes:  
 1. See 3.1.5.4 through 3.1.5.9 for specific requirements for roof and bottom joints.  
 2. The alternative roof-to-shell joint is subject to the limitations of 3.1.5.9, item f.

Figure 3-3A—Typical Roof and Bottom Joints

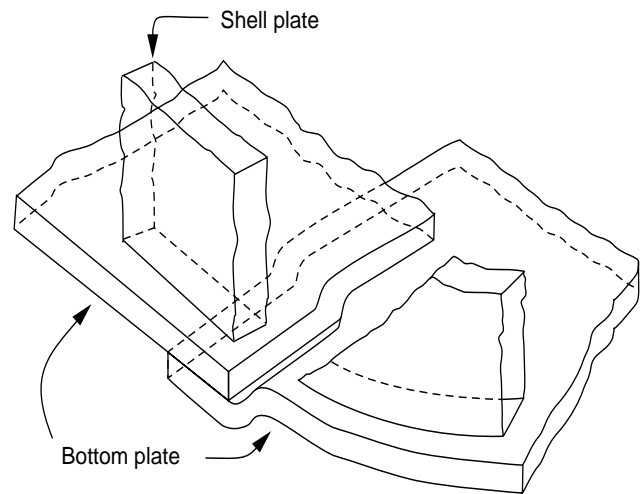

Figure 3-3B—Method for Preparing Lap-Welded Bottom Plates Under Tank Shell (See 3.1.5.4)

b. For annular plates with a nominal thickness greater than 12.5 mm (1/2 in.), the attachment welds shall be sized so that either the legs of the fillet welds or the groove depth plus the leg of the fillet for a combined weld is of a size equal to the annular-plate thickness (see Figure 3-3C), but shall not exceed the shell plate thickness.

c. Shell-to-bottom fillet welds for shell material in Groups IV, IVA, V, or VI shall be made with a minimum of two passes.

### 3.1.5.8 Wind Girder Joints

a. Full-penetration butt-welds shall be used for joining ring sections.

- b. Continuous welds shall be used for all horizontal top-side joints and for all vertical joints. Horizontal bottom-side joints shall be seal-welded if specified by the purchaser. Seal-welding should be considered to minimize the potential for entrapped moisture, which may cause corrosion.

### 3.1.5.9 Roof and Top-Angle Joints

a. Roof plates shall, as a minimum, be welded on the top side with a continuous full-fillet weld on all seams. Butt-welds are also permitted.

b. Roof plates shall be attached to the top angle of a tank with a continuous fillet weld on the top side only, as specified in 3.10.2.5.

c. The top-angle sections for self-supporting roofs shall be joined by butt-welds having complete penetration and fusion. Joint efficiency factors need not be applied in conforming to the requirements of 3.10.5 and 3.10.6.

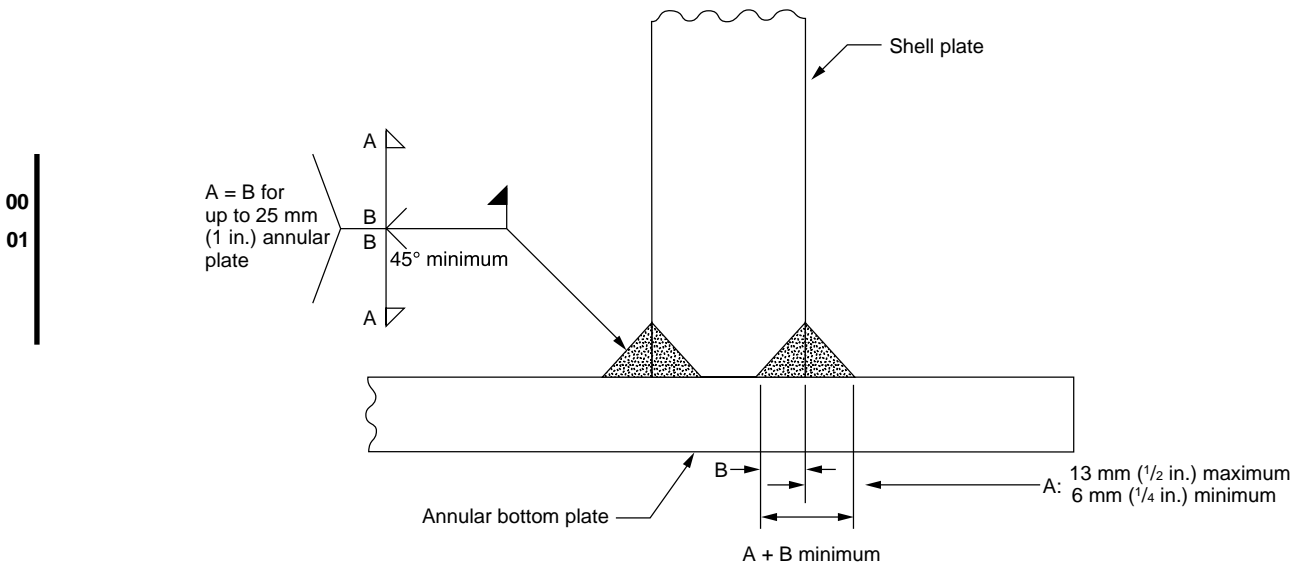

## Notes:

1. A = Fillet weld size limited to 13 mm (1/2 in.) maximum.
2. A + B = Thinner of shell or annular bottom plate thickness.
3. Groove weld B may exceed fillet size A only when annular plate is thicker than 25 mm (1 inch).

Figure 3-3C—Detail of Double Fillet-Groove Weld for Annular Bottom Plates With a Nominal Thickness Greater Than 13 mm (1/2 in.) (See 3.1.5.7, item b)

d. At the option of the manufacturer, for self-supporting roofs of the cone, dome, or umbrella type, the edges of the roof plates may be flanged horizontally to rest flat against the top angle to improve welding conditions.

- e. Except as specified for open-top tanks in 3.9, for self-supporting roofs in 3.10.5 and 3.10.6, and for tanks with the flanged roof-to-shell detail described in item f below, tank shells shall be supplied with top angles of not less than the following sizes: for tanks with a diameter less than or equal to 11 m (35 ft),  $51 \times 51 \times 4.8$  mm ( $2 \times 2 \times 3/16$  in.); for tanks with a diameter greater than 11 m (35 ft) but less than or equal to 18 m (60 ft),  $51 \times 51 \times 6.4$  mm ( $2 \times 2 \times 1/4$  in.); and for tanks with a diameter greater than 18 m (60 ft),  $76 \times 76 \times 9.5$  mm ( $3 \times 3 \times 3/8$  in.). At the purchaser's option, the outstanding leg of the top angle may extend inside or outside the tank shell.

f. For tanks with a diameter less than or equal to 9 m (30 ft) and a supported cone roof (see 3.10.4), the top edge of the shell may be flanged in lieu of installing a top angle. The bend radius and the width of the flanged edge shall conform to the details of Figure 3-3A. This construction may be used for any tank with a self-supporting roof (see 3.10.5 and 3.10.6) if the total cross-sectional area of the junction fulfills the stated area requirements for the construction of the top angle. No additional member, such as an angle or a bar, shall be added to the flanged roof-to-shell detail.

## 3.2 DESIGN CONSIDERATIONS

### ● 3.2.1 Design Factors

The purchaser shall state the design metal temperature (based on ambient temperatures), the design specific gravity, the corrosion allowance (if any), and the design wind velocity.

### ● 3.2.2 External Loads

The purchaser shall state the magnitude and direction of external loads or restraint, if any, for which the shell or shell connections must be designed. The design for such loadings shall be a matter of agreement between the purchaser and the manufacturer.

### ● 3.2.3 Protective Measures

The purchaser should give special consideration to foundations, corrosion allowance, hardness testing, and any other protective measures deemed necessary.

### 3.2.4 External Pressure

This standard does not contain provisions for the design of tanks subject to partial internal vacuum; however, tanks that meet the minimum requirements of this standard may be subjected to a partial vacuum of 0.25 kPa (1 in. of water) of water pressure.

### ● 3.2.5 Tank Capacity

**3.2.5.1** The purchaser shall specify the maximum capacity and the overfill protection level (or volume) requirement (see API Recommended Practice 2350).

**3.2.5.2** Maximum capacity is the volume of product in a tank when the tank is filled to its design liquid level as defined in 3.6.3.2 (see Appendix L).

**3.2.5.3** The net working capacity is the volume of available product under normal operating conditions. The net working capacity is equal to the maximum capacity (3.2.5.2) less the minimum operating volume remaining in the tank, less the overfill protection level (or volume) requirement (see Appendix L).

## 3.3 SPECIAL CONSIDERATIONS

### ● 3.3.1 Foundation

The selection of the tank site and the design and construction of the foundation shall be given careful consideration, as outlined in Appendix B, to ensure adequate tank support. The adequacy of the foundation is the responsibility of the purchaser.

### ● 3.3.2 Corrosion Allowances

When necessary, the purchaser, after giving consideration to the total effect of the liquid stored, the vapor above the liquid, and the atmospheric environment, shall specify the corrosion allowance to be provided for each shell course, for the bottom, for the roof, for nozzles and manholes, and for structural members.

### ● 3.3.3 Service Conditions

When the service conditions might include the presence of hydrogen sulfide or other conditions that could promote hydrogen-induced cracking, notably near the bottom of the shell at the shell-to-bottom connections, care should be taken to ensure that the materials of the tank and details of construction are adequate to resist hydrogen-induced cracking. The purchaser should consider limits on the sulfur content of the base and weld metals as well as appropriate quality control procedures in plate and tank fabrication. The hardness of the welds, including the heat-affected zones, in contact with these conditions should be considered. The weld metal and adjacent heat-affected zone often contain a zone of hardness well in excess of Rockwell C 22 and can be expected to be more susceptible to cracking than unwelded metal is. Any hardness criteria should be a matter of agreement between the purchaser and the manufacturer and should be based on an evaluation of the expected hydrogen sulfide concentration in the product, the possibility of moisture being present on the inside metal surface, and the strength and hardness characteristics of the base metal and weld metal.

### ● 3.3.4 Weld Hardness

When specified by the purchaser, the hardness of the weld metal for shell materials in Group IV, IVA, V, or VI shall be evaluated by one or both of the following methods:

a. The welding-procedure qualification tests for all welding shall include hardness tests of the weld metal and heat-affected zone of the test plate. The methods of testing and the acceptance standards shall be agreed upon by the purchaser and the manufacturer.

b. All welds deposited by an automatic process shall be hardness tested on the product-side surface. Unless otherwise specified, one test shall be conducted for each vertical weld, and one test shall be conducted for each 30 m (100 ft) of circumferential weld. The methods of testing and the acceptance standards shall be agreed upon by the purchaser and the manufacturer.

## 3.4 BOTTOM PLATES

● **3.4.1** All bottom plates shall have a minimum nominal thickness of 6 mm (<sup>1</sup>/<sub>4</sub> in.) [70 kPa (10.2 lbf/in.<sup>2</sup>) (see 2.2.1.2)], exclusive of any corrosion allowance specified by the purchaser for the bottom plates. Unless otherwise agreed to by the purchaser, all rectangular and sketch plates (bottom plates on which the shell rests that have one end rectangular) shall have a minimum nominal width of 1800 mm (72 in.).

**3.4.2** Bottom plates of sufficient size shall be ordered so that, when trimmed, at least a 25 mm (1 in.) width will project beyond the outside edge of the weld attaching the bottom to the shell plate.

**3.4.3** Bottom plates shall be welded in accordance with 3.1.5.4 or 3.1.5.5.

## 3.5 ANNULAR BOTTOM PLATES

**3.5.1** When the bottom shell course is designed using the allowable stress for materials in Group IV, IVA, V, or VI, butt-welded annular bottom plates shall be used (see 3.1.5.6). When the bottom shell course is of a material in Group IV, IVA, V, or VI and the maximum product stress (see 3.6.2.1) for the first shell course is less than or equal to 160 MPa (23,200 lbf/in.<sup>2</sup>) or the maximum hydrostatic test stress (see 3.6.2.2) for the first shell course is less than or equal to 172 MPa (24,900 lbf/in.<sup>2</sup>), lap-welded bottom plates (see 3.1.5.4) may be used in lieu of butt-welded annular bottom plates.

**3.5.2** Annular bottom plates shall have a radial width that provides at least 600 mm (24 in.) between the inside of the shell and any lap-welded joint in the remainder of the bottom and at least a 50 mm (2 in.) projection outside the shell. A greater radial width of annular plate is required when calculated as follows:

In SI units:

$$\frac{215t_b}{(HG)^{0.5}}$$

where

- $t_b$  = thickness of the annular plate (see 3.5.3), in mm,  
 $H$  = maximum design liquid level (see 3.6.3.2), in m,  
 $G$  = design specific gravity of the liquid to be stored.

In US Customary units:

$$\frac{390t_b}{(HG)^{0.5}}$$

where

- $t_b$  = thickness of the annular plate (see 3.5.3), (in.),  
 $H$  = maximum design liquid level (see 3.6.3.2), (ft),  
 $G$  = design specific gravity of the liquid to be stored.

**3.5.3** The thickness of the annular bottom plates shall not be less than the thicknesses listed in Table 3-1 plus any specified corrosion allowance.

**3.5.4** The ring of annular plates shall have a circular outside circumference but may have a regular polygonal shape inside the tank shell, with the number of sides equal to the number of annular plates. These pieces shall be welded in accordance with 3.1.5.6 and 3.1.5.7, item b.

**3.5.5** In lieu of annular plates, the entire bottom may be butt-welded provided that the requirements for annular plate thickness, welding, materials, and inspection are met for the annular distance specified in 3.5.2.

## 3.6 SHELL DESIGN

### 3.6.1 General

**3.6.1.1** The required shell thickness shall be the greater of the design shell thickness, including any corrosion allowance, or the hydrostatic test shell thickness, but the shell thickness shall not be less than the following:

Nominal Tank Diameter (See Note 1)		Nominal Plate Thickness (See Note 2)	
(m)	(ft)	(mm)	(in.)
< 15	< 50	5	3/16
15 to < 36	50 to < 120	6	1/4
36 to 60	120 to 200	8	5/16
> 60	> 200	10	3/8

Notes:

- 1. Unless otherwise specified by the purchaser, the nominal tank diameter shall be the centerline diameter of the bottom shell-course plates.
- 2. Nominal plate thickness refers to the tank shell as constructed. The thicknesses specified are based on erection requirements.
- 3. When specified by the purchaser, plate with a minimum nominal thickness of 6 millimeters may be substituted for 1/4-inch plate.

Table 3-1—Annular Bottom-Plate Thicknesses

Nominal Plate Thickness <sup>a</sup> of First Shell Course (mm)	SI Units			
	Hydrostatic Test Stress <sup>b</sup> in First Shell Course (MPa)			
	≤ 190	≤ 210	≤ 230	≤ 250
$t \leq 19$	6	6	7	9
$19 < t \leq 25$	6	7	10	11
$25 < t \leq 32$	6	9	12	14
$32 < t \leq 38$	8	11	14	17
$38 < t \leq 45$	9	13	16	19
Nominal Plate Thickness <sup>a</sup> of First Shell Course (in.)	US Customary			
	Hydrostatic Test Stress <sup>c</sup> in First Shell Course (lb/in <sup>2</sup> )			
	≤ 27,000	≤ 30,000	≤ 33,000	≤ 36,000
$t \leq 0.75$	1/4	1/4	9/32	11/32
$0.75 < t \leq 1.00$	1/4	9/32	3/8	7/16
$1.00 < t \leq 1.25$	1/4	11/32	15/32	9/16
$1.25 < t \leq 1.50$	5/16	7/16	9/16	11/16
$1.50 < t \leq 1.75$	11/32	1/2	5/8	3/4

<sup>a</sup>Nominal plate thickness refers to the tank shell as constructed.

<sup>b</sup>Hydrostatic test stresses are calculated from  $[4.9D(H - 0.3)]/t$  (see 3.6.3.2).

<sup>c</sup>Hydrostatic test stresses are calculated from  $[2.6D(H - 1)]/t$  (see 3.6.3.2).

Note: The thicknesses specified in the table, as well as the width specified in 3.5.2, are based on the foundation providing uniform support under the full width of the annular plate. Unless the foundation is properly compacted, particularly at the inside of a concrete ringwall, settlement will produce additional stresses in the annular plate.

- **3.6.1.2** Unless otherwise agreed to by the purchaser, the shell plates shall have a minimum nominal width of 1800 mm (72 in.). Plates that are to be butt-welded shall be properly squared.
- **3.6.1.3** The design shell thickness shall be computed on the basis that the tank is filled to a level  $H$  (see 3.6.3.2) with a liquid that has a specific gravity specified by the purchaser.
- **3.6.1.4** The hydrostatic test shell thickness shall be computed on the basis that the tank is filled to a level  $H$  (see 3.6.3.2) with water.
- **3.6.1.5** The calculated stress for each shell course shall not be greater than the stress permitted for the particular material used for the course. No shell course shall be thinner than the course above it.
- **3.6.1.6** The tank shell shall be checked for stability against buckling from the design wind velocity, as specified by the purchaser, in accordance with 3.9.7. If required for stability, intermediate girders, increased shell-plate thicknesses, or both shall be used. If the design wind velocity is not specified, the

maximum allowable wind velocity shall be calculated, and the result shall be reported to the purchaser at the time of the bid.

- **3.6.1.7** The manufacturer shall furnish to the purchaser a drawing that lists the following for each course:

- The required shell thicknesses for both the design condition (including corrosion allowance) and the hydrostatic test condition.
- The nominal thickness used.
- The material specification.
- The allowable stresses.

**3.6.1.8** Isolated radial loads on the tank shell, such as those caused by heavy loads on platforms and elevated walkways between tanks, shall be distributed by rolled structural sections, plate ribs, or built-up members.

### 3.6.2 Allowable Stress

**3.6.2.1** The maximum allowable product design stress,  $S_d$ , shall be as shown in Table 3-2. The net plate thicknesses—the actual thicknesses less any corrosion allowance—shall be used in the calculation. The design stress basis,  $S_d$ , shall be either two-thirds the yield strength or two-fifths the tensile strength, whichever is less.

**3.6.2.2** The maximum allowable hydrostatic test stress,  $S_t$ , shall be as shown in Table 3-2. The gross plate thicknesses, including any corrosion allowance, shall be used in the calculation. The hydrostatic test basis shall be either three-fourths the yield strength or three-sevenths the tensile strength, whichever is less.

**3.6.2.3** Appendix A permits an alternative shell design with a fixed allowable stress of 145 MPa (21,000 lbf/in.<sup>2</sup>) and a joint efficiency factor of 0.85 or 0.70. This design may only be used for tanks with shell thicknesses less than or equal to 12.5 mm ( $1/2$  in.).

**3.6.2.4** Structural design stresses shall conform to the allowable working stresses given in 3.10.3.

### 3.6.3 Calculation of Thickness by the 1-Foot Method

**3.6.3.1** The 1-foot method calculates the thicknesses required at design points 0.3 m (1 ft) above the bottom of each shell course. Appendix A permits only this design method. This method shall not be used for tanks larger than 60 m (200 ft) in diameter.

**3.6.3.2** The required minimum thickness of shell plates shall be the greater of the values computed by the following formulas:

In SI units:

$$t_d = \frac{4.9D(H-0.3)G}{S_d} + CA$$

$$t_t = \frac{4.9D(H-0.3)}{S_t}$$

where

- $t_d$  = design shell thickness, in mm,
- $t_t$  = hydrostatic test shell thickness, in mm,
- $D$  = nominal tank diameter, in m (see 3.6.1.1, Note 1),
- $H$  = design liquid level, in m,  
= height from the bottom of the course under consideration to the top of the shell including the top angle, if any; to the bottom of any overflow that limits the tank filling height; or to any other level specified by the purchaser, restricted by an internal floating roof, or controlled to allow for seismic wave action,
- $G$  = design specific gravity of the liquid to be stored, as specified by the purchaser,
- $CA$  = corrosion allowance, in mm, as specified by the purchaser (see 3.3.2),
- $S_d$  = allowable stress for the design condition, in MPa (see 3.6.2.1),
- $S_t$  = allowable stress for the hydrostatic test condition, in MPa (see 3.6.2.2).

In US Customary units:

$$t_d = \frac{2.6D(H-1)G}{S_d} + CA$$

$$t_t = \frac{2.6D(H-1)}{S_t}$$

where

- $t_d$  = design shell thickness (in.),
- $t_t$  = hydrostatic test shell thickness (in.),
- $D$  = nominal tank diameter, in ft (see 3.6.1.1, Note 1),
- $H$  = design liquid level, (ft),  
= height from the bottom of the course under consideration to the top of the shell including the top angle, if any; to the bottom of any overflow that limits the tank filling height; or to any other level specified by the purchaser, restricted by an internal floating roof, or controlled to allow for seismic wave action,
- $G$  = design specific gravity of the liquid to be stored, as specified by the purchaser,
- $CA$  = corrosion allowance, (in.), as specified by the purchaser (see 3.3.2),
- $S_d$  = allowable stress for the design condition, (lbf/in.<sup>2</sup>) (see 3.6.2.1),
- $S_t$  = allowable stress for the hydrostatic test condition, (lbf/in.<sup>2</sup>) (see 3.6.2.2).

00

Table 3-2—Permissible Plate Materials and Allowable Stresses

Plate Specification	Grade	Minimum Yield Strength MPa (psi)	Minimum Tensile Strength MPa (psi)	Product Design Stress $S_d$ MPa (psi)	Hydrostatic Test Stress $S_t$ MPa (psi)
ASTM Specifications					
A 283M (A 283)	C (C)	205 (30,000)	380 (55,000)	137 (20,000)	154 (22,500)
A 285M (A 285)	C (C)	205 (30,000)	380 (55,000)	137 (20,000)	154 (22,500)
A 131M (A 131)	A, B, CS (A, B, CS)	235 (34,000)	400 (58,000)	157 (22,700)	171 (24,900)
A 36M (A 36)	—	250 (36,000)	400 (58,000)	160 (23,200)	171 (24,900)
A 131M (A 131)	EH 36 (EH 36)	360 (51,000)	490 <sup>a</sup> (71,000 <sup>a</sup> )	196 (28,400)	210 (30,400)
A 573M (A 573)	400 (58)	220 (32,000)	400 (58,000)	147 (21,300)	165 (24,000)
A 573M (A 573)	450 (65)	240 (35,000)	450 (65,000)	160 (23,300)	180 (26,300)
A 573M (A 573)	485 (70)	290 (42,000)	485 <sup>a</sup> (70,000 <sup>a</sup> )	193 (28,000)	208 (30,000)
A 516M (A 516)	380 (55)	205 (30,000)	380 (55,000)	137 (20,000)	154 (22,500)
01 A 516M (A 516)	415 (60)	220 (32,000)	415 (60,000)	147 (21,300)	165 (24,000)
A 516M (A 516)	450 (65)	240 (35,000)	450 (65,000)	160 (23,300)	180 (26,300)
A 516M (A 516)	485 (70)	260 (38,000)	485 (70,000)	173 (25,300)	195 (28,500)
A 662M (A 662)	B (B)	275 (40,000)	450 (65,000)	180 (26,000)	193 (27,900)
A 662M (A 662)	C (C)	295 (43,000)	485 <sup>a</sup> (70,000 <sup>a</sup> )	194 (28,000)	208 (30,000)
A 537M (A 537)	1 (1)	345 (50,000)	485 <sup>a</sup> (70,000 <sup>a</sup> )	194 (28,000)	208 (30,000)
A 537M (A 537)	2 (2)	415 (60,000)	550 <sup>a</sup> (80,000 <sup>a</sup> )	220 (32,000)	236 (34,300)
A 633M (A 633)	C, D (C, D)	345 (50,000)	485 <sup>a</sup> (70,000 <sup>a</sup> )	194 (28,000)	208 (30,000)
A 678M (A 678)	A (A)	345 (50,000)	485 <sup>a</sup> (70,000 <sup>a</sup> )	194 (28,000)	208 (30,000)
A 678M (A 678)	B (B)	415 (60,000)	550 <sup>a</sup> (80,000 <sup>a</sup> )	220 (32,000)	236 (34,300)
A 737M (A 737)	B (B)	345 (50,000)	485 <sup>a</sup> (70,000 <sup>a</sup> )	194 (28,000)	208 (30,000)
A 841M (A 841)	Class 1 (Class 1)	345 (50,000)	485 <sup>a</sup> (70,000 <sup>a</sup> )	194 (28,000)	208 (30,000)
CSA Specifications					
G40.21M	260W	260 (37,700)	410 (59,500)	164 (23,800)	176 (25,500)
G40.21M	300W	300 (43,500)	450 (65,300)	180 (26,100)	193 (28,000)
G40.21M	350WT	350 (50,800)	480 <sup>a</sup> (69,600 <sup>a</sup> )	192 (27,900)	206 (29,800)
G40.21M	350W	350 (50,800)	450 (65,300)	180 (26,100)	193 (28,000)
National Standards					
	235	235 (34,000)	365 (52,600)	137 (20,000)	154 (22,500)
00	250	250 (36,000)	400 (58,300)	157 (22,700)	171 (25,000)
	275	275 (40,000)	430 (62,600)	167 (24,000)	184 (26,800)
ISO 630					
00 E 275	C, D	265 (38,400)	425 (61,900)	170 (24,700)	182 (26,500)
E 355	C, D	345 (50,000)	490 <sup>a</sup> (71,000 <sup>a</sup> )	196 (28,400)	210 (30,400)

- <sup>a</sup>By agreement between the purchaser and the manufacturer, the tensile strength of these materials may be increased to 515 MPa (75,000 psi) minimum and 620 MPa (90,000 psi) maximum [and to 585 MPa (85,000 psi) minimum and 690 MPa (100,000 psi) maximum for ASTM A 537M, Class 2, and A 678M, Grade B]. When this is done, the allowable stresses shall be determined as stated in 3.6.2.1 and 3.6.2.2.

### 3.6.4 Calculation of Thickness by the Variable-Design-Point Method

Note: This procedure normally provides a reduction in shell-course thicknesses and total material weight, but more important is its potential to permit construction of larger diameter tanks within the maximum plate thickness limitation. For background information, see L. P. Zick and R. V. McGrath, "Design of Large Diameter Cylindrical Shells."<sup>12</sup>

- **3.6.4.1** Design by the variable-design-point method gives shell thicknesses at design points that result in the calculated stresses being relatively close to the actual circumferential shell stresses. This method may only be used when the purchaser has not specified that the 1-foot method be used and when the following is true:

In SI units:

$$\frac{L}{H} \leq \frac{1000}{6}$$

where

- $L$  =  $(500 Dt)^{0.5}$ , in mm,
- $D$  = tank diameter, in m,
- $t$  = bottom-course shell thickness, in mm,
- $H$  = maximum design liquid level (see 3.6.3.2), in m.

In US Customary units:

$$\frac{L}{H} \leq 2$$

where

- $L$  =  $(6 Dt)^{0.5}$ , (in.),
- $D$  = tank diameter, (ft),
- $t$  = bottom-course shell thickness, (in.),
- $H$  = maximum design liquid level (see 3.6.3.2), (ft).

**3.6.4.2** The minimum plate thicknesses for both the design condition and the hydrostatic test condition shall be determined as outlined. Complete, independent calculations shall be made for all of the courses for the design condition, exclusive of any corrosion allowance, and for the hydrostatic test condition. The required shell thickness for each course shall be the greater of the design shell thickness plus any corrosion allowance or the hydrostatic test shell thickness, but the total shell thickness shall not be less than the shell thickness required by 3.6.1.1, 3.6.1.5, and 3.6.1.6. When a greater thickness is used for a shell course, the greater thickness may be used for subsequent calculations of the thicknesses of the shell courses above the course that has the greater thickness, provided the greater thickness is shown as the required design thickness on the manufacturer's drawing (see 3.6.1.7).

<sup>12</sup>L.P. Zick and R.V. McGrath, "Design of Large Diameter Cylindrical Shells," *Proceedings—Division of Refining, American Petroleum Institute, New York, 1968, Volume 48, pp. 1114–1140.*

**3.6.4.3** To calculate the bottom-course thicknesses, preliminary values  $t_{pd}$  and  $t_{pt}$  for the design and hydrostatic test conditions shall first be calculated from the formulas in 3.6.3.2.

**3.6.4.4** The bottom-course thicknesses  $t_{1d}$  and  $t_{1t}$  for the design and hydrostatic test conditions shall be calculated using the following formulas:

In SI units:

$$t_{1d} = \left( 1.06 - \frac{0.0696D}{H} \sqrt{\frac{HG}{S_d}} \right) \left( \frac{4.9HDG}{S_d} \right) + CA$$

In US Customary units:

$$t_{1d} = \left( 1.06 - \frac{0.463D}{H} \sqrt{\frac{HG}{S_d}} \right) \left( \frac{2.6HDG}{S_d} \right) + CA$$

Note: For the design condition,  $t_{1d}$  need not be greater than  $t_{pd}$ .

In SI units:

$$t_{1t} = \left( 1.06 - \frac{0.0696D}{H} \sqrt{\frac{H}{S_t}} \right) \left( \frac{4.9HD}{S_t} \right)$$

In US Customary units:

$$t_{1t} = \left( 1.06 - \frac{0.463D}{H} \sqrt{\frac{H}{S_t}} \right) \left( \frac{2.6HD}{S_t} \right)$$

Note: For the hydrostatic test condition,  $t_{1t}$  need not be greater than  $t_{pt}$ .

**3.6.4.5** To calculate the second-course thicknesses for both the design condition and the hydrostatic test condition, the value of the following ratio shall be calculated for the bottom course:

$$\frac{h_1}{(rt_1)^{0.5}}$$

where

- $h_1$  = height of the bottom shell course, in mm (in.),
- $r$  = nominal tank radius, in mm (in.),
- $t_1$  = actual thickness of the bottom shell course, less any thickness added for corrosion allowance, in mm (in.), used to calculate  $t_2$  (design). The total thickness of the bottom shell course shall be used to calculate  $t_2$  (hydrostatic test).

If the value of the ratio is less than or equal to 1.375,

$$t_2 = t_1$$

If the value of the ratio is greater than or equal to 2.625,

$$t_2 = t_{2a}$$

If the value of the ratio is greater than 1.375 but less than 2.625,

$$t_2 = t_{2a} + (t_1 - t_{2a}) \left[ 2.1 - \frac{h_1}{1.25(rt_1)^{0.5}} \right]$$

where

$t_2$  = minimum design thickness of the second shell course excluding any corrosion allowance, in mm (in.),

$t_{2a}$  = thickness of the second shell course, in mm (in.), as calculated for an upper shell course as described in 3.6.4.6.

The preceding formula for  $t_2$  is based on the same allowable stress being used for the design of the bottom and second courses. For tanks where the value of the ratio is greater than or equal to 2.625, the allowable stress for the second course may be lower than the allowable stress for the bottom course when the methods described in 3.6.4.6 through 3.6.4.8 are used.

**3.6.4.6** To calculate the upper-course thicknesses for both the design condition and the hydrostatic test condition, a preliminary value  $t_u$  for the upper-course thickness shall be calculated using the formulas in 3.6.3.2, and then the distance  $x$  of the variable design point from the bottom of the course shall be calculated using the lowest value obtained from the following

In SI units:

$$x_1 = 0.61 (rt_u)^{0.5} + 320 CH$$

$$x_2 = 1000 CH$$

$$x_3 = 1.22 (rt_u)^{0.5}$$

where

$t_u$  = thickness of the upper course at the girth joint, in mm,

$$C = [K^{0.5}(K-1)]/(1+K^{1.5}),$$

$$K = t_L / t_u,$$

$t_L$  = thickness of the lower course at the girth joint, in mm,

$H$  = design liquid level (see 3.6.3.2), in m.

In US Customary units:

$$x_1 = 0.61 (rt_u)^{0.5} + 3.84 CH$$

$$x_2 = 12 CH$$

$$x_3 = 1.22 (rt_u)^{0.5}$$

where

$t_u$  = thickness of the upper course at the girth joint, (in.),

$$C = [K^{0.5}(K-1)]/(1+K^{1.5}),$$

$$K = t_L / t_u,$$

$t_L$  = thickness of the lower course at the girth joint, (in.),

$H$  = design liquid level (see 3.6.3.2), (ft),

**3.6.4.7** The minimum thickness  $t_x$  for the upper shell courses shall be calculated for both the design condition ( $t_{dx}$ ) and the hydrostatic test condition ( $t_{tx}$ ) using the minimum value of  $x$  obtained from 3.6.4.6:

In SI units:

$$t_{dx} = \frac{4.9D \left( H - \frac{x}{1000} \right) G}{S_d} + CA$$

$$t_{tx} = \frac{4.9D \left( H - \frac{x}{1000} \right)}{S_t}$$

In US Customary units:

$$t_{dx} = \frac{2.6D \left( H - \frac{x}{12} \right) G}{S_d} + CA$$

$$t_{tx} = \frac{2.6D \left( H - \frac{x}{12} \right)}{S_t}$$

**3.6.4.8** The steps described in 3.6.4.6 and 3.6.4.7 shall be repeated using the calculated value of  $t_x$  as  $t_u$  until there is little difference between the calculated values of  $t_x$  in succession (repeating the steps twice is normally sufficient). Repeating the steps provides a more exact location of the design point for the course under consideration and, consequently, a more accurate shell thickness.

**3.6.4.9** The step-by-step calculations in Appendix K illustrate an application of the variable-design-point method to a tank with a diameter of 85 m (280 ft) and a height of 19.2 m (64 ft) to determine shell-plate thicknesses for the first three courses for the hydrostatic test condition only.

### 3.6.5 Calculation of Thickness by Elastic Analysis

For tanks where  $L/H$  is greater than 2, the selection of shell thicknesses shall be based on an elastic analysis that shows the calculated circumferential shell stresses to be below the allowable stresses given in Table 3-2. The boundary conditions for the analysis shall assume a fully plastic moment caused by yielding of the plate beneath the shell and zero radial growth.

## 3.7 SHELL OPENINGS

### 3.7.1 General

**3.7.1.1** The following requirements for shell openings are intended to restrict the use of appurtenances to those providing for attachment to the shell by welding.

00

00

- **3.7.1.2** The shell opening designs described in this standard are required, except for alternative designs allowed in 3.7.1.8.

**3.7.1.3** Flush-type cleanout fittings and flush-type shell connections shall conform to the designs specified in 3.7.7 and 3.7.8.

- **3.7.1.4** When a size intermediate to the sizes listed in Tables 3-3 through 3-14 is specified by the purchaser, the construction details and reinforcements shall conform to the next larger opening listed in the tables. The size of the opening or tank connection shall not be larger than the maximum size given in the appropriate table.

**3.7.1.5** Openings near the bottom of a tank shell will tend to rotate with vertical bending of the shell under hydrostatic loading. Shell openings in this area that have attached piping or other external loads shall be reinforced not only for the static condition but also for any loads imposed on the shell connections by the restraint of the attached piping to the shell rotation. The external loads shall be minimized, or the shell connections shall be relocated outside the rotation area. Appendix P provides a method for evaluating openings that conform to Table 3-6.

**3.7.1.6** Sheared or oxygen-cut surfaces on manhole necks, nozzle necks, reinforcing plates, and shell-plate openings shall be made uniform and smooth, with the corners rounded except where the surfaces are fully covered by attachment welds.

**3.7.1.7** The periphery of the insert plates shall have a 1:4 tapered transition to the thickness of the adjacent shell plates.

**3.7.1.8** With the approval of the purchaser, the shape and dimensions of the shell reinforcing plates, illustrated in Figures 3-4A, 3-4B, and 3-5 and dimensioned in the related tables, may be altered as long as the thickness, length, and width dimensions of the proposed shapes meet the area, welding, and spacing requirements outlined in 3.7.2. Reinforcement of shell openings that comply with API Standard 620 are acceptable alternatives. This statement of permissible alternatives of shell opening reinforcement does not apply to flush-type cleanout fittings and flush-type shell connections.

**3.7.1.9** The flange facing shall be suitable for the gasket and bolting employed. Gaskets shall be selected to meet the service environment so that the required seating load is compatible with the flange rating and facing, the strength of the flange, and its bolting.

## 3.7.2 Reinforcement and Welding

**3.7.2.1** Openings in tank shells larger than required to accommodate a NPS 2 flanged or threaded nozzle shall be reinforced. All shell-opening connections that require reinforcement (for example, nozzles, manholes, and cleanout openings) shall be attached by welds that fully penetrate the shell; however, the partial penetration illustrated in Figure 3-4B for insert-type reinforcement is permitted. The minimum

cross-sectional area of the required reinforcement shall not be less than the product of the vertical diameter of the hole cut in the shell and the nominal plate thickness, but when calculations are made for the maximum required thickness considering all design and hydrostatic test load conditions, the required thickness may be used in lieu of the nominal plate thickness. The cross-sectional area of the reinforcement shall be measured vertically, coincident with the diameter of the opening.

**3.7.2.2** Except for flush-type openings and connections, all effective reinforcements shall be made within a distance above and below the centerline of the shell opening equal to the vertical dimension of the hole in the tank shell plate. Reinforcement may be provided by any one or any combination of the following:

- a. The attachment flange of the fitting.
- b. The reinforcing plate.
- c. The portion of the neck of the fitting that may be considered as reinforcement according to 3.7.2.3.
- d. Excess shell-plate thickness. Reinforcement may be provided by any shell-plate thickness in excess of the thickness required by the governing load condition within a vertical distance above and below the centerline of the hole in the shell equal to the vertical dimension of the hole in the tank shell plate as long as the extra shell-plate thickness is the actual plate thickness used less the required thickness, calculated at the applicable opening, considering all load conditions and the corrosion allowance.
- e. The material in the nozzle neck. The strength of the material in the nozzle neck used for reinforcement should preferably be the same as the strength of the tank shell, but lower strength material is permissible as reinforcement as long as the neck material has minimum specified yield and tensile strengths not less than 70% and 80%, respectively, of the shell-plate minimum specified yield and tensile strengths. When the material strength is greater than or equal to the 70% and 80% minimum values, the area in the neck available for reinforcement shall be reduced by the ratio of the allowable stress in the neck, using the governing stress factors, to the allowable stress in the attached shell plate. No credit may be taken for the additional strength of any reinforcing material that has a higher allowable stress than that of the shell plate. Neck material that has a yield or tensile strength less than the 70% or 80% minimum values may be used, provided that no neck area is considered as effective reinforcement.

**3.7.2.3** The following portions of the neck of a fitting may be considered part of the area of reinforcement, except where prohibited by 3.7.2.2, item e:

- a. The portion extending outward from the outside surface of the tank shell plate to a distance equal to four times the neck-wall thickness or, if the neck-wall thickness is reduced within this distance, to the point of transition.
- b. The portion lying within the shell-plate thickness.
- c. The portion extending inward from the inside surface of the tank shell plate to the distance specified in item a.

Table 3-3—Thickness of Shell Manhole Cover Plate and Bolting Flange

Column 1	Column 2	Column 3	Column 4	Column 5	Column 6	Column 7	Column 8	Column 9	Column 10
Max. Design Liquid Level m (ft) <i>H</i>	Equivalent Pressure <sup>a</sup> kPa (psi)	Minimum Thickness of Cover Plate <sup>b</sup> ( <i>t<sub>c</sub></i> )				Minimum Thickness of Bolting Flange After Finishing <sup>b</sup> ( <i>t<sub>f</sub></i> )			
		500 mm (20 in.) Manhole	600 mm (24 in.) Manhole	750 mm (30 in.) Manhole	900 mm (36 in.) Manhole	500 mm (20 in.) Manhole	600 mm (24 in.) Manhole	750 mm (30 in.) Manhole	900 mm (36 in.) Manhole
6.4 (21)	63 (9.1)	8 ( <sup>5</sup> / <sub>16</sub> )	10 ( <sup>3</sup> / <sub>8</sub> )	11 ( <sup>7</sup> / <sub>16</sub> )	13 ( <sup>1</sup> / <sub>2</sub> )	6 ( <sup>1</sup> / <sub>4</sub> )	6 ( <sup>1</sup> / <sub>4</sub> )	8 ( <sup>5</sup> / <sub>16</sub> )	10 ( <sup>3</sup> / <sub>8</sub> )
8.2 (27)	80 (11.7)	10 ( <sup>3</sup> / <sub>8</sub> )	11 ( <sup>7</sup> / <sub>16</sub> )	13 ( <sup>1</sup> / <sub>2</sub> )	14 ( <sup>9</sup> / <sub>16</sub> )	6 ( <sup>1</sup> / <sub>4</sub> )	8 ( <sup>5</sup> / <sub>16</sub> )	10 ( <sup>3</sup> / <sub>8</sub> )	11 ( <sup>7</sup> / <sub>16</sub> )
9.8 (32)	96 (13.9)	10 ( <sup>3</sup> / <sub>8</sub> )	11 ( <sup>7</sup> / <sub>16</sub> )	14 ( <sup>9</sup> / <sub>16</sub> )	16 ( <sup>5</sup> / <sub>8</sub> )	6 ( <sup>1</sup> / <sub>4</sub> )	8 ( <sup>5</sup> / <sub>16</sub> )	11 ( <sup>7</sup> / <sub>16</sub> )	13 ( <sup>1</sup> / <sub>2</sub> )
12 (40)	118 (17.4)	11 ( <sup>7</sup> / <sub>16</sub> )	13 ( <sup>1</sup> / <sub>2</sub> )	16 ( <sup>5</sup> / <sub>8</sub> )	18 ( <sup>11</sup> / <sub>16</sub> )	8 ( <sup>5</sup> / <sub>16</sub> )	10 ( <sup>3</sup> / <sub>8</sub> )	13 ( <sup>1</sup> / <sub>2</sub> )	14 ( <sup>9</sup> / <sub>16</sub> )
14 (45)	137 (19.5)	13 ( <sup>1</sup> / <sub>2</sub> )	14 ( <sup>9</sup> / <sub>16</sub> )	16 ( <sup>5</sup> / <sub>8</sub> )	19 ( <sup>3</sup> / <sub>4</sub> )	10 ( <sup>3</sup> / <sub>8</sub> )	11 ( <sup>7</sup> / <sub>16</sub> )	13 ( <sup>1</sup> / <sub>2</sub> )	16 ( <sup>5</sup> / <sub>8</sub> )
16 (54)	157 (23.4)	13 ( <sup>1</sup> / <sub>2</sub> )	14 ( <sup>9</sup> / <sub>16</sub> )	18 ( <sup>11</sup> / <sub>16</sub> )	21 ( <sup>13</sup> / <sub>16</sub> )	10 ( <sup>3</sup> / <sub>8</sub> )	11 ( <sup>7</sup> / <sub>16</sub> )	14 ( <sup>9</sup> / <sub>16</sub> )	18 ( <sup>11</sup> / <sub>16</sub> )
20 (65)	196 (28.2)	14 ( <sup>9</sup> / <sub>16</sub> )	16 ( <sup>5</sup> / <sub>8</sub> )	19 ( <sup>3</sup> / <sub>4</sub> )	22 ( <sup>7</sup> / <sub>8</sub> )	11 ( <sup>7</sup> / <sub>16</sub> )	13 ( <sup>1</sup> / <sub>2</sub> )	16 ( <sup>5</sup> / <sub>8</sub> )	19 ( <sup>3</sup> / <sub>4</sub> )
23 (75)	226 (32.5)	16 ( <sup>5</sup> / <sub>8</sub> )	18 ( <sup>11</sup> / <sub>16</sub> )	21 ( <sup>13</sup> / <sub>16</sub> )	24 ( <sup>15</sup> / <sub>16</sub> )	12.5 ( <sup>1</sup> / <sub>2</sub> )	14 ( <sup>9</sup> / <sub>16</sub> )	18 ( <sup>11</sup> / <sub>16</sub> )	21 ( <sup>13</sup> / <sub>16</sub> )

<sup>a</sup>Equivalent pressure is based on water loading.

<sup>b</sup>For addition of corrosion allowance, see 3.7.5.2.

Note: See Figure 3-4A.

Table 3-4—Dimensions for Shell Manhole Neck Thickness

Thickness of Shell and Manhole Reinforcing Plate <sup>a</sup> <i>t</i> and <i>T</i>	Minimum Neck Thickness <sup>b,c</sup> <i>t<sub>n</sub></i> mm (in.)			
	For Manhole Diameter 500 mm (20 in.)	For Manhole Diameter 600 mm (24 in.)	For Manhole Diameter 750 mm (30 in.)	For Manhole Diameter 900 mm (36 in.)
5 ( <sup>3</sup> / <sub>16</sub> )	5 ( <sup>3</sup> / <sub>16</sub> )	5 ( <sup>3</sup> / <sub>16</sub> )	5 ( <sup>3</sup> / <sub>16</sub> )	5 ( <sup>3</sup> / <sub>16</sub> )
6 ( <sup>1</sup> / <sub>4</sub> )	6 ( <sup>1</sup> / <sub>4</sub> )	6 ( <sup>1</sup> / <sub>4</sub> )	6 ( <sup>1</sup> / <sub>4</sub> )	6 ( <sup>1</sup> / <sub>4</sub> )
8 ( <sup>5</sup> / <sub>16</sub> )	6 ( <sup>1</sup> / <sub>4</sub> )	6 ( <sup>1</sup> / <sub>4</sub> )	8 ( <sup>5</sup> / <sub>16</sub> )	8 ( <sup>5</sup> / <sub>16</sub> )
10 ( <sup>3</sup> / <sub>8</sub> )	6 ( <sup>1</sup> / <sub>4</sub> )	6 ( <sup>1</sup> / <sub>4</sub> )	8 ( <sup>5</sup> / <sub>16</sub> )	10 ( <sup>3</sup> / <sub>8</sub> )
11 ( <sup>7</sup> / <sub>16</sub> )	6 ( <sup>1</sup> / <sub>4</sub> )	6 ( <sup>1</sup> / <sub>4</sub> )	8 ( <sup>5</sup> / <sub>16</sub> )	10 ( <sup>3</sup> / <sub>8</sub> )
12.5 ( <sup>1</sup> / <sub>2</sub> )	6 ( <sup>1</sup> / <sub>4</sub> )	6 ( <sup>1</sup> / <sub>4</sub> )	8 ( <sup>5</sup> / <sub>16</sub> )	10 ( <sup>3</sup> / <sub>8</sub> )
14 ( <sup>9</sup> / <sub>16</sub> )	6 ( <sup>1</sup> / <sub>4</sub> )	6 ( <sup>1</sup> / <sub>4</sub> )	8 ( <sup>5</sup> / <sub>16</sub> )	10 ( <sup>3</sup> / <sub>8</sub> )
16 ( <sup>5</sup> / <sub>8</sub> )	6 ( <sup>1</sup> / <sub>4</sub> )	6 ( <sup>1</sup> / <sub>4</sub> )	8 ( <sup>5</sup> / <sub>16</sub> )	10 ( <sup>3</sup> / <sub>8</sub> )
18 ( <sup>11</sup> / <sub>16</sub> )	6 ( <sup>1</sup> / <sub>4</sub> )	6 ( <sup>1</sup> / <sub>4</sub> )	8 ( <sup>5</sup> / <sub>16</sub> )	10 ( <sup>3</sup> / <sub>8</sub> )
19 ( <sup>3</sup> / <sub>4</sub> )	6 ( <sup>1</sup> / <sub>4</sub> )	6 ( <sup>1</sup> / <sub>4</sub> )	8 ( <sup>5</sup> / <sub>16</sub> )	10 ( <sup>3</sup> / <sub>8</sub> )
21 ( <sup>13</sup> / <sub>16</sub> )	8 ( <sup>5</sup> / <sub>16</sub> )	6 ( <sup>1</sup> / <sub>4</sub> )	8 ( <sup>5</sup> / <sub>16</sub> )	10 ( <sup>3</sup> / <sub>8</sub> )
22 ( <sup>7</sup> / <sub>8</sub> )	10 ( <sup>3</sup> / <sub>8</sub> )	8 ( <sup>5</sup> / <sub>16</sub> )	8 ( <sup>5</sup> / <sub>16</sub> )	10 ( <sup>3</sup> / <sub>8</sub> )
24 ( <sup>15</sup> / <sub>16</sub> )	11 ( <sup>7</sup> / <sub>16</sub> )	11 ( <sup>7</sup> / <sub>16</sub> )	11 ( <sup>7</sup> / <sub>16</sub> )	11 ( <sup>7</sup> / <sub>16</sub> )
25 (1)	11 ( <sup>7</sup> / <sub>16</sub> )	11 ( <sup>7</sup> / <sub>16</sub> )	11 ( <sup>7</sup> / <sub>16</sub> )	11 ( <sup>7</sup> / <sub>16</sub> )
27 (1 <sup>1</sup> / <sub>16</sub> )	11 ( <sup>7</sup> / <sub>16</sub> )	11 ( <sup>7</sup> / <sub>16</sub> )	11 ( <sup>7</sup> / <sub>16</sub> )	11 ( <sup>7</sup> / <sub>16</sub> )
28 (1 <sup>1</sup> / <sub>8</sub> )	13 ( <sup>1</sup> / <sub>2</sub> )	13 ( <sup>1</sup> / <sub>2</sub> )	13 ( <sup>1</sup> / <sub>2</sub> )	13 ( <sup>1</sup> / <sub>2</sub> )
30 (1 <sup>3</sup> / <sub>16</sub> )	14 ( <sup>9</sup> / <sub>16</sub> )	14 ( <sup>9</sup> / <sub>16</sub> )	14 ( <sup>9</sup> / <sub>16</sub> )	14 ( <sup>9</sup> / <sub>16</sub> )
32 (1 <sup>1</sup> / <sub>4</sub> )	16 ( <sup>5</sup> / <sub>8</sub> )	14 ( <sup>9</sup> / <sub>16</sub> )	14 ( <sup>9</sup> / <sub>16</sub> )	14 ( <sup>9</sup> / <sub>16</sub> )
33 (1 <sup>5</sup> / <sub>16</sub> )	16 ( <sup>5</sup> / <sub>8</sub> )	16 ( <sup>5</sup> / <sub>8</sub> )	16 ( <sup>5</sup> / <sub>8</sub> )	16 ( <sup>5</sup> / <sub>8</sub> )
34 (1 <sup>3</sup> / <sub>8</sub> )	17 ( <sup>11</sup> / <sub>16</sub> )	16 ( <sup>5</sup> / <sub>8</sub> )	16 ( <sup>5</sup> / <sub>8</sub> )	16 ( <sup>5</sup> / <sub>8</sub> )
36 (1 <sup>7</sup> / <sub>16</sub> )	17 ( <sup>11</sup> / <sub>16</sub> )	17 ( <sup>11</sup> / <sub>16</sub> )	17 ( <sup>11</sup> / <sub>16</sub> )	17 ( <sup>11</sup> / <sub>16</sub> )
40 (1 <sup>1</sup> / <sub>2</sub> )	19 ( <sup>3</sup> / <sub>4</sub> )	19 ( <sup>3</sup> / <sub>4</sub> )	19 ( <sup>3</sup> / <sub>4</sub> )	19 ( <sup>3</sup> / <sub>4</sub> )

<sup>a</sup>If a shell plate thicker than required is used for the product and hydrostatic loading (see 3.6), the excess shell-plate thickness, within a vertical distance both above and below the centerline of the hole in the tank shell plate equal to the vertical dimension of the hole in the tank shell plate, may be considered as reinforcement, and the thickness *T* of the manhole reinforcing plate may be decreased accordingly. In such cases, the reinforcement and the attachment welding shall conform to the design limits for reinforcement of shell openings specified in 3.7.2.

<sup>b</sup>Reinforcement shall be added if the neck thickness is less than that shown in the column. The minimum neck thickness shall be the thickness of the shell plate or the allowable finished thickness of the bolting flange (see Table 3-3), whichever is thinner, but in no case shall the neck in a built-up manhole be thinner than the thicknesses given. If the neck thickness on a built-up manhole is greater than the required minimum, the manhole reinforcing plate may be decreased accordingly within the limits specified in 3.7.2.

<sup>c</sup>For addition of corrosion allowance, see 3.7.5.2.

**Table 3-5—Dimensions for Bolt Circle Diameter  $D_b$  and Cover Plate Diameter  $D_c$  for Shell Manholes**

Column 1	Column 2	Column 3
Manhole Diameter mm (in.)	Bolt Circle Diameter $D_b$ mm (in.)	Cover Plate Diameter $D_c$ mm (in.)
500 (20)	656 (26 <sup>1</sup> / <sub>4</sub> )	720 (28 <sup>3</sup> / <sub>4</sub> )
600 (24)	756 (30 <sup>1</sup> / <sub>4</sub> )	820 (32 <sup>3</sup> / <sub>4</sub> )
750 (30)	906 (36 <sup>1</sup> / <sub>4</sub> )	970 (38 <sup>3</sup> / <sub>4</sub> )
900 (36)	1056 (42 <sup>1</sup> / <sub>4</sub> )	1120 (44 <sup>3</sup> / <sub>4</sub> )

Note: See Figure 3-4A.

**3.7.2.4** The aggregate strength of the weld attaching a fitting to the shell plate, an intervening reinforcing plate, or both shall at least equal the proportion of the forces passing through the entire reinforcement that is calculated to pass through the fitting.

**3.7.2.5** The aggregate strength of the welds attaching any intervening reinforcing plate to the shell plate shall at least equal the proportion of the forces passing through the entire reinforcement that is calculated to pass through the reinforcing plate.

**3.7.2.6** The attachment weld to the shell along the outer periphery of a flanged fitting or reinforcing plate shall be considered effective only for the parts lying outside the area bounded by vertical lines drawn tangent to the shell opening; however, the outer peripheral weld shall be applied completely around the reinforcement. All of the inner peripheral weld shall be considered effective. The strength of the effective attachment weld shall be considered as the weld's shear resistance at the stress value given for fillet welds in 3.10.3.5. The size of the outer peripheral weld shall be equal to the thickness of the shell plate or reinforcing plate, whichever is thinner, but shall not be greater than 38 mm (1<sup>1</sup>/<sub>2</sub> in.). When low-type nozzles are used with a reinforcing plate that extends to the tank bottom (see Figure 3-5), the size of the portion of the peripheral weld that attaches the reinforcing plate to the bottom plate shall conform to 3.1.5.7. The inner peripheral weld shall be large enough to sustain the remainder of the loading.

**3.7.2.7** When two or more openings are located so that the outer edges (toes) of their normal reinforcing-plate fillet welds are closer than eight times the size of the larger of the fillet welds, with a minimum of 150 mm (6 in.), they shall be treated and reinforced as follows:

- All such openings shall be included in a single reinforcing plate that shall be proportioned for the largest opening in the group.
- If the normal reinforcing plates for the smaller openings in the group, considered separately, fall within the area limits of the solid portion of the normal plate for the largest opening, the smaller openings may be included in the normal plate for

the largest opening without an increase in the size of the plate, provided that if any opening intersects the vertical centerline of another opening, the total width of the final reinforcing plate along the vertical centerline of either opening is not less than the sum of the widths of the normal plates for the openings involved.

c. If the normal reinforcing plates for the smaller openings in the group, considered separately, do not fall within the area limits of the solid portion of the normal plate for the largest opening, the group reinforcing-plate size and shape shall include the outer limits of the normal reinforcing plates for all the openings in the group. A change in size from the outer limits of the normal plate for the largest opening to the outer limits of that for the smaller opening farthest from the largest opening shall be accomplished by uniform straight taper unless the normal plate for any intermediate opening would extend beyond these limits, in which case uniform straight tapers shall join the outer limits of the several normal plates. The provisions of item b with respect to openings on the same or adjacent vertical centerlines also apply in this case.

### 3.7.3 Spacing of Welds Around Connections

See Figure 3-22 for spacing requirements listed in 3.7.3.1 through 3.7.3.4.

Note: Additional weld spacing requirements exist in this standard. Other paragraphs and tables dealing with nozzles and manholes may increase the minimum spacing.

Note: Whenever stress relief or thermal stress relief is used in this standard, it shall mean post-weld heat treatment.

**3.7.3.1** For nonstress-relieved welds on shell plates over 12.5 mm (1/2 in.) thick, the minimum spacing between penetration connections and adjacent shell-plate joints shall be governed by the following:

- The outer edge or toe of fillet around a penetration, around the periphery of a thickened insert plate, or around the periphery of a reinforcing plate shall be spaced at least the greater of eight times the weld size or 250 mm (10 in.) from the centerline of any butt-welded shell joints.
- The welds around the periphery of a thickened insert plate, around a reinforcing insert plate, or around a reinforcing plate shall be spaced at least the greater of eight times the larger weld size or 150 mm (6 in.) from each other.

**3.7.3.2** Where stress-relieving of the periphery weld has been performed prior to welding of the adjacent shell joint or where a nonstress-relieved weld is on a shell plate less than or equal to 12.5 mm (1/2 in.) thick, the spacing may be reduced to 150 mm (6 in.) from vertical joints or to the greater of 75 mm (3 in.) or 2<sup>1</sup>/<sub>2</sub> times the shell thickness from horizontal joints. The spacing between the welds around the periphery of a thickened insert plate or around a reinforcing plate shall be the greater of 75 mm (3 in.) or 2<sup>1</sup>/<sub>2</sub> times the shell thickness.

500 mm (20") and 600 mm (24") shell manholes: twenty-eight 20 mm-diameter (3/4") bolts in 24 mm (7/8") holes  
 750 mm (30") and 900 mm (36") shell manholes: forty-two 20 mm-diameter (3/4") bolts in 24 mm (7/8") holes  
 (Bolt holes shall straddle the flange vertical centerline.)

Gasket (see Note 1):

500 mm (20") manhole: 635 mm (25 3/8") OD x 500 mm (20") ID x 3 mm (1/8") thickness  
 600 mm (24") manhole: 735 mm (29 3/8") OD x 600 mm (24") ID x 3 mm (1/8") thickness  
 750 mm (30") manhole: 885 mm (35 3/8") OD x 750 mm (30") ID x 3 mm (1/8") thickness  
 900 mm (36") manhole: 1035 mm (41 3/8") OD x 900 mm (36") ID x 3 mm (1/8") thickness

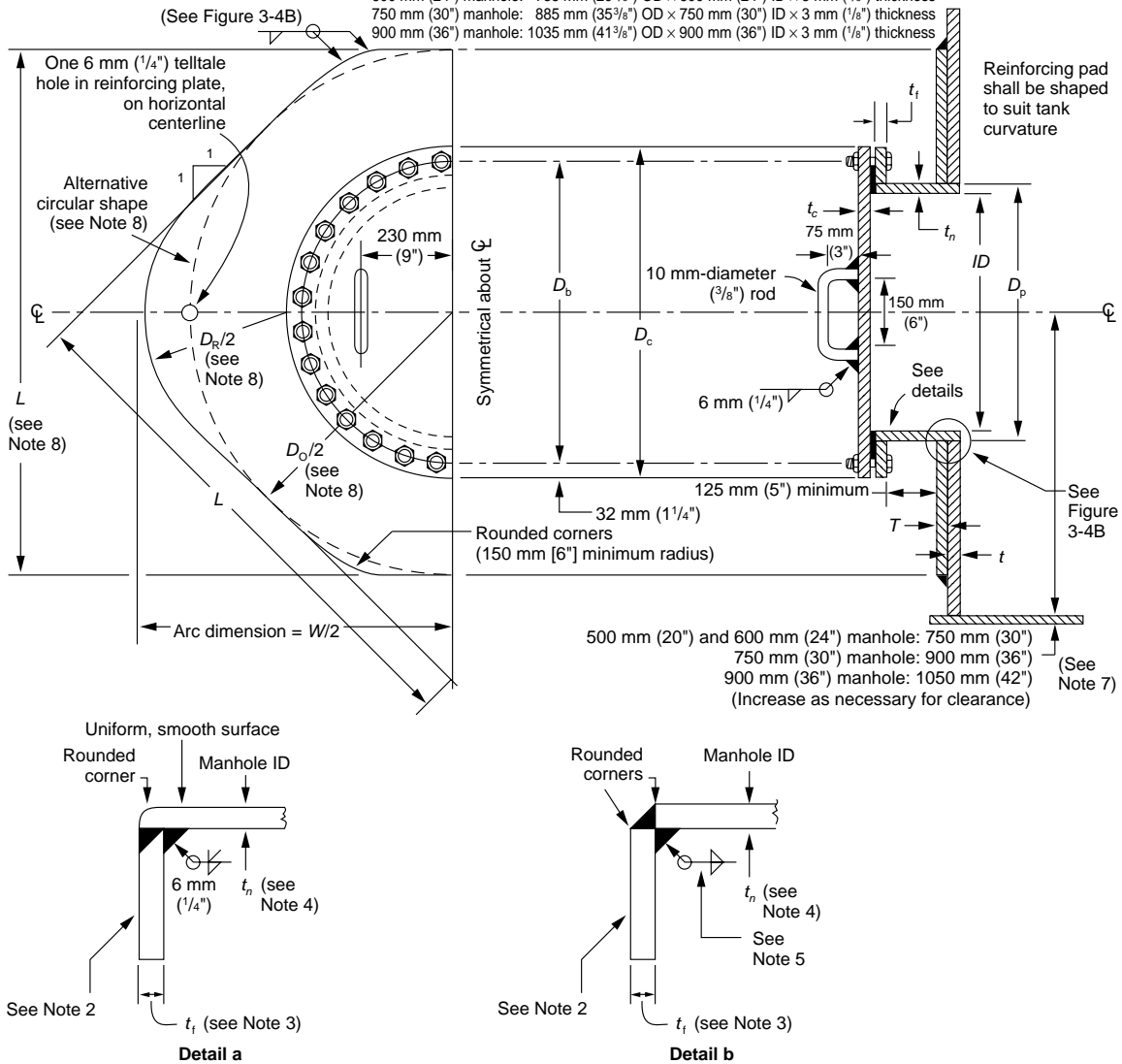

500 mm (20") and 600 mm (24") manhole: 750 mm (30")  
 750 mm (30") manhole: 900 mm (36")  
 900 mm (36") manhole: 1050 mm (42")  
 (Increase as necessary for clearance) (See Note 7)

Notes:

1. Gasket material shall be specified by the purchaser. See 3.7.5.4.
2. The gasketed face shall be machine finished to provide a minimum gasket-bearing width of 20 mm (3/4 in.).
3. See Table 3-3.
4. See Table 3-4.
5. The size of the weld shall equal the thickness of the thinner member joined.
6. The shell nozzles shown in Table 3-6 may be substituted for manholes.
7. When the shell nozzles shown in Figure 3-5 are used, the minimum centerline heights above the tank bottom given in Table 3-6 are acceptable.
8. For dimensions for  $D_o$ ,  $D_R$ ,  $L$ , and  $W$ , see Table 3-6, Columns 4, 5, and 6.

Figure 3-4A—Shell Manhole

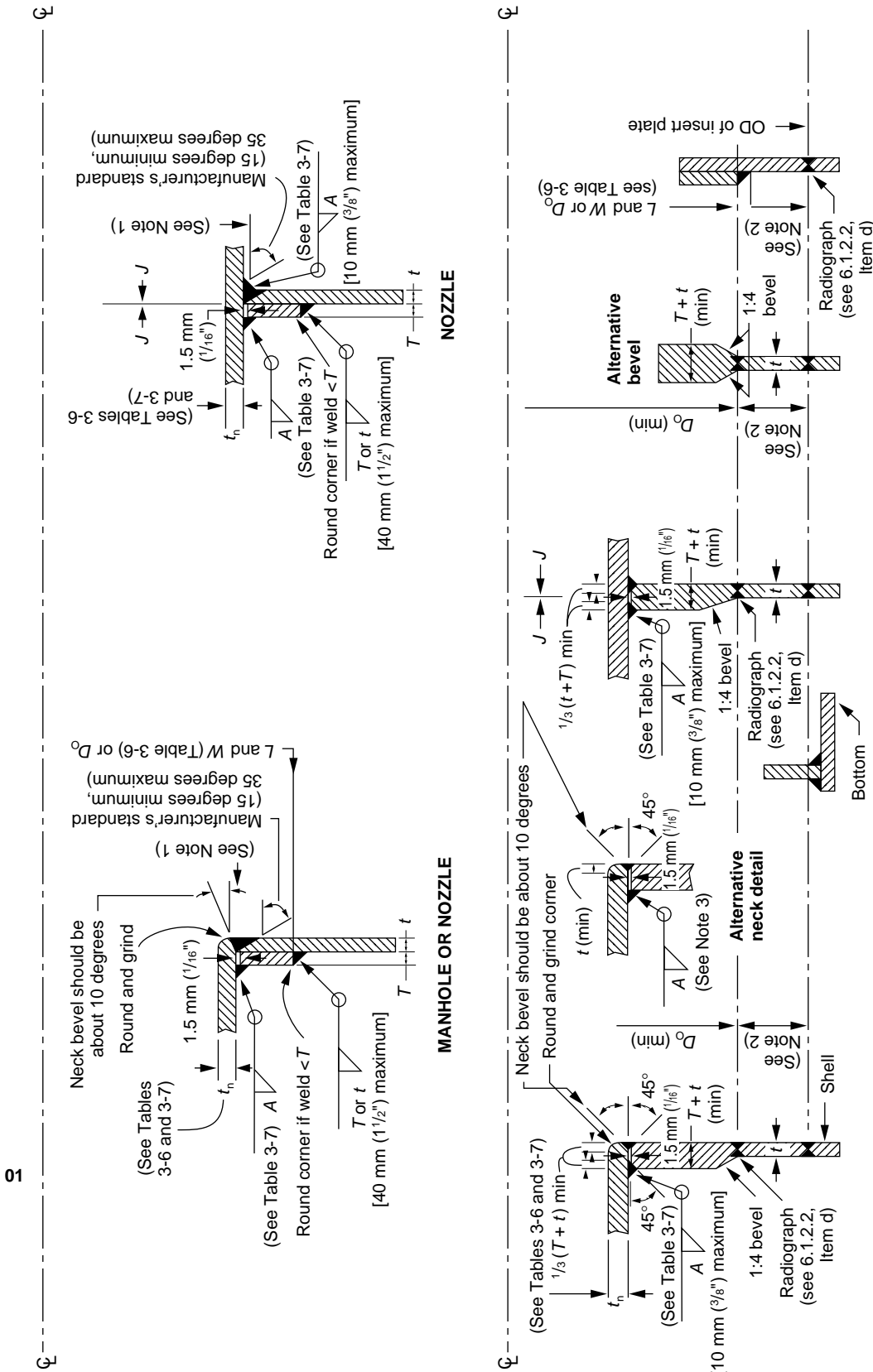

INSERT-TYPE REINFORCEMENT FOR MANHOLES AND NOZZLES

- Notes:
1. See Table 3-7, Column 3, for the shell cutout, which shall not be less than the outside diameter of the neck plus 13 mm (1/2) inch.
  2. Refer to 3.7.3 for minimum spacing of welds at opening connections.
  3. The weld size shall be either A (from Table 3-7, based on t) or t<sub>n</sub> (minimum neck thickness from Tables 3-4, 3-6, and 3-7), whichever is greater.
  4. Other permissible insert details are shown in Figure 3-8 of API Standard 620. The reinforcement area shall conform to 3.7.2.
  5. Dimensions and weld sizes that are not shown are the same as those given in Figure 3-4A and Tables 3-4 through 3-8.
  6. Details of welding bevels may vary from those shown if agreed to by the purchaser.

Figure 3-4B—Details of Shell Manholes and Nozzles

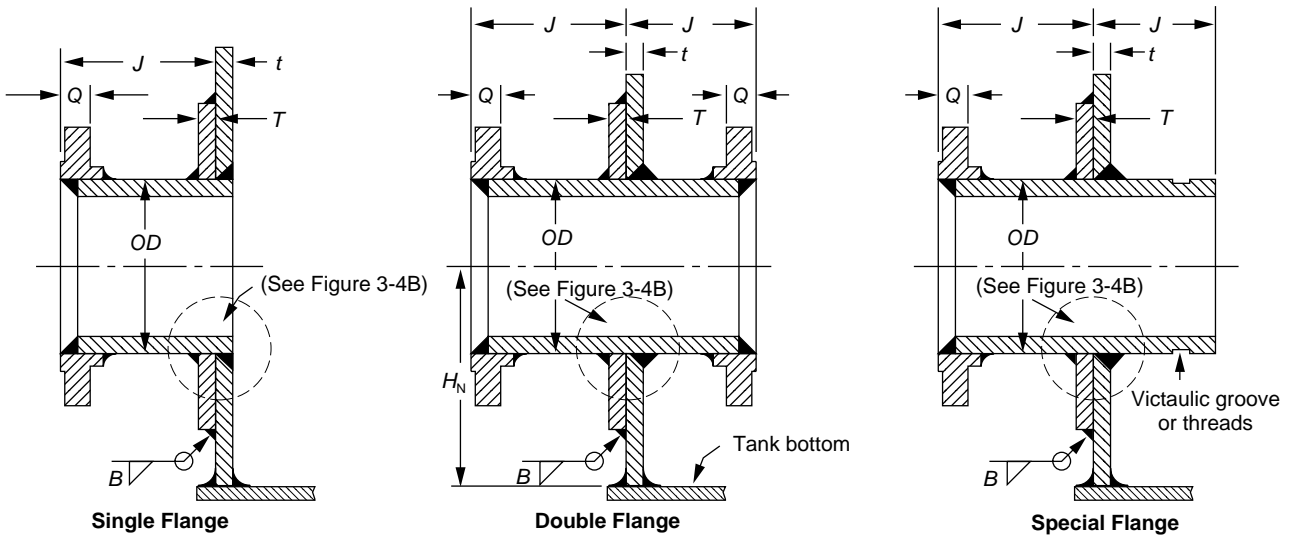
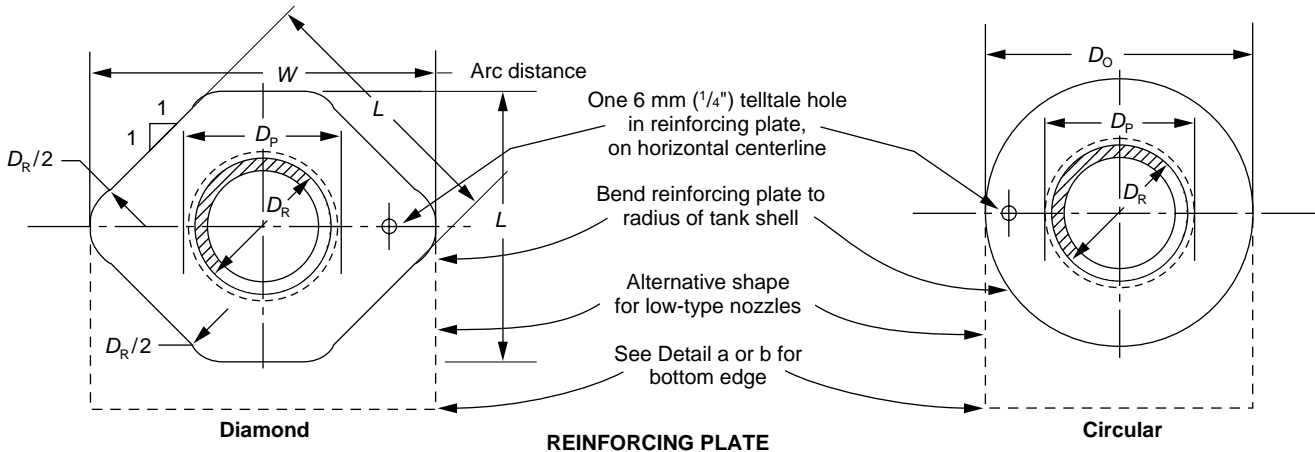

**REGULAR-TYPE FLANGED NOZZLES, NPS 3 OR LARGER**  
(Bolt holes shall straddle flange centerlines)

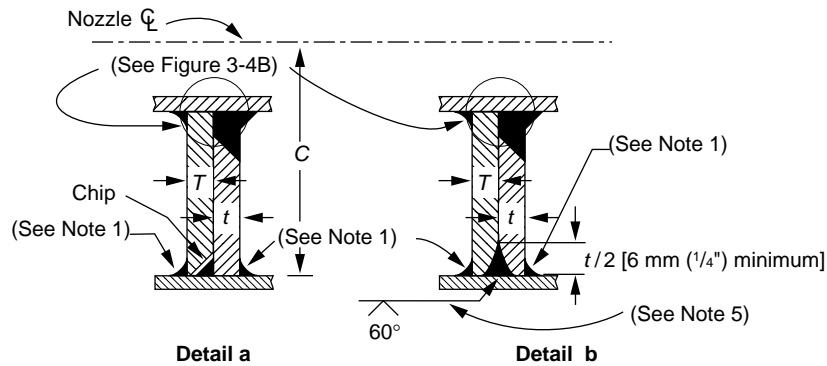

**LOW-TYPE FLANGED NOZZLES, NPS 3 OR LARGER**  
(Bolt holes shall straddle flange centerlines)

Notes:

- 1. See 3.1.5.7 for information on the size of welds.
- 2. See 3.8.8 for information on the couplings used in shell nozzles.
- 3. Nozzles NPS 3 or larger require reinforcement.
- 4. Details of welding bevels may vary from those shown if agreed to by the purchaser.
- 5. Shop weld not attached to bottom plate.

Figure 3-5—Shell Nozzles (See Tables 3-6, 3-7, and 3-8)

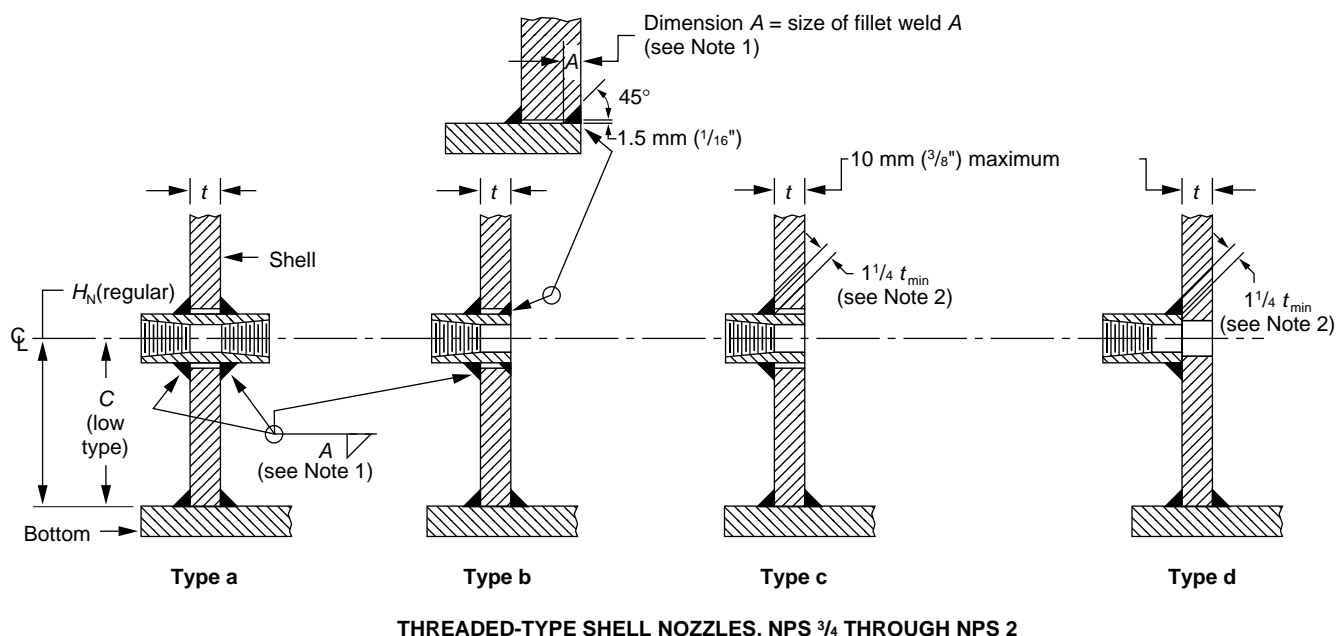

## Notes:

1. See Table 3-7, Column 6.
2.  $t_{min}$  shall be 19 mm ( $3/4$  in.) or the thickness of either part joined by the fillet weld, whichever is less.

Figure 3-5—Shell Nozzles (continued)

**3.7.3.3** The rules in 3.7.3.1 and 3.7.3.2 shall also apply to the bottom-to-shell joint unless, as an alternative, the insert plate or reinforcing plate extends to the bottom-to-shell joint and intersects it at approximately 90 degrees. A minimum distance of 75 mm (3 in.) shall be maintained between the toe of a weld around a nonreinforced penetration (see 3.7.2.1) and the toe of the shell-to-bottom weld.

- **3.7.3.4** By agreement between the purchaser and the manufacturer, circular shell openings and reinforcing plates (if used) may be located in a horizontal or vertical butt-welded shell joint provided that minimum spacing dimensions are met and a radiographic examination of the welded shell joint is conducted (see Figure 3-6, Details a, c, and e). The welded shell joint shall be 100% radiographed for a length equal to three times the diameter of the opening, but weld seam being removed need not be radiographed. Radiographic examination shall be in accordance with 6.1.3 through 6.1.8.

### 3.7.4 Thermal Stress Relief

**3.7.4.1** All flush-type cleanout fittings and flush-type shell connections shall be thermally stress-relieved after assembly prior to installation in the tank shell or after installation into the tank shell if the entire tank is stress-relieved. The stress relief shall be carried out within a temperature range of 600°C to 650°C (1100°F to 1200°F) (see 3.7.4.3 for quenched and tempered materials) for 1 hour per 25 mm (1 in.) of shell thickness. The assembly shall include the bottom reinforcing plate (or annular plate) and the flange-to-neck weld.

**3.7.4.2** When the shell material is Group I, II, III, or IIIA, all opening connections NPS 12 or larger in nominal diameter in a shell plate or thickened insert plate more than 25 mm (1 in.) thick shall be prefabricated into the shell plate or thickened insert plate, and the prefabricated assembly shall be thermally stress-relieved within a temperature range of 600°C to 650°C (1100°F to 1200°F) for 1 hour per 25 mm (1 in.) of thickness prior to installation. The stress-relieving requirements need not include the flange-to-neck welds or other nozzle-neck and manhole-neck attachments, provided the following conditions are fulfilled:

- a. The welds are outside the reinforcement (see 3.7.2.3).
- b. The throat dimension of a fillet weld in a slip-on flange does not exceed 16 mm ( $5/8$  in.), or the butt joint of a welding-neck flange does not exceed 19 mm ( $3/4$  in.). If the material is preheated to a minimum temperature of 90°C (200°F) during welding, the weld limits of 16 mm ( $5/8$  in.) and 19 mm ( $3/4$  in.) may be increased to 32 mm and 38 mm (1 $1/4$  in. and 1 $1/2$  in.), respectively.

**3.7.4.3** When the shell material is Group IV, IVA, V, or VI, all opening connections requiring reinforcement in a shell plate or thickened insert plate more than 12.5 mm ( $1/2$  in.) thick shall be prefabricated into the shell plate or thickened insert plate, and the prefabricated assembly shall be thermally stress relieved within a temperature range of 600°C to 650°C (1100°F to 1200°F) for 1 hour per 25 mm (1 in.) of thickness prior to installation.

Table 3-6—Dimensions for Shell Nozzles [mm (in.)]

Column 1	Column 2	Column 3	Column 4	Column 5	Column 6	Column 7 <sup>c</sup>	Column 8 <sup>c</sup>	Column 9 <sup>c</sup>
NPS (Size of Nozzle)	Outside Diameter of Pipe	Nominal Thickness of Flanged Nozzle Pipe Wall <sup>a,b</sup> <i>t<sub>n</sub></i>	Diameter of Hole in Reinforcing Plate <i>D<sub>R</sub></i>	Length of Side of Reinforcing Plate <sup>b</sup> or Diameter <i>L = D<sub>o</sub></i>	Width of Reinforcing Plate <i>W</i>	Minimum Distance from Shell to Flange Face <i>J</i>	Minimum Distance from Bottom of Tank to Center of Nozzle Regular Type <sup>d</sup> <i>H<sub>N</sub></i>	Low Type <i>C</i>
Flanged Fittings								
48	1219.2 (48)	e	1222 (48 <sup>1</sup> / <sub>8</sub> )	2455 (96 <sup>3</sup> / <sub>4</sub> )	2970 (117)	400 (16)	1325 (52)	1230 (48 <sup>3</sup> / <sub>8</sub> )
46	1168.4 (46)	e	1172 (46 <sup>1</sup> / <sub>8</sub> )	2355 (92 <sup>3</sup> / <sub>4</sub> )	2845 (112)	400 (16)	1275 (50)	1180 (46 <sup>3</sup> / <sub>8</sub> )
44	1117.6 (44)	e	1121 (44 <sup>1</sup> / <sub>8</sub> )	2255 (88 <sup>3</sup> / <sub>4</sub> )	2725 (107 <sup>1</sup> / <sub>4</sub> )	375 (15)	1225 (48)	1125 (44 <sup>3</sup> / <sub>8</sub> )
42	1066.8 (42)	e	1070 (42 <sup>1</sup> / <sub>8</sub> )	2155 (84 <sup>3</sup> / <sub>4</sub> )	2605 (102 <sup>1</sup> / <sub>2</sub> )	375 (15)	1175 (46)	1075 (42 <sup>3</sup> / <sub>8</sub> )
40	1016 (40)	e	1019 (40 <sup>1</sup> / <sub>8</sub> )	2050 (80 <sup>3</sup> / <sub>4</sub> )	2485 (97 <sup>3</sup> / <sub>4</sub> )	375 (15)	1125 (44)	1025 (40 <sup>3</sup> / <sub>8</sub> )
38	965.2 (38)	e	968 (38 <sup>1</sup> / <sub>8</sub> )	1950 (76 <sup>3</sup> / <sub>4</sub> )	2355 (92 <sup>3</sup> / <sub>4</sub> )	350 (14)	1075 (42)	975 (38 <sup>3</sup> / <sub>8</sub> )
36	914.4 (36)	e	918 (36 <sup>1</sup> / <sub>8</sub> )	1850 (72 <sup>3</sup> / <sub>4</sub> )	2235 (88)	350 (14)	1025 (40)	925 (36 <sup>3</sup> / <sub>8</sub> )
34	863.6 (34)	e	867 (34 <sup>1</sup> / <sub>8</sub> )	1745 (68 <sup>3</sup> / <sub>4</sub> )	2115 (83 <sup>1</sup> / <sub>4</sub> )	325 (13)	975 (38)	875 (34 <sup>3</sup> / <sub>8</sub> )
32	812.8 (32)	e	816 (32 <sup>1</sup> / <sub>8</sub> )	1645 (64 <sup>3</sup> / <sub>4</sub> )	1995 (78 <sup>1</sup> / <sub>2</sub> )	325 (13)	925 (36)	820 (32 <sup>3</sup> / <sub>8</sub> )
30	762.0 (30)	e	765 (30 <sup>1</sup> / <sub>8</sub> )	1545 (60 <sup>3</sup> / <sub>4</sub> )	1865 (73 <sup>1</sup> / <sub>2</sub> )	300 (12)	875 (34)	770 (30 <sup>3</sup> / <sub>8</sub> )
28	711.2 (28)	e	714 (28 <sup>1</sup> / <sub>8</sub> )	1440 (56 <sup>3</sup> / <sub>4</sub> )	1745 (68 <sup>3</sup> / <sub>4</sub> )	300 (12)	825 (32)	720 (28 <sup>3</sup> / <sub>8</sub> )
26	660.4 (26)	e	664 (26 <sup>1</sup> / <sub>8</sub> )	1340 (52 <sup>3</sup> / <sub>4</sub> )	1625 (64)	300 (12)	750 (30)	670 (26 <sup>3</sup> / <sub>8</sub> )
24	609.6 (24)	12.7 (0.50)	613 (24 <sup>1</sup> / <sub>8</sub> )	1255 (49 <sup>1</sup> / <sub>2</sub> )	1525 (60)	300 (12)	700 (28)	630 (24 <sup>3</sup> / <sub>4</sub> )
22	558.8 (22)	12.7 (0.50)	562 (22 <sup>1</sup> / <sub>8</sub> )	1155 (45 <sup>1</sup> / <sub>2</sub> )	1405 (55 <sup>1</sup> / <sub>4</sub> )	275 (11)	650 (26)	580 (22 <sup>3</sup> / <sub>4</sub> )
20	508.0 (20)	12.7 (0.50)	511 (20 <sup>1</sup> / <sub>8</sub> )	1055 (41 <sup>1</sup> / <sub>2</sub> )	1285 (50 <sup>1</sup> / <sub>2</sub> )	275 (11)	600 (24)	525 (20 <sup>3</sup> / <sub>4</sub> )
18	457.2 (18)	12.7 (0.50)	460 (18 <sup>1</sup> / <sub>8</sub> )	950 (37 <sup>1</sup> / <sub>2</sub> )	1160 (45 <sup>3</sup> / <sub>4</sub> )	250 (10)	550 (22)	475 (18 <sup>3</sup> / <sub>4</sub> )
16	406.4 (16)	12.7 (0.50)	410 (16 <sup>1</sup> / <sub>8</sub> )	850 (33 <sup>1</sup> / <sub>2</sub> )	1035 (40 <sup>3</sup> / <sub>4</sub> )	250 (10)	500 (20)	425 (16 <sup>3</sup> / <sub>4</sub> )
14	355.6 (14)	12.7 (0.50)	359 (14 <sup>1</sup> / <sub>8</sub> )	750 (29 <sup>1</sup> / <sub>2</sub> )	915 (36)	250 (10)	450 (18)	375 (14 <sup>3</sup> / <sub>4</sub> )
12	323.8 (12 <sup>3</sup> / <sub>4</sub> )	12.7 (0.50)	327 (12 <sup>7</sup> / <sub>8</sub> )	685 (27)	840 (33)	225 (9)	425 (17)	345 (13 <sup>1</sup> / <sub>2</sub> )
10	273.0 (10 <sup>3</sup> / <sub>4</sub> )	12.7 (0.50)	276 (10 <sup>7</sup> / <sub>8</sub> )	585 (23)	720 (28 <sup>1</sup> / <sub>4</sub> )	225 (9)	375 (15)	290 (11 <sup>1</sup> / <sub>2</sub> )
8	219.1 (8 <sup>5</sup> / <sub>8</sub> )	12.7 (0.50)	222 (8 <sup>3</sup> / <sub>4</sub> )	485 (19)	590 (23 <sup>1</sup> / <sub>4</sub> )	200 (8)	325 (13)	240 (9 <sup>1</sup> / <sub>2</sub> )
6	168.3 (6 <sup>5</sup> / <sub>8</sub> )	10.97 (0.432)	171 (6 <sup>3</sup> / <sub>4</sub> )	400 (15 <sup>3</sup> / <sub>4</sub> )	495 (19 <sup>1</sup> / <sub>2</sub> )	200 (8)	275 (11)	200 (7 <sup>7</sup> / <sub>8</sub> )
4	114.3 (4 <sup>1</sup> / <sub>2</sub> )	8.56 (0.337)	117 (4 <sup>5</sup> / <sub>8</sub> )	305 (12)	385 (15 <sup>1</sup> / <sub>4</sub> )	175 (7)	225 (9)	150 (6)
3	88.9 (3 <sup>1</sup> / <sub>2</sub> )	7.62 (0.300)	92 (3 <sup>5</sup> / <sub>8</sub> )	265 (10 <sup>1</sup> / <sub>2</sub> )	345 (13 <sup>1</sup> / <sub>2</sub> )	175 (7)	200 (8)	135 (5 <sup>1</sup> / <sub>4</sub> )
2 <sup>f</sup>	60.3 (2 <sup>3</sup> / <sub>8</sub> )	5.54 (0.218)	63 (2 <sup>1</sup> / <sub>2</sub> )	—	—	150 (6)	175 (7)	i
1 <sup>1</sup> / <sub>2</sub> <sup>f</sup>	48.3 (1.90)	5.08 (0.200)	51 (2)	—	—	150 (6)	150 (6)	i
Threaded Fittings								
3 <sup>g</sup>	108.0 (4.250)	Coupling	111.1 (4 <sup>3</sup> / <sub>8</sub> )	285 (11 <sup>1</sup> / <sub>4</sub> )	360 (14 <sup>1</sup> / <sub>4</sub> )	—	225 (9)	145 (5 <sup>5</sup> / <sub>8</sub> )
2 <sup>f</sup>	76.2 (3.000)	Coupling	79.4 (3 <sup>1</sup> / <sub>8</sub> )	—	—	—	175 (7)	i
31 <sup>1</sup> / <sub>2</sub> <sup>f</sup>	63.5 (2.500)	Coupling	66.7 (2 <sup>5</sup> / <sub>8</sub> )	—	—	—	150 (6)	i
1 <sup>f</sup>	44.5 (1.750)	Coupling	47.6 (1 <sup>7</sup> / <sub>8</sub> )	—	—	—	125 (5)	i
3/4 <sup>f</sup>	35.0 (1.375)	Coupling	38.1 (1 <sup>1</sup> / <sub>2</sub> )	—	—	—	100 (4)	i

<sup>a</sup>For extra-strong pipe, refer to ASTM A 53 or A 106 for other wall thicknesses; however, piping material must conform to 2.5.

<sup>b</sup>The width of the shell plate shall be sufficient to contain the reinforcing plate and to provide clearance from the girth joint of the shell course.

● <sup>c</sup>Unless otherwise specified by the purchaser, the nozzle shall be located at the minimum distance but shall also meet the weld spacing requirements of 3.7.3.

<sup>d</sup>The *H<sub>N</sub>* dimensions given in this table are for Appendix A tank designs only; refer to 3.7.3 to determine minimum *H<sub>N</sub>* for basic tank designs.

<sup>e</sup>See Table 3-7, Column 2.

<sup>f</sup>Flanged nozzles and threaded nozzles in pipe sizes NPS 2 or smaller do not require reinforcing plates. *D<sub>R</sub>* will be the diameter of the hole in the shell plate, and Weld A will be as specified in Table 3-7, Column 6. Reinforcing plates may be used if desired.

<sup>g</sup>A threaded nozzle in an NPS 3 requires reinforcement.

● <sup>h</sup>Any specified corrosion allowance shall, by agreement between the purchaser and the manufacturer, be added to either the nominal thickness shown or the minimum calculated thickness required for pressure head and mechanical strength. In no case shall the thickness provided be less than the nominal thickness shown.

<sup>i</sup>Refer to 3.7.3.

Note: See Figure 3-5.

01

00

Table 3-7—Dimensions for Shell Nozzles: Pipe, Plate, and Welding Schedules [mm (in.)]

Column 1 Thickness of Shell and Reinforcing Plate <sup>a</sup> <i>t</i> and <i>T</i>	Column 2 Minimum Pipe Wall Thickness of Flanged Nozzles <sup>b,c</sup> <i>t<sub>n</sub></i>	Column 3 Maximum Diameter of Hole in Shell Plate ( <i>D<sub>p</sub></i> ) Equals Outside Diameter of Pipe Plus	Column 4 Size of Fillet Weld <i>B</i>	Column 5 Size of Fillet Weld <i>A</i>		Column 6 NPS 2, 1 <sup>1</sup> / <sub>2</sub> , 1 <sup>3</sup> / <sub>4</sub> Nozzles
				Nozzles Larger Than NPS 2		
5 (3/16)	12.5 (1/2)	16 (5/8)	5 (3/16)	6 (1/4)	6 (1/4)	
6 (1/4)	12.5 (1/2)	16 (5/8)	6 (1/4)	6 (1/4)	6 (1/4)	
8 (5/16)	12.5 (1/2)	16 (5/8)	8 (5/16)	6 (1/4)	6 (1/4)	
10 (3/8)	12.5 (1/2)	16 (5/8)	10 (3/8)	6 (1/4)	6 (1/4)	
11 (7/16)	12.5 (1/2)	16 (5/8)	11 (7/16)	6 (1/4)	6 (1/4)	
12.5 (1/2)	12.5 (1/2)	16 (5/8)	13 (1/2)	6 (1/4)	8 (5/16)	
14 (9/16)	12.5 (1/2)	20 (3/4)	14 (9/16)	6 (1/4)	8 (5/16)	
16 (5/8)	12.5 (1/2)	20 (3/4)	16 (5/8)	8 (5/16)	8 (5/16)	
17 (11/16)	12.5 (1/2)	20 (3/4)	18 (11/16)	8 (5/16)	8 (5/16)	
20 (3/4)	12.5 (1/2)	20 (3/4)	20 (3/4)	8 (5/16)	8 (5/16)	
21 (13/16)	12.5 (1/2)	20 (3/4)	21 (13/16)	10 (3/8)	8 (5/16)	
22 (7/8)	12.5 (1/2)	20 (3/4)	22 (7/8)	10 (3/8)	8 (5/16)	
24 (15/16)	12.5 (1/2)	20 (3/4)	24 (15/16)	10 (3/8)	8 (5/16)	
25 (1)	12.5 (1/2)	20 (3/4)	25 (1)	11 (7/16)	8 (5/16)	
27 (11/16)	14 (9/16)	20 (3/4)	27 (11/16)	11 (7/16)	8 (5/16)	
28 (11/8)	14 (9/16)	20 (3/4)	28 (11/8)	11 (7/16)	8 (5/16)	
30 (13/16)	16 (5/8)	20 (3/4)	30 (13/16)	13 (1/2)	8 (5/16)	
32 (11/4)	16 (5/8)	20 (3/4)	32 (11/4)	13 (1/2)	8 (5/16)	
33 (15/16)	17 (11/16)	20 (3/4)	33 (15/16)	13 (1/2)	8 (5/16)	
35 (13/8)	17 (11/16)	20 (3/4)	35 (13/8)	14 (9/16)	8 (5/16)	
36 (17/16)	20 (3/4)	20 (3/4)	36 (17/16)	14 (9/16)	8 (5/16)	
38 (11/2)	20 (3/4)	20 (3/4)	38 (11/2)	14 (9/16)	8 (5/16)	
40 (19/16)	21 (13/16)	20 (3/4)	38 (11/2)	14 (9/16)	8 (5/16)	
41 (15/8)	21 (13/16)	20 (3/4)	38 (11/2)	16 (5/8)	8 (5/16)	
43 (111/16)	22 (7/8)	20 (3/4)	38 (11/2)	16 (5/8)	8 (5/16)	
45 (13/4)	22 (7/8)	20 (3/4)	38 (11/2)	16 (5/8)	8 (5/16)	

<sup>a</sup>If a shell plate thicker than required is used for the product and hydrostatic loading (see 3.6), the excess shell-plate thickness, within a vertical distance both above and below the centerline of the hole in the tank shell plate equal to the vertical dimension of the hole in the tank shell plate, may be considered as reinforcement, and the thickness *T* of the nozzle reinforcing plate may be decreased accordingly. In such cases, the reinforcement and the attachment welding shall conform to the design limits for reinforcement of shell openings specified in 3.7.2.

<sup>b</sup>This column applies to NPS 48, 46, 44, 42, 40, 38, 36, 34, 32, 30, 28, and 26 flanged nozzles. Refer to 2.5 for piping materials.

- <sup>c</sup>Any specified corrosion allowance shall, by agreement between the purchaser and the manufacturer, be added to either the minimum thickness shown or to the minimum calculated thickness required for pressure head and mechanical strength. In no case shall the thickness provided be less than the minimum thickness shown.

Note: See Figure 3-5.

Table 3-8—Dimensions for Shell Nozzle Flanges [mm (in.)]

Column 1	Column 2	Column 3	Column 4	Column 5	Column 6	Column 7	Column 8	Diameter of Bore		Minimum Diameter of Hub at Point of Weld	
								Slip-on Type: Outside Diameter of Pipe Plus <i>B</i>	Welding Neck Type <sup>a</sup> <i>B</i> <sub>1</sub>	Slip-on Type <sup>b</sup> <i>E</i>	Welding- Neck Type <sup>c</sup> <i>E</i> <sub>1</sub>
48	70 (2 <sup>3</sup> / <sub>4</sub> )	1510 (59 <sup>1</sup> / <sub>2</sub> )	1360 (53 <sup>1</sup> / <sub>2</sub> )	1420 (56)	44 (44)	42 (1 <sup>5</sup> / <sub>8</sub> )	38 (1 <sup>1</sup> / <sub>2</sub> )	6.8 (0.25)	a	b	c
46	68 (2 <sup>11</sup> / <sub>16</sub> )	1460 (57 <sup>1</sup> / <sub>2</sub> )	1295 (51)	1365 (53 <sup>3</sup> / <sub>4</sub> )	40 (40)	42 (1 <sup>5</sup> / <sub>8</sub> )	38 (1 <sup>1</sup> / <sub>2</sub> )	6.6 (0.25)	a	b	c
44	67 (2 <sup>5</sup> / <sub>8</sub> )	1405 (55 <sup>1</sup> / <sub>4</sub> )	1245 (49)	1315 (51 <sup>3</sup> / <sub>4</sub> )	40 (40)	42 (1 <sup>5</sup> / <sub>8</sub> )	38 (1 <sup>1</sup> / <sub>2</sub> )	6.4 (0.25)	a	b	c
42	67 (2 <sup>5</sup> / <sub>8</sub> )	1345 (53)	1195 (47)	1255 (49 <sup>1</sup> / <sub>2</sub> )	36 (36)	42 (1 <sup>5</sup> / <sub>8</sub> )	38 (1 <sup>1</sup> / <sub>2</sub> )	6.2 (0.25)	a	b	c
40	65 (2 <sup>1</sup> / <sub>2</sub> )	1290 (50 <sup>3</sup> / <sub>4</sub> )	1125 (44 <sup>1</sup> / <sub>4</sub> )	1200 (47 <sup>1</sup> / <sub>4</sub> )	36 (36)	42 (1 <sup>5</sup> / <sub>8</sub> )	38 (1 <sup>1</sup> / <sub>2</sub> )	6.0 (0.25)	a	b	c
38	60 (2 <sup>3</sup> / <sub>8</sub> )	1240 (48 <sup>3</sup> / <sub>4</sub> )	1075 (42 <sup>1</sup> / <sub>4</sub> )	1150 (45 <sup>1</sup> / <sub>4</sub> )	32 (32)	42 (1 <sup>5</sup> / <sub>8</sub> )	38 (1 <sup>1</sup> / <sub>2</sub> )	6.8 (0.25)	a	b	c
36	60 (2 <sup>3</sup> / <sub>8</sub> )	1170 (46)	1020 (40 <sup>1</sup> / <sub>4</sub> )	1085 (42 <sup>3</sup> / <sub>4</sub> )	32 (32)	42 (1 <sup>5</sup> / <sub>8</sub> )	38 (1 <sup>1</sup> / <sub>2</sub> )	6.6 (0.25)	a	b	c
34	59 (2 <sup>5</sup> / <sub>16</sub> )	1110 (43 <sup>3</sup> / <sub>4</sub> )	960 (37 <sup>3</sup> / <sub>4</sub> )	1030 (40 <sup>1</sup> / <sub>2</sub> )	32 (32)	42 (1 <sup>5</sup> / <sub>8</sub> )	38 (1 <sup>1</sup> / <sub>2</sub> )	6.4 (0.25)	a	b	c
32	57 (2 <sup>1</sup> / <sub>4</sub> )	1060 (41 <sup>3</sup> / <sub>4</sub> )	910 (35 <sup>3</sup> / <sub>4</sub> )	980 (38 <sup>1</sup> / <sub>2</sub> )	28 (28)	42 (1 <sup>5</sup> / <sub>8</sub> )	38 (1 <sup>1</sup> / <sub>2</sub> )	6.2 (0.25)	a	b	c
30	54 (2 <sup>1</sup> / <sub>8</sub> )	985 (38 <sup>3</sup> / <sub>4</sub> )	855 (33 <sup>3</sup> / <sub>4</sub> )	915 (36)	28 (28)	33 (1 <sup>3</sup> / <sub>8</sub> )	30 (1 <sup>1</sup> / <sub>4</sub> )	6.0 (0.25)	a	b	c
28	52 (2 <sup>1</sup> / <sub>16</sub> )	925 (36 <sup>1</sup> / <sub>2</sub> )	795 (31 <sup>1</sup> / <sub>4</sub> )	865 (34)	28 (28)	33 (1 <sup>3</sup> / <sub>8</sub> )	30 (1 <sup>1</sup> / <sub>4</sub> )	6.8 (0.25)	a	b	c
26	50 (2)	870 (34 <sup>1</sup> / <sub>4</sub> )	745 (29 <sup>1</sup> / <sub>4</sub> )	805 (31 <sup>3</sup> / <sub>4</sub> )	24 (24)	33 (1 <sup>3</sup> / <sub>8</sub> )	30 (1 <sup>1</sup> / <sub>4</sub> )	6.6 (0.25)	a	b	c
24	48 (1 <sup>7</sup> / <sub>8</sub> )	815 (32)	690 (27 <sup>1</sup> / <sub>4</sub> )	750 (29 <sup>1</sup> / <sub>2</sub> )	20 (20)	33 (1 <sup>3</sup> / <sub>8</sub> )	30 (1 <sup>1</sup> / <sub>4</sub> )	4.4 (0.19)	a	b	c
22	46 (1 <sup>13</sup> / <sub>16</sub> )	750 (29 <sup>1</sup> / <sub>2</sub> )	640 (25 <sup>1</sup> / <sub>4</sub> )	690 (27 <sup>1</sup> / <sub>4</sub> )	20 (20)	33 (1 <sup>3</sup> / <sub>8</sub> )	30 (1 <sup>1</sup> / <sub>4</sub> )	5.2 (0.19)	a	b	c
20	43 (1 <sup>11</sup> / <sub>16</sub> )	700 (27 <sup>1</sup> / <sub>2</sub> )	585 (23)	635 (25)	20 (20)	30 (1 <sup>1</sup> / <sub>4</sub> )	27 (1 <sup>1</sup> / <sub>8</sub> )	5.0 (0.19)	a	b	c
18	40 (1 <sup>9</sup> / <sub>16</sub> )	635 (25)	535 (21)	580 (22 <sup>3</sup> / <sub>4</sub> )	16 (16)	30 (1 <sup>1</sup> / <sub>4</sub> )	27 (1 <sup>1</sup> / <sub>8</sub> )	4.8 (0.19)	a	b	c
16	36 (1 <sup>7</sup> / <sub>16</sub> )	595 (23 <sup>1</sup> / <sub>2</sub> )	470 (18 <sup>1</sup> / <sub>2</sub> )	540 (21 <sup>1</sup> / <sub>4</sub> )	16 (16)	27 (1 <sup>1</sup> / <sub>8</sub> )	24 (1)	4.6 (0.19)	a	b	c
14	35 (1 <sup>3</sup> / <sub>8</sub> )	535 (21)	415 (16 <sup>1</sup> / <sub>4</sub> )	475 (18 <sup>3</sup> / <sub>4</sub> )	12 (12)	27 (1 <sup>1</sup> / <sub>8</sub> )	24 (1)	4.4 (0.19)	a	b	c
12	32 (1 <sup>1</sup> / <sub>4</sub> )	485 (19)	380 (15)	430 (17)	12 (12)	25 (1)	22 (7/8)	3.15 (0.13)	a	b	c
10	30 (1 <sup>3</sup> / <sub>16</sub> )	405 (16)	325 (12 <sup>3</sup> / <sub>4</sub> )	360 (14 <sup>1</sup> / <sub>4</sub> )	12 (12)	25 (1)	22 (7/8)	2.95 (0.13)	a	b	c
8	28 (1 <sup>1</sup> / <sub>8</sub> )	345 (13 <sup>1</sup> / <sub>2</sub> )	270 (10 <sup>5</sup> / <sub>8</sub> )	300 (11 <sup>3</sup> / <sub>4</sub> )	8 (8)	23 (7/8)	20 (3/4)	2.92 (0.10)	a	b	c
6	25 (1)	280 (11)	216 (8 <sup>1</sup> / <sub>2</sub> )	240 (9 <sup>1</sup> / <sub>2</sub> )	8 (8)	23 (7/8)	20 (3/4)	2.72 (0.10)	a	b	c
4	24 (1 <sup>5</sup> / <sub>16</sub> )	230 (9)	157 (6 <sup>3</sup> / <sub>16</sub> )	190 (7 <sup>1</sup> / <sub>2</sub> )	8 (8)	19 (3/4)	16 (5/8)	1.7 (0.06)	a	b	c
3	24 (1 <sup>5</sup> / <sub>16</sub> )	190 (7 <sup>1</sup> / <sub>2</sub> )	127 (5)	152 (6)	4 (4)	19 (3/4)	16 (5/8)	1.1 (0.06)	a	b	c
2	20 (3/4)	150 (6)	92 (3 <sup>5</sup> / <sub>8</sub> )	121 (4 <sup>3</sup> / <sub>4</sub> )	4 (4)	19 (3/4)	16 (5/8)	1.68 (0.07)	a	b	c
1 <sup>1</sup> / <sub>2</sub>	17 (1 <sup>1</sup> / <sub>16</sub> )	125 (5)	73 (2 <sup>7</sup> / <sub>8</sub> )	98 (3 <sup>7</sup> / <sub>8</sub> )	4 (4)	16 (5/8)	12 (1/2)	1.74 (0.07)	a	b	c

<sup>a</sup>*B*<sub>1</sub> = inside diameter of pipe.<sup>b</sup>*E* = outside diameter of pipe + 2*t<sub>n</sub>*.<sup>c</sup>*E*<sub>1</sub> = outside diameter of pipe.<sup>d</sup>Corrosion allowance, if specified, need not be added to flange and cover thicknesses complying with ASME B16.5 Class 150, ASME B16.1 Class 125, and ASME B16.47 flanges.Note: See Figure 3-7. The facing dimensions for slip-on and welding-neck flanges in NPS 1<sup>1</sup>/<sub>2</sub> through 20 and NPS 24 are identical to those specified in ASME B16.5 for Class 150 steel flanges. The facing dimensions for flanges in NPS 30, 36, 42, and 48 are in agreement with ASME B16.1 for Class 125 cast iron flanges. The dimensions for large flanges may conform to Series B of ASME B16.47.

Table 3-9—Dimensions for Flush-Type Cleanout Fittings [mm (in.)]

Column 1	Column 2	Column 3	Column 4	Column 5	Column 6	Column 7	Column 8	Column 9	Column 10	Column 11
Height of Opening $h$	Width of Opening $b$	Arc Width of Shell Reinforcing Plate $W$	Upper Corner Radius of Opening $r_1$	Upper Corner Radius of Shell Reinforcing Plate $r_2$	Edge Distance of Bolts $e$	Flange Width <sup>a</sup> (Except at Bottom) $f_3$	Bottom Flange Width $f_2$	Special Bolt Spacing <sup>b</sup> $g$	Number of Bolts	Diameter of Bolts
200 (8)	400 (16)	1170 (46)	100 (4)	360 (14)	32 (1 <sup>1</sup> / <sub>4</sub> )	100 (4)	90 (3 <sup>1</sup> / <sub>2</sub> )	80 (3 <sup>1</sup> / <sub>4</sub> )	22	20 (3 <sup>3</sup> / <sub>4</sub> )
600 (24)	600 (24)	1830 (72)	300 (12)	740 (29)	40 (1 <sup>1</sup> / <sub>2</sub> )	100 (4)	95 (3 <sup>3</sup> / <sub>4</sub> )	90 (3 <sup>1</sup> / <sub>2</sub> )	36	20 (3 <sup>3</sup> / <sub>4</sub> )
900 (36)	1200 (48)	2700 (106)	450 <sup>c</sup> (18)	1040 (41)	40 (1 <sup>1</sup> / <sub>2</sub> )	115 (4 <sup>1</sup> / <sub>2</sub> )	120 (4 <sup>3</sup> / <sub>4</sub> )	110 (4 <sup>1</sup> / <sub>4</sub> )	46	24 (1)
1200 <sup>d</sup> (48)	1200 (48)	3200 (125)	600 (24)	1310 (51 <sup>1</sup> / <sub>2</sub> )	40 (1 <sup>1</sup> / <sub>2</sub> )	115 (4 <sup>1</sup> / <sub>2</sub> )	125 (5)	115 (4 <sup>1</sup> / <sub>2</sub> )	52	24 (1)

<sup>a</sup>For neck thicknesses greater than 40 mm (1<sup>9</sup>/<sub>16</sub> in.), increase  $f_3$  as necessary to provide a 1.5 mm (1<sup>1</sup>/<sub>16</sub> in.) clearance between the required neck-to-flange weld and the head of the bolt.

<sup>b</sup>Refers to spacing at the lower corners of the cleanout-fitting flange.

● <sup>c</sup>For Groups IV, IVA, V, and VI, 600 mm (24 in.).

<sup>d</sup>Only for Group I, II, III, or IIIA shell materials (see 3.7.7.2).

Note: See Figure 3-9.

When connections are installed in quenched and tempered material, the maximum thermal stress-relieving temperature shall not exceed the tempering temperature for the materials in the prefabricated stress-relieving assembly. The stress-relieving requirements do not apply to the weld to the bottom annular plate, but they do apply to flush-type cleanout openings when the bottom reinforcing plate is an annular-plate section. The stress-relieving requirements need not include the flange-to-neck welds or other nozzle-neck and manhole-neck attachments, provided the conditions of 3.7.4.2 are fulfilled.

**3.7.4.4** Inspection after stress relief shall be in accordance with 5.2.3.6.

- **3.7.4.5** When it is impractical to stress relieve at a minimum temperature of 600°C (1100°F), it is permissible, subject to the purchaser's agreement, to carry out the stress-relieving operation at lower temperatures for longer periods of time in accordance with the following tabulation:

Minimum Stress-Relieving Temperature		Holding Time [hours per 25 mm (1 in.) of thickness]	See Note
(°C)	(°F)		
600	1100	1	1
570	1050	2	1
540	1000	4	1
510	950	10	1, 2
480 (min.)	900 (min.)	20	1, 2

Notes:

- For intermediate temperatures, the time of heating shall be determined by straight line interpolation.
- Stress relieving at these temperatures is not permitted for A 537, class 2 material.

**3.7.4.6** When used in stress-relieved assemblies, the material of quenched and tempered steels A 537, C1 2 and A 678, Grade B, and of TMCP steel A 841 shall be represented by test specimens that have been subjected to the same heat treatment as that used for the stress relieved assembly.

### 3.7.5 Shell Manholes

**3.7.5.1** Shell manholes shall conform to Figures 3-4A and 3-4B and Tables 3-3 through 3-5 (or Tables 3-6 through 3-8), but other shapes are permitted by 3.7.1.8. Manhole reinforcing plates or each segment of the plates if they are not made in one piece shall be provided with a 6 mm (1<sup>1</sup>/<sub>4</sub> in.) diameter tell-tale hole (for detection of leakage through the interior welds). Each hole shall be located on the horizontal centerline and shall be open to the atmosphere.

- **3.7.5.2** Manholes shall be of built-up welded construction. The dimensions are listed in Tables 3-3 through 3-5. The dimensions are based on the minimum neck thicknesses listed in Table 3-4. When corrosion allowance is specified to be applied to shell manholes, corrosion allowance is to be added to the minimum neck, cover plate, and bolting flange thicknesses of Tables 3-3 and 3-4.

**3.7.5.3** The maximum diameter  $D_p$  of a shell cutout shall be as listed in Column 3 of Table 3-7. Dimensions for required reinforcing plates are listed in Table 3-6.

**3.7.5.4** The gasket materials shall meet service requirements based on the product stored, temperature, and fire resistance. Gasket dimensions, when used in conjunction with thin-plate flanges described in Figure 3-4A, have proven effective when used with soft gaskets, such as non-asbestos fiber with suitable binder. When using hard gaskets, such as solid metal, corrugated metal, metal jacketed, and spiral-wound metal, the gasket dimensions, manhole flange, and manhole cover shall be designed per API Standard 620, Sections 3.20 and 3.21.

**3.7.5.5** In lieu of using Figure 3-4A or design per API Standard 620, forged flanges and forged blind flanges may be furnished per 2.6.

Minimum spacing shall be 8 times the shell thickness or  $\frac{1}{2}$  the radius of the opening, whichever is less

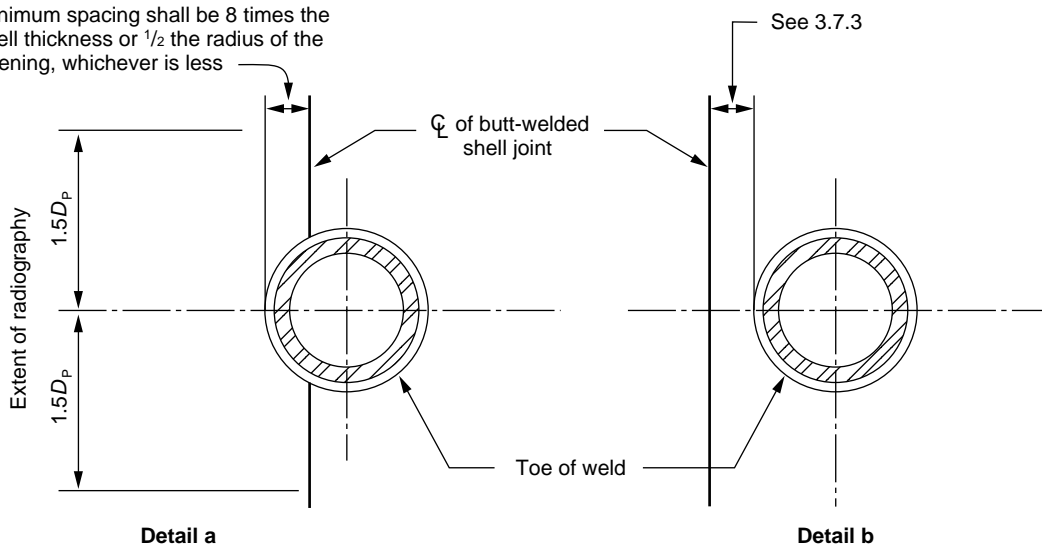

**PENETRATION WITHOUT REINFORCING PLATE**

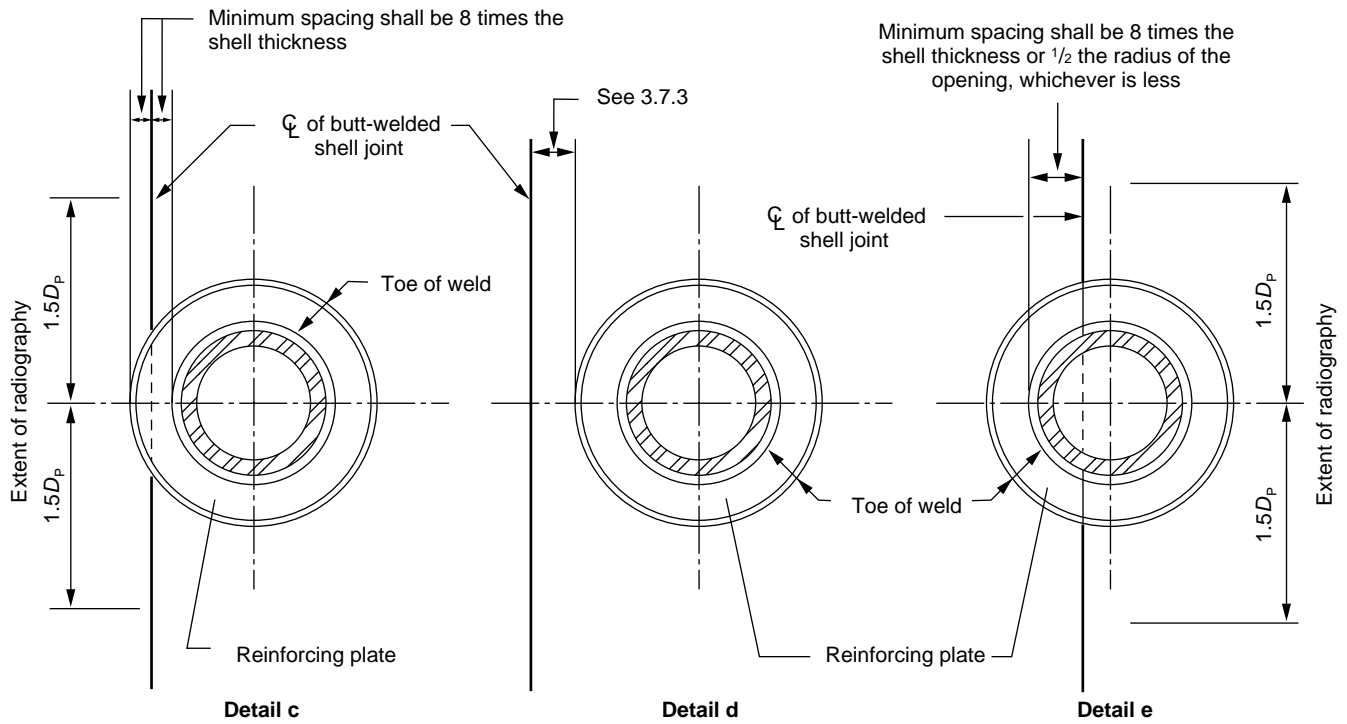

**PENETRATION WITH REINFORCING PLATE**

Note:  $D_p$  = diameter of opening.

Figure 3-6—Minimum Spacing of Welds and Extent of Related Radiographic Examination

Table 3-10—Minimum Thickness of Cover Plate, Bolting Flange, and Bottom Reinforcing Plate for Flush-Type Cleanout Fittings [mm (in.)]

Column 1	Column 2	Column 3	Column 4	Column 5	Column 6	Column 7	Column 8	Column 9	Column 10
		Size of Opening $h \times b$ (Height $\times$ Width)							
		200 $\times$ 400 (8 $\times$ 16)		600 $\times$ 600 (24 $\times$ 24)		900 $\times$ 1200 (36 $\times$ 48)		1200 $\times$ 1200 (48 $\times$ 48)	
Maximum Design Liquid Level m (ft) $H$	Equivalent Pressure <sup>a</sup> kPa (psi)	Thickness of Bolting Flange and Cover Plate $t_c$	Thickness of Bottom Reinforcing Plate <sup>b</sup> $t_b$	Thickness of Bolting Flange and Cover Plate $t_c$	Thickness of Bottom Reinforcing Plate <sup>c</sup> $t_b$	Thickness of Bolting Flange and Cover Plate $t_c$	Thickness of Bottom Reinforcing Plate <sup>d</sup> $t_b$	Thickness of Bolting Flange and Cover Plate $t_c$	Thickness of Bottom Reinforcing Plate <sup>e</sup> $t_b$
6.1 (20)	60 (8.7)	10 ( <sup>3</sup> / <sub>8</sub> )	13 ( <sup>1</sup> / <sub>2</sub> )	10 ( <sup>3</sup> / <sub>8</sub> )	13 ( <sup>1</sup> / <sub>2</sub> )	16 ( <sup>5</sup> / <sub>8</sub> )	21 ( <sup>13</sup> / <sub>16</sub> )	16 ( <sup>5</sup> / <sub>8</sub> )	22 ( <sup>7</sup> / <sub>8</sub> )
10 (34)	98 (14.7)	10 ( <sup>3</sup> / <sub>8</sub> )	13 ( <sup>1</sup> / <sub>2</sub> )	13 ( <sup>1</sup> / <sub>2</sub> )	13 ( <sup>1</sup> / <sub>2</sub> )	19 ( <sup>3</sup> / <sub>4</sub> )	25 (1)	21 ( <sup>13</sup> / <sub>16</sub> )	28 (1 <sup>1</sup> / <sub>8</sub> )
12 (41)	118 (17.8)	10 ( <sup>3</sup> / <sub>8</sub> )	13 ( <sup>1</sup> / <sub>2</sub> )	13 ( <sup>1</sup> / <sub>2</sub> )	14 ( <sup>9</sup> / <sub>16</sub> )	22 ( <sup>7</sup> / <sub>8</sub> )	28 (1 <sup>1</sup> / <sub>8</sub> )	22 ( <sup>7</sup> / <sub>8</sub> )	30 (1 <sup>3</sup> / <sub>16</sub> )
16 (53)	157 (23)	10 ( <sup>3</sup> / <sub>8</sub> )	13 ( <sup>1</sup> / <sub>2</sub> )	14 ( <sup>9</sup> / <sub>16</sub> )	16 ( <sup>5</sup> / <sub>8</sub> )	24 ( <sup>15</sup> / <sub>16</sub> )	32 (1 <sup>1</sup> / <sub>4</sub> )	25 (1)	33 (1 <sup>5</sup> / <sub>16</sub> )
18 (60)	177 (26)	11 ( <sup>7</sup> / <sub>16</sub> )	13 ( <sup>1</sup> / <sub>2</sub> )	16 ( <sup>5</sup> / <sub>8</sub> )	18 (1 <sup>1</sup> / <sub>16</sub> )	25 (1)	33 (1 <sup>5</sup> / <sub>16</sub> )	28 (1 <sup>1</sup> / <sub>8</sub> )	35 (1 <sup>3</sup> / <sub>8</sub> )
20 (64)	196 (27.8)	11 ( <sup>7</sup> / <sub>16</sub> )	13 ( <sup>1</sup> / <sub>2</sub> )	16 ( <sup>5</sup> / <sub>8</sub> )	18 (1 <sup>1</sup> / <sub>16</sub> )	27 (1 <sup>1</sup> / <sub>16</sub> )	35 (1 <sup>3</sup> / <sub>8</sub> )	28 (1 <sup>1</sup> / <sub>8</sub> )	36 (1 <sup>7</sup> / <sub>16</sub> )
22 (72)	216 (31.2)	11 ( <sup>7</sup> / <sub>16</sub> )	13 ( <sup>1</sup> / <sub>2</sub> )	18 (1 <sup>1</sup> / <sub>16</sub> )	19 ( <sup>3</sup> / <sub>4</sub> )	28 (1 <sup>1</sup> / <sub>8</sub> )	36 (1 <sup>7</sup> / <sub>16</sub> )	30 (1 <sup>3</sup> / <sub>16</sub> )	38 (1 <sup>1</sup> / <sub>2</sub> )

<sup>a</sup>Equivalent pressure is based on water loading.

<sup>b</sup>Maximum of 25 mm (1 in.).

<sup>c</sup>Maximum of 28 mm (1<sup>1</sup>/<sub>8</sub> in.).

<sup>d</sup>Maximum of 38 mm (1<sup>1</sup>/<sub>2</sub> in.).

<sup>e</sup>Maximum of 45 mm (1<sup>3</sup>/<sub>4</sub> in.).

Note: See Figure 3-9.

### 3.7.6 Shell Nozzles and Flanges

**3.7.6.1** Shell nozzles and flanges shall conform to Figures 3-4B, 3-5, and 3-7 and Tables 3-6 through 3-8, but other shapes are permitted by 3.7.1.8. Nozzle reinforcing plates or each segment of the plates if they are not made in one piece shall be provided with a 6 mm (1/4 in.) diameter tell-tale hole. Such holes shall be located substantially on the horizontal centerline and shall be open to the atmosphere.

**3.7.6.2** The details and dimensions specified in this standard are for nozzles installed with their axes perpendicular to the shell plate. A nozzle may be installed at an angle other than 90 degrees to the shell plate in a horizontal plane, provided the width of the reinforcing plate ( $W$  or  $D_o$  in Figure 3-5 and Table 3-6) is increased by the amount that the horizontal chord of the opening cut in the shell plate ( $D_p$  in Figure 3-5 and Table 3-7) increases as the opening is changed from circular to elliptical for the angular installation. In addition, nozzles not larger than NPS 3—for the insertion of thermometer wells, for sampling connections, or for other purposes not involving the attachment of extended piping—may be installed at an angle of 15 degrees or less off perpendicular in a vertical plane without modification of the nozzle reinforcing plate.

**3.7.6.3** The minimum thickness of nozzle neck to be used shall be equal to the required thickness as identified by the term  $t_n$  in Table 3-6, Column 3.

### 3.7.7 Flush-Type Cleanout Fittings

**3.7.7.1** Flush-type cleanout fittings shall conform to the requirements of 3.7.7.2 through 3.7.7.12 and to the details and dimensions shown in Figures 3-9 and 3-10 and Tables 3-9 through 3-11. When a size intermediate to the sizes given in Tables 3-9 through 3-11 is specified by the purchaser, the construction details and reinforcements shall conform to the next larger opening listed in the tables. The size of the opening or tank connection shall not be larger than the maximum size given in the appropriate table.

**3.7.7.2** The opening shall be rectangular, but the upper corners of the opening shall have a radius equal to one-half the greatest height of the clear opening. When the shell material is Group I, II, III, or IIIA, the width or height of the clear opening shall not exceed 1200 mm (48 in.); when the shell material is Group IV, IVA, V, or VI, the height shall not exceed 900 mm (36 in.).

**3.7.7.3** The reinforced opening shall be completely preassembled into a shell plate, and the completed unit, including the shell plate at the cleanout fitting, shall be thermally stress-relieved as described in 3.7.4 (regardless of the thickness or strength of the material).

**3.7.7.4** The cross-sectional area of the reinforcement over the top of the opening shall be calculated as follows:

00 |

01 |

00

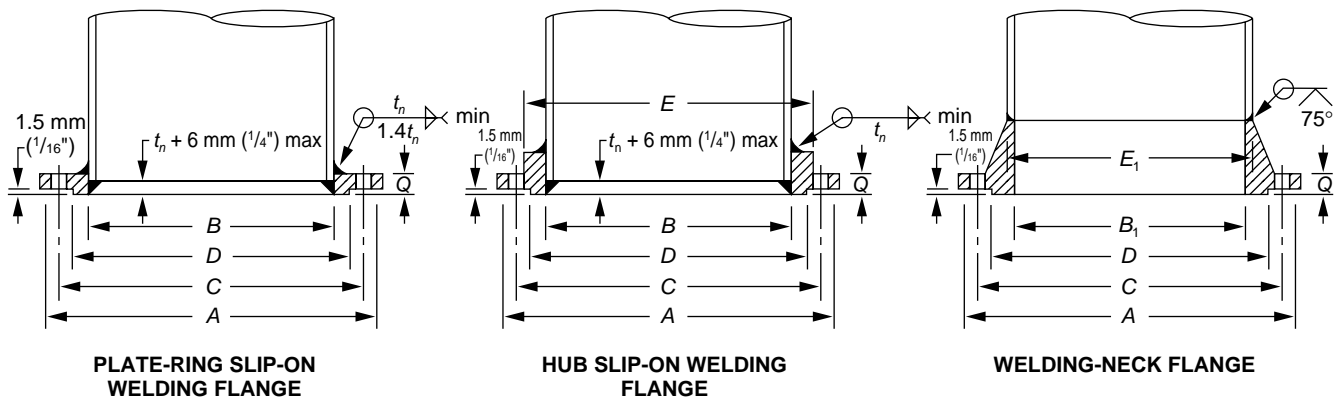

Note: The  $t_n$  designated for weld thickness is the nominal pipe wall thickness (see Tables 3-6 and 3-7).

Figure 3-7—Shell Nozzle Flanges (See Table 3-8)

Vertical axis in SI units:

$$\left[ \frac{(H + 8.8) D + 71.5}{1.408 h} \right] \left[ \frac{123 t}{4.9 D (H - 0.3)} \right]^{0.5}$$

Vertical axis in US Customary units:

$$\left[ \frac{(H + 29) D + 770}{385 h} \right] \left[ \frac{17,850 t}{2.6 D (H - 1)} \right]^{0.5}$$

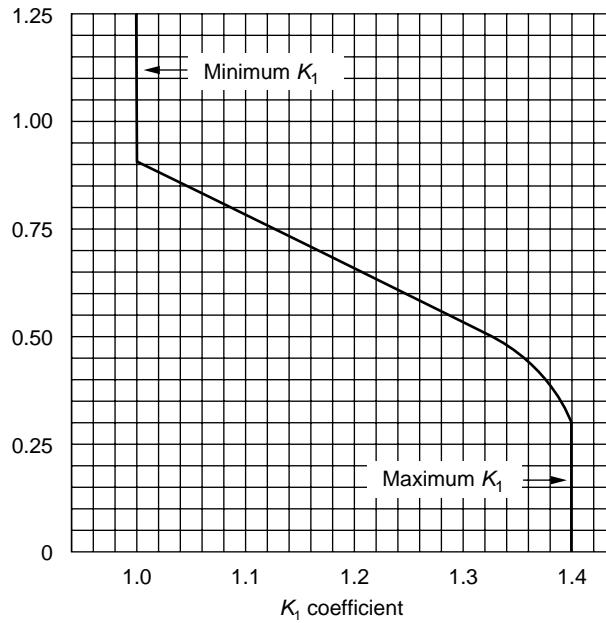

Figure 3-8—Area Coefficient for Determining Minimum Reinforcement of Flush-Type Cleanout Fittings

$$A_{cs} \geq \frac{K_1 h t}{2}$$

where

$A_{cs}$  = cross-sectional area of the reinforcement over the top of the opening, in  $\text{mm}^2$  ( $\text{in.}^2$ ),

$K_1$  = area coefficient from Figure 3-8,

$h$  = vertical height of clear opening, in mm (in.),

$t$  = calculated thickness of the lowest shell course, in mm (in.), required by the formulas of 3.6.3, 3.6.4, or A.4.1 but exclusive of any corrosion allowance.

**3.7.7.5** The thickness of the shell plate in the cleanout-opening assembly shall be at least as thick as the adjacent shell plate in the lowest shell course. The thickness of the shell reinforcing plate and the neck plate shall be the same as the thickness of the shell plate in the cleanout-opening assembly.

The reinforcement in the plane of the shell shall be provided within a height  $L$  above the bottom of the opening.  $L$  shall not exceed  $1.5h$  except that, in the case of small openings,  $L - h$  shall not be less than 150 mm (6 in.). Where this exception results in an  $L$  that is greater than  $1.5h$ , only the portion of the reinforcement that is within the height of  $1.5h$  shall be considered effective. The reinforcement required may be provided by any one or any combination of the following:

00  
01

- a. The shell reinforcing plate.
- b. Any thickness of the shell plate in the cleanout-door assembly that is greater than the thickness of the adjacent plates in the lowest shell course.
- c. The portion of the neck plate having a length equal to the thickness of the reinforcing plate.

**3.7.7.6** The minimum width of the tank-bottom reinforcing plate at the centerline of the opening shall be 250 mm (10 in.) plus the combined thickness of the shell plate in the cleanout-opening assembly and the shell reinforcing plate.

The minimum thickness of the bottom reinforcing plate shall be determined by the following equation:

In SI units:

$$98 \quad t_b = \frac{h^2}{360,000} + \frac{b}{170} \sqrt{HG}$$

where

- $t_b$  = minimum thickness of the bottom reinforcing plate, in mm,
  - $h$  = vertical height of clear opening, in mm,
  - $b$  = horizontal width of clear opening, in mm,
  - $H$  = maximum design liquid level (see 3.6.3.2), in m.
- 98 |  $G$  = specific gravity, not less than 1.0.

In US Customary units:

$$98 \quad t_b = \frac{h^2}{14,000} + \frac{b}{310} \sqrt{HG}$$

where

- $t_b$  = minimum thickness of the bottom reinforcing plate, (in.),
  - $h$  = vertical height of clear opening, (in.),
  - $b$  = horizontal width of clear opening, (in.),
  - $H$  = maximum design liquid level (see 3.6.3.2), (ft),
- 98 |  $G$  = specific gravity, not less than 1.0.

**3.7.7.7** The dimensions of the cover plate, bolting flange, bolting, and bottom-reinforcing plate shall conform to Tables 3-9 and 3-10.

01 | **3.7.7.8** All materials in the flush-type cleanout fitting assembly shall conform to the requirements in Section 2. The shell plate containing the cleanout assembly, the shell reinforcing plate, the neck plate, and the bottom reinforcing plate shall meet the impact test requirements of 2.2.9 and Figure 2-1 for the respective thickness involved at the stated design metal temperature for the tank. The notch toughness of the bolting flange and the cover plate shall be based on the governing

thickness as defined in 2.5.5.3 using Table 2-3(a), Table 2-3(b), and Figure 2-1. Additionally, the yield strength and the tensile strength of the shell plate at the flush-type cleanout fitting, the shell reinforcing plate, and the neck plate shall be equal to, or greater than, the yield strength and the tensile strength of the adjacent lowest shell course plate material.

**3.7.7.9** The dimensions and details of the cleanout-opening assemblies covered by this section are based on internal hydrostatic loading with no external-piping loading.

**3.7.7.10** When a flush-type cleanout fitting is installed on a tank that is resting on an earth grade without concrete or masonry walls under the tank shell, provision shall be made to support the fitting and retain the grade by either of the following methods:

- a. Install a vertical steel bulkhead plate under the tank, along the contour of the tank shell, symmetrical with the opening, as shown in Figure 3-10, Method A.
- b. Install a concrete or masonry retaining wall under the tank with the wall's outer face conforming to the contour of the tank shell as shown in Figure 3-10, Method B.

**3.7.7.11** When a flush-type cleanout fitting is installed on a tank that is resting on a ringwall, a notch with the dimensions shown in Figure 3-10, Method C, shall be provided to accommodate the cleanout fitting.

**3.7.7.12** When a flush-type cleanout fitting is installed on a tank that is resting on an earth grade inside a foundation retaining wall, a notch shall be provided in the retaining wall to accommodate the fitting, and a supplementary inside retaining wall shall be provided to support the fitting and retain the grade. The dimensions shall be as shown in Figure 3-10, Method D.

### 3.7.8 Flush-Type Shell Connections

- **3.7.8.1** Tanks may have flush-type connections at the lower edge of the shell. Each connection may be made flush with the flat bottom under the following conditions (see Figure 3-11):
  - a. The shell uplift from the internal design and test pressures (see Appendix F) and wind and earthquake loads (see Appendix E) shall be counteracted so that no uplift will occur at the cylindrical-shell/flat-bottom junction.
  - b. The vertical or meridional membrane stress in the cylindrical shell at the top of the opening for the flush-type connection shall not exceed one-tenth of the circumferential design stress in the lowest shell course containing the opening.
  - c. The maximum width,  $b$ , of the flush-type connection opening in the cylindrical shell shall not exceed 900 mm (36 in.).
  - d. The maximum height,  $h$ , of the opening in the cylindrical shell shall not exceed 300 mm (12 in.).
  - e. The thickness,  $t_a$ , of the bottom transition plate in the assembly shall be 12.5 mm ( $1/2$  in.) minimum or, when specified, the same as the thickness of the tank annular plate.

Table 3-11—Thicknesses and Heights of Shell Reinforcing Plates for Flush-Type Cleanout Fittings [mm (in.)]

	Thickness of Lowest Shell Course $t, t_d^a$ mm (ft)	Maximum Design Liquid Level <sup>c</sup> $H$ m (ft)	Height of Shell Reinforcing Plate for Size of Opening $h \times b$ (Height $\times$ Width) mm (ft)			
			200 $\times$ 400 (8 $\times$ 16)	600 $\times$ 600 (24 $\times$ 24)	900 $\times$ 1200 (36 $\times$ 48)	1200 $\times$ 1200 (48 $\times$ 48)
00	All	< 22 (72)	350 (14)	915 (36)	1372 (54)	1830 (72)

Notes:

<sup>a</sup>Dimensions  $t_d$  and  $L$  may be varied within the limits defined in 3.7.7.<sup>b</sup>1200 x 1200 (48 x 48) flush-type cleanout fittings are not permitted for tanks with greater than 38 mm (1½ in.) lowest shell course thickness.<sup>c</sup>See 3.6.3.2.

01

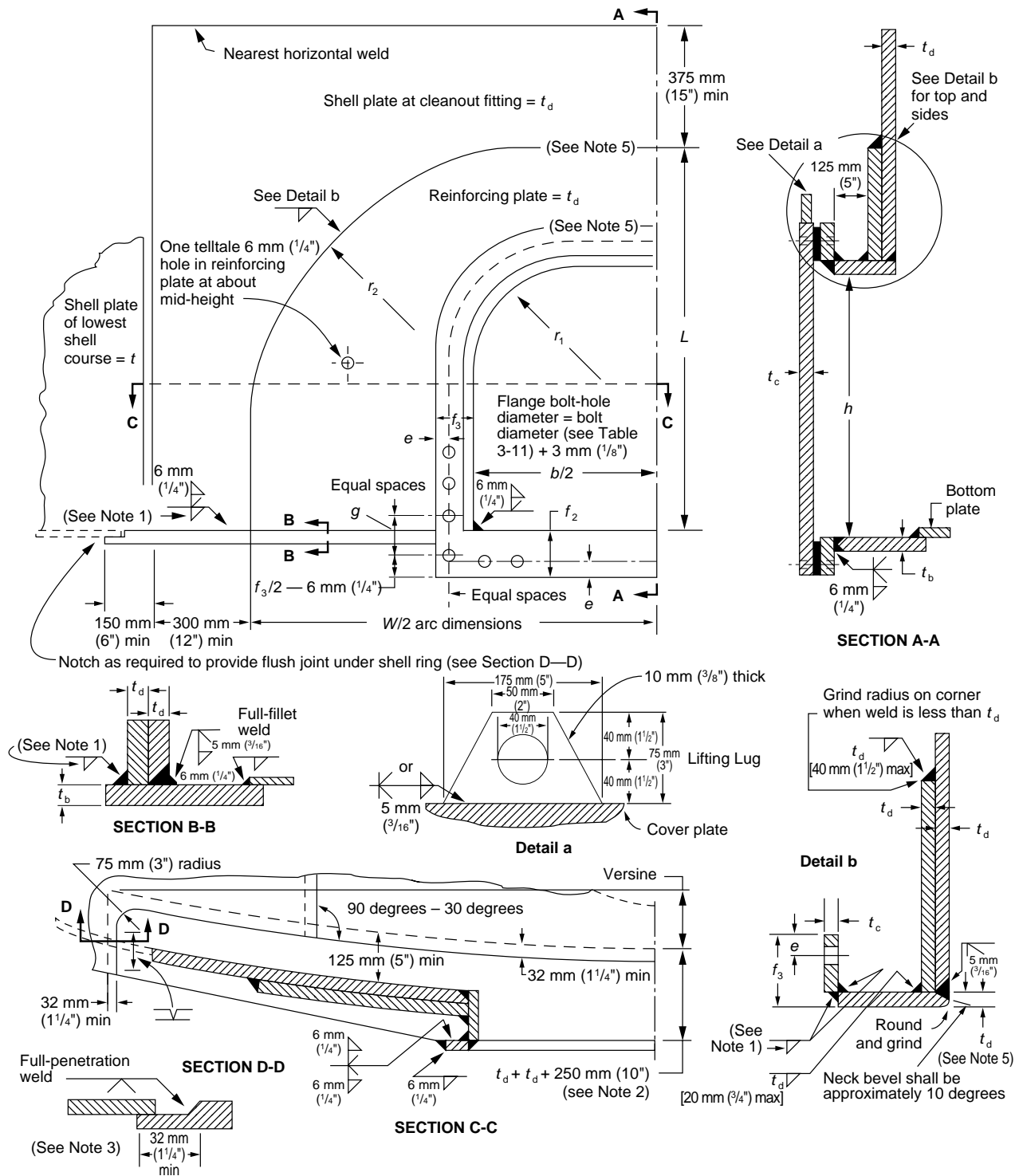

- Notes:
1. Thickness of thinner plate joined [13 mm ( $1/2$  in.) maximum].
  2. When an annular plate is provided, the reinforcing plate shall be regarded as a segment of the annular plate and shall be the same width as the annular plate.
  3. When the difference between the thickness of the annular ring and that of the bottom reinforcing plate is less than 6 mm ( $1/4$  in.), the radial joint between the annular ring and the bottom reinforcing plate may be butt-welded with a weld joint suitable for complete penetration and fusion.
  4. Gasket material shall be specified by the purchaser. The gasket material shall meet service requirements based on product stored, temperature and fire resistance.
  5. The thickness ( $t_d$ ) of the shell plate at the cleanout opening, the reinforcing plate, and the neck plate, shall be equal to or greater than the thickness ( $t$ ) of the shell plate of the lowest shell course.

Figure 3-9—Flush-Type Cleanout Fittings (See Tables 3-9, 3-10, and 3-11)

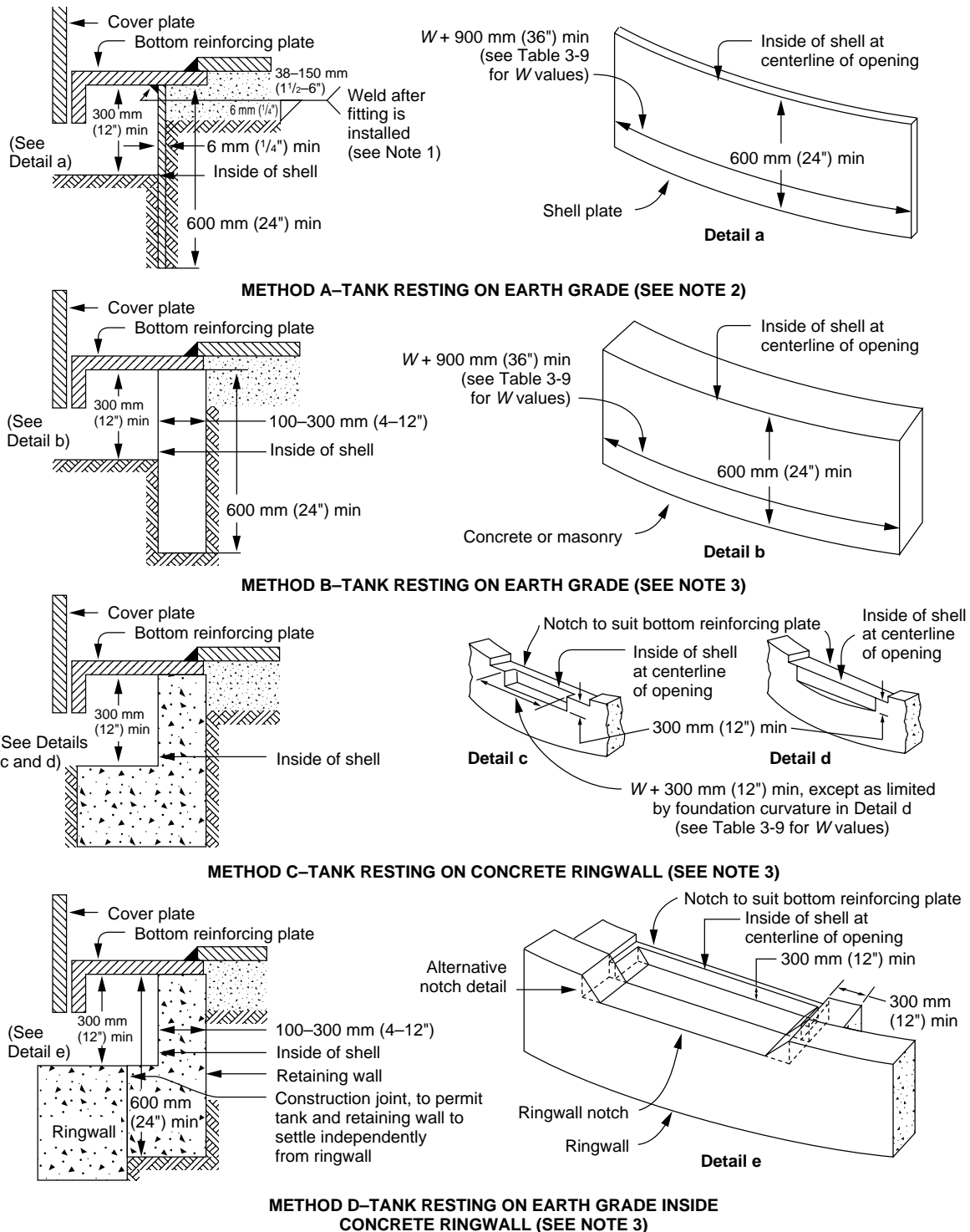

Notes:

1. This weld is not required if the earth is stabilized with portland cement at a ratio of not more than 1:12 or if the earth fill is replaced with concrete for a lateral distance and depth of at least 300 mm (12 in.).
2. When Method A is used, before the bottom plate is attached to the bottom reinforcing plate, (a) a sand cushion shall be placed flush with the top of the bottom reinforcing plate, and (b) the earth fill and sand cushion shall be thoroughly compacted.

3. When Method B, C, or D is used, before the bottom plate is attached to the bottom reinforcing plate, (a) a sand cushion shall be placed flush with the top of the bottom reinforcing plate, (b) the earth fill and sand cushion shall be thoroughly compacted, and (c) grout shall be placed under the reinforcing plate (if needed) to ensure a firm bearing.

Figure 3-10—Flush-Type Cleanout-Fitting Supports (See 3.7.7)

Table 3-12—Dimensions for Flush-Type Shell Connections [mm (in.)]

Class 150 Nominal Height of Flange Size	Height of Opening $h$	Width of Opening $b$	Arc Width of Shell Reinforcing Plate $W$	Upper Corner Radius of Opening $r_1$	Lower Corner Radius of Shell Reinforcing Plate $r_2$
8	200 (8 <sup>5/8</sup> )	200 (8 <sup>5/8</sup> )	950 (38)	100 <sup>a</sup>	350 (14)
12	300 (12 <sup>3/4</sup> )	300 (12 <sup>3/4</sup> )	1300 (52)	150 <sup>a</sup>	450 (18)
16	300 (12)	500 (20)	1600 (64)	150 (6)	450 (18)
18	300 (12)	550 (22)	1650 (66)	150 (6)	450 (18)
20	300 (12)	625 (25)	1725 (69)	150 (6)	450 (18)
24	300 (12)	900 (36)	2225 (89)	150 (6)	450 (18)

<sup>a</sup>For circular openings, this value will be  $1/2$  of the ID based on the nozzle neck specified.  
Note: See Figure 3-11.

**3.7.8.2** The details of the connection shall conform to those shown in Figure 3-11, and the dimensions of the connection shall conform to Table 3-12 and to the requirements of 3.7.8.3 through 3.7.8.11.

**3.7.8.3** The reinforced connection shall be completely pre-assembled into a shell plate. The completed assembly, including the shell plate containing the connection, shall be thermally stress-relieved at a temperature of 600°C to 650°C (1100°F to 1200°F) for 1 hour per 25 mm (1 in.) of shell-plate thickness,  $t_d$  (see 3.7.4.1 and 3.7.4.2).

**3.7.8.4** The reinforcement for a flush-type shell connection shall meet the following requirements:

- The cross-sectional area of the reinforcement over the top of the connection shall not be less than  $K_1ht/2$  (see 3.7.7.4).
- The thickness of the shell plate,  $t_d$ , for the flush-connection assembly shall be at least as thick as the adjacent shell plate,  $t$ , in the lowest shell course.
- The thickness of the shell reinforcing plate shall be the same as the thickness of the shell plate in the flush-connection assembly.
- The reinforcement in the plane of the shell shall be provided within a height  $L$  above the bottom of the opening.  $L$  shall not exceed  $1.5h$  except that, in the case of small openings,  $L - h$  shall not be less than 150 mm (6 in.). Where this exception results in an  $L$  that is greater than  $1.5h$ , only the portion of the reinforcement that is within the height of  $1.5h$  shall be considered effective.
- The required reinforcement may be provided by any one or any combination of the following: (1) the shell reinforcing plate, (2) any thickness of the shell plate in the assembly that is greater than the thickness of the adjacent plates in the lowest shell course, and (3) the portion of the neck plate having a length equal to the thickness of the reinforcing plate.
- The width of the tank-bottom reinforcing plate at the centerline of the opening shall be 250 mm (10 in.) plus the combined thickness of the shell plate in the flush-connection assembly and the shell reinforcing plate. The thickness of the bottom reinforcing plate shall be calculated by the following equation (see 3.7.7.6):

In SI units:

$$t_b = \frac{h^2}{360,000} + \frac{b}{170} \sqrt{HG}$$

where

- $t_b$  = minimum thickness of the bottom reinforcing plate, in mm,
- $h$  = vertical height of clear opening, in mm,
- $b$  = horizontal width of clear opening, in mm,
- $H$  = maximum design liquid level (see 3.6.3.2), in m,
- $G$  = specific gravity, not less than 1.0.

In US Customary units:

$$t_b = \frac{h^2}{14,000} + \frac{b}{310} \sqrt{HG}$$

where

- $t_b$  = minimum thickness of the bottom reinforcing plate, (in.),
- $h$  = vertical height of clear opening, (in.),
- $b$  = horizontal width of clear opening, (in.),
- $H$  = maximum design liquid level (see 3.6.3.2), (ft),
- $G$  = specific gravity, not less than 1.0.

The minimum value of  $t_b$  shall be:

- 16 mm (5/8 in.) for  $HG \leq 14.4$  m (48 ft),
- 17 mm (11/16 in.) for  $14.4$  m (48 ft)  $< HG \leq 16.8$  m (56 ft),
- 19 mm (3/4 in.) for  $16.8$  m (56 ft)  $< HG \leq 19.2$  m (64 ft).

g. The minimum thickness of the nozzle neck and transition piece,  $t_n$ , shall be 16 mm (5/8 in.). External loads applied to the connection may require  $t_n$  to be greater than 16 mm (5/8 in.).

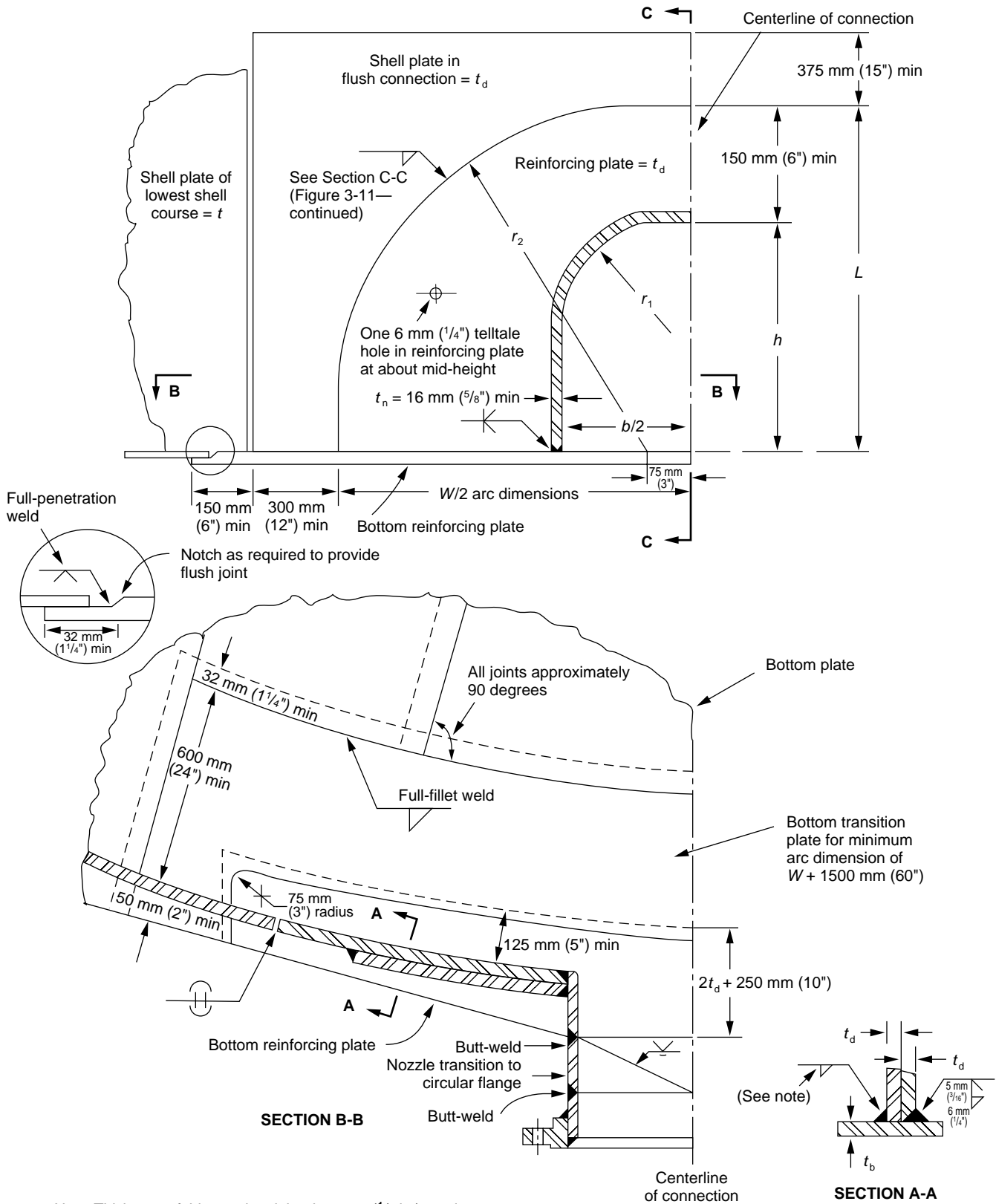

Figure 3-11—Flush-Type Shell Connection



**3.7.8.5** All materials in the flush-type shell connection assembly shall conform to the requirements in Section 2. The material of the shell plate in the connection assembly, the shell reinforcing plate, the nozzle neck attached to the shell, the transition piece, and the bottom reinforcing plate shall conform to 2.2.9 and Figure 2-1 for the respective thickness involved at the stated design metal temperature for the tank. The notch toughness of the bolting flange and the nozzle neck attached to the bolting flange shall be based on the governing thickness as defined in 2.5.5.3 and used in Figure 2-1. Additionally, the yield strength and the tensile strength of the shell plate at the flush-type shell connection and the shell reinforcing plate shall be equal to, or greater than, the yield strength

and the tensile strength of the adjacent lowest shell course plate material.

**3.7.8.6** The nozzle transition between the flush connection in the shell and the circular pipe flange shall be designed in a manner consistent with the requirements of this standard. Where this standard does not cover all details of design and construction, the manufacturer shall provide details of design and construction that will be as safe as the details provided by this standard.

**3.7.8.7** Where anchoring devices are required by Appendixes E and F to resist shell uplift, the devices shall be spaced so that they will be located immediately adjacent to each side of the reinforcing plates around the opening.

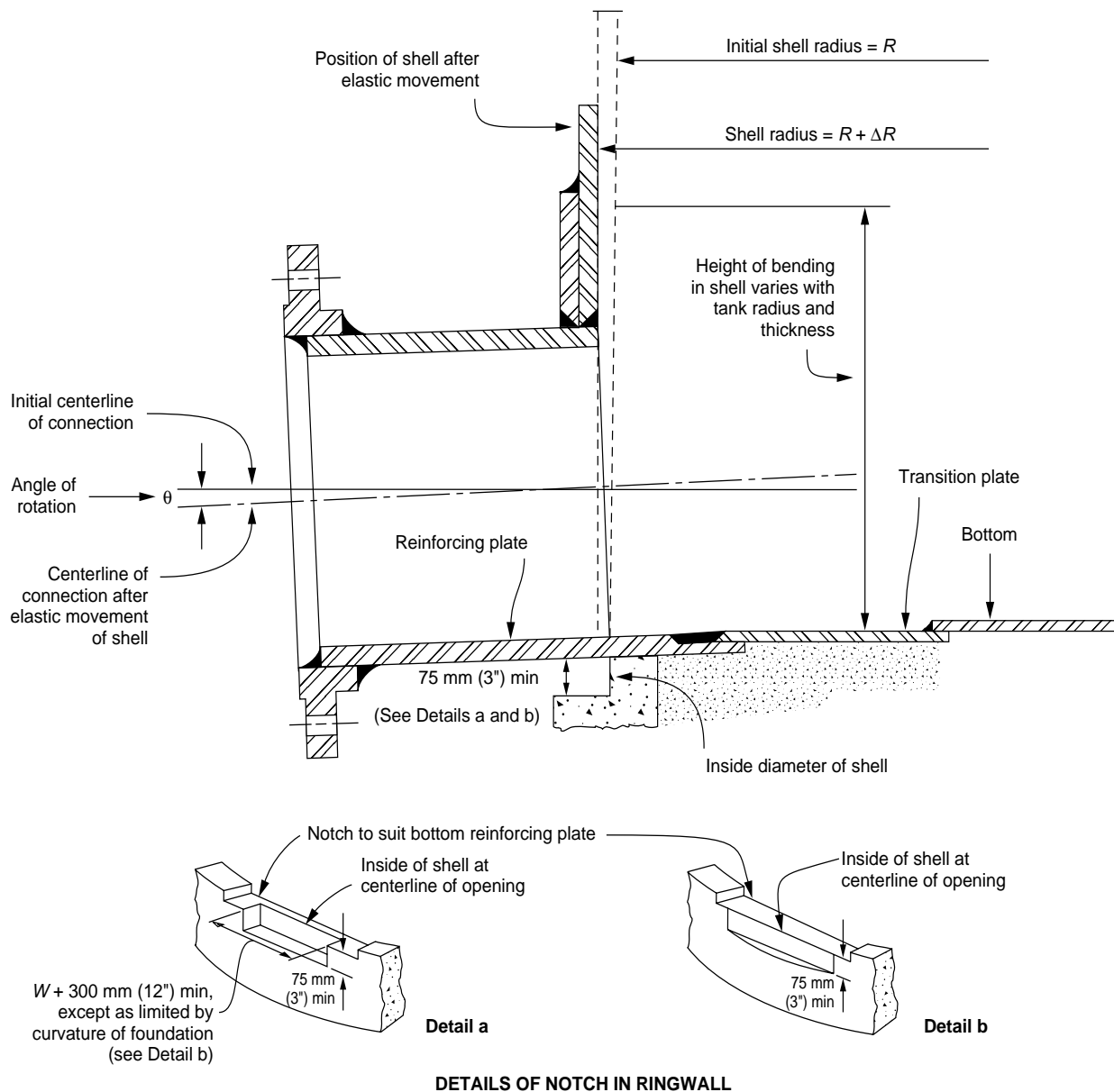

Figure 3-12—Rotation of Shell Connection

**3.7.8.8** Adequate provision shall be made for free movement of connected piping to minimize thrusts and moments applied to the shell connection. Allowance shall be made for the rotation of the shell connection caused by the restraint of the tank bottom to shell expansion from stress and temperature as well as for the thermal and elastic movement of the piping. Rotation of the shell connection is shown in Figure 3-12.

**3.7.8.9** The foundation in the area of a flush-type connection shall be prepared to support the bottom reinforcing plate of the connection. The foundation for a tank resting on a concrete ringwall shall provide uniform support for both the bottom reinforcing plate and the remaining bottom plate under the tank shell. Different methods of supporting the bottom reinforcing plate under a flush-type connection are shown in Figure 3-10.

**3.7.8.10** Flush-type connections may be installed using a common reinforcing pad; however, when this construction is employed, the minimum distance between nozzle centerlines shall not be less than  $1.5[b_1 + b_2 + 65 \text{ mm } (2\frac{1}{2} \text{ in.})]$ , where  $b_1$  and  $b_2$  are the widths of adjacent openings, or 600 mm (24 in.), whichever is greater. The width of each opening,  $b$ , shall be obtained from Table 3-12 for the respective nominal flange size. Adjacent shell flush-type connections that do not share a common reinforcing plate shall have at least a 900 mm (36 in.) clearance between the ends of their reinforcing plates.

**3.7.8.11** All longitudinal butt-welds in the nozzle neck and transition piece, if any, and the first circumferential butt-weld in the neck closest to the shell, excluding neck-to-flange weld, shall receive 100% radiographic examination (see 6.1). The nozzle-to-tank-shell and reinforcing plate welds and the shell-to-bottom reinforcing plate welds shall be examined for their complete length by magnetic particle examination (see 6.2). The magnetic particle examination shall be performed on the root pass, on every 12.5 mm ( $\frac{1}{2}$  in.) of deposited weld metal while the welds are made, and on the completed welds. The completed welds shall also be visually examined. The examination of the completed welds shall be performed after stress-relieving but before hydrostatic testing (see 6.2 and 6.5 for the appropriate inspection and repair criteria).

### 3.8 SHELL ATTACHMENTS AND TANK APPURTENANCES

#### 3.8.1 Shell Attachments

**3.8.1.1** Shell attachments shall be made, inspected, and removed in conformance with Section 5. Shell attachments are surface attachments such as fit-up equipment, angles, clips, and stair treads.

**3.8.1.2** When attachments are made to shell courses of material in Group IV, IVA, V, or VI, the movement of the shell (particularly the movement of the bottom course) under hydrostatic loading shall be considered, and the attachments shall meet the following requirements:

- a. Permanent attachments may be welded directly to the shell with fillet welds having a maximum leg dimension of 13 mm ( $\frac{1}{2}$  in.). The edge of any permanent attachment welds shall be at least 75 mm (3 in.) from the horizontal joints of the shell and at least 150 mm (6 in.) from the vertical joints, insert-plate joints, or reinforcing-plate fillet welds. Permanent attachment welds may cross shell horizontal or vertical butt welds providing the welds are continuous within these limits and the angle of incidence between the two welds is greater than or equal to 45 degrees. Additionally, any splice weld in the permanent attachment shall be located a minimum of 150 mm (6 in.) from any shell weld unless the splice weld is kept from intersecting the shell weld by acceptable modifications to the attachment.
- b. The welding and inspection of permanent attachments to these shell courses shall conform to 5.2.3.5.
- c. Temporary attachments to shell courses shall preferably be made prior to welding of the shell joints. Weld spacing for temporary attachments made after welding of the shell joints shall be the same as that required for permanent attachments. Temporary attachments to shell courses shall be removed, and any resulting damage shall be repaired and ground to a smooth profile.

#### ● 3.8.2 Bottom Connections

Connections to the tank bottom are permitted subject to agreement between the purchaser and the manufacturer with respect to details that provide strength, tightness, and utility equal to the details of shell connections specified in this standard.

#### 3.8.3 Cover Plates

**3.8.3.1** Unreinforced openings less than or equal to NPS 2 pipe size are permissible in flat cover plates without increasing the cover plate thickness if the edges of the openings are not closer to the center of the cover plate than one-fourth the height or diameter of the opening. Requirements for openings NPS 2 pipe size and smaller that do not satisfy the location requirement and for larger reinforced openings are given in 3.8.3.2 through 3.8.3.4.

**3.8.3.2** Reinforced openings in the cover plates of shell manholes shall be limited to one-half the diameter of the manhole opening but shall not exceed NPS 12 pipe size. The reinforcement added to an opening may be a reinforcing plate or an increased thickness of the cover plate, but in either case, the reinforcement shall provide an added reinforcing area no less than the cutout area of the opening in the cover plate.

A cover plate with a nozzle attachment for product-mixing equipment shall have a thickness at least 1.4 times greater than the thickness required by Table 3-3. The added thickness (or pad plate) for replacement of the opening cutout in the cover plate shall be based on Table 3-3. The 40% increase in thickness within a radius of one diameter of the opening may be included as part of the area of replacement required. The mixer-nozzle attachment to the cover plate shall be a full-penetration weld. The manhole bolting-flange thickness shall not be less than 1.4 times the thickness required by Table 3-3.

**3.8.3.3** When cover plates (or blind flanges) are required for shell nozzles, the minimum thickness shall be that given for flanges in Table 3-8. Reinforced openings in the cover plates (or blind flanges) of shell nozzles shall be limited to one-half the diameter of the nozzle. The reinforcement added to an opening may be an added pad plate or an increased thickness of the cover plate, but in either case, the reinforcement shall provide an added reinforcing area no less than 50% of the cutout area of the opening in the cover plate. Mixer nozzles may be attached to cover plates.

**3.8.3.4** Openings in the cover plates of flush-type cleanout fittings shall be limited to NPS 2 pipe size in accordance with 3.8.3.1.

### 3.8.4 Roof Manholes

Roof manholes shall conform to Figure 3-13 and Table 3-13. If work is expected to be carried on through the manhole opening while the tank is in use, the roof structure around the manhole shall be reinforced.

### 3.8.5 Roof Nozzles

**3.8.5.1** Flanged roof nozzles shall conform to Figure 3-16 and Table 3-14. Slip-on welding and welding-neck flanges shall conform to the requirements of ASME B16.5 for Class 150 forged carbon steel raised-face flanges. Plate-ring flanges shall conform to all of the dimensional requirements for slip-on welding flanges with the exception that the extended hub on the back of the slip-on welding flanges can be omitted.

**3.8.5.2** Threaded roof nozzles shall conform to Figure 3-17 and Table 3-15.

### 3.8.6 Rectangular Roof Openings

**3.8.6.1** Rectangular roof openings in supported roofs shall conform to Figure 3-14 or 3-15 and/or this section. If work is expected to be carried on through the roof opening, while the tank is in use, the roof structure around the roof opening shall be reinforced.

**3.8.6.2** The cover plate thickness and/or structural support shall be designed to limit maximum fiber stresses in accordance with this standard, however, cover plate thickness shall not be less than 5 mm ( $3/16$  in.). In addition to other expected design loads, consider a 112 kg (250 lb) person standing in the center of the installed/closed cover. The designer shall consider wind in the design of hinged openings and how removed covers will be handled without damage (adequate rigidity).

**3.8.6.3** Rectangular openings, other than shown in Figures 3-14 and 3-15, and openings larger than indicated shall be designed by an engineer experienced in tank design in accordance with this standard. Hinged covers prescribed in Figure

3-15 may not be used on roofs designed to contain internal pressure. Flanged covers prescribed in Figure 3-14 may not be used on tanks with internal pressures (acting across the cross sectional area of the tank roof) that exceed the weight of the roof plates. This section applies only to fixed steel roofs.

### ● 3.8.7 Water Drawoff Sumps

Water drawoff sumps shall be as specified in Figure 3-18 and Table 3-16, unless otherwise specified by the purchaser.

### 3.8.8 Scaffold-Cable Support

The scaffold-cable support shall conform to Figure 3-19. Where seams or other attachments are located at the center of the tank roof, the scaffold support shall be located as close as possible to the center.

### 3.8.9 Threaded Connections

Threaded piping connections shall be female and tapered. The threads shall conform to the requirements of ASME B1.20.1 for tapered pipe threads.

### 3.8.10 Platforms, Walkways, and Stairways

Platforms, walkways, and stairways shall be in accordance with Tables 3-17, 3-18, and 3-19.

## 3.9 TOP AND INTERMEDIATE WIND GIRDERS

### 3.9.1 General

An open-top tank shall be provided with stiffening rings to maintain roundness when the tank is subjected to wind loads. The stiffening rings shall be located at or near the top of the top course, preferably on the outside of the tank shell. This design for wind girders applies to floating-roof tanks covered in Appendix C. The top angle and the wind girders shall conform, in material and size, to the requirements of this standard.

### 3.9.2 Types of Stiffening Rings

Stiffening rings may be made of structural sections, formed plate sections, sections built up by welding, or combinations of such types of sections assembled by welding. The outer periphery of stiffening rings may be circular or polygonal (see Figure 3-20).

### 3.9.3 Restrictions on Stiffening Rings

**3.9.3.1** The minimum size of angle for use alone or as a component in a built-up stiffening ring shall be  $64 \times 64 \times 6.4$  mm ( $2\frac{1}{2} \times 2\frac{1}{2} \times \frac{1}{4}$  in.). The minimum nominal thickness of plate for use in formed or built-up stiffening rings shall be 6 mm ( $\frac{1}{4}$  in.).

00 |

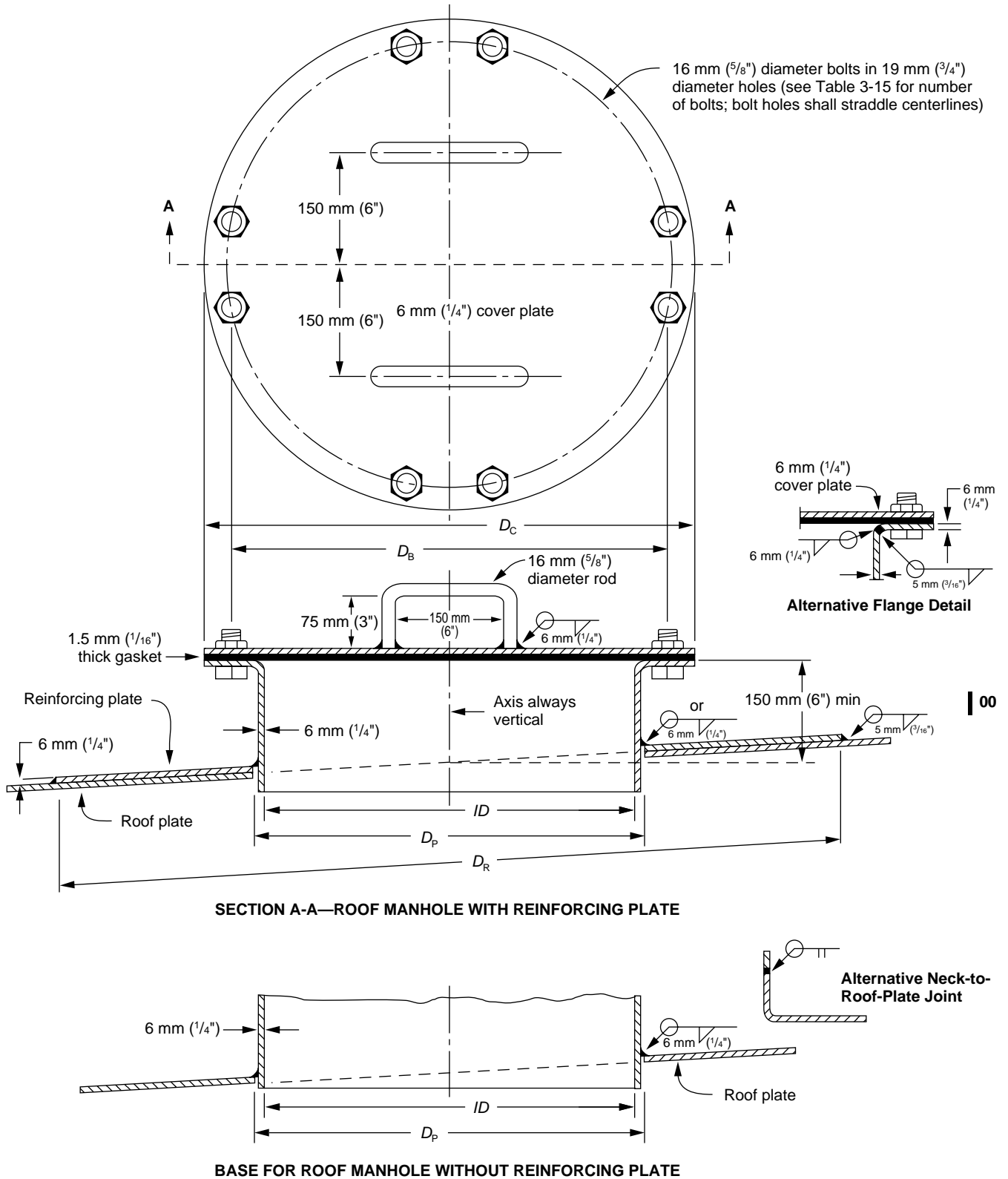

Figure 3-13—Roof Manholes (See Table 3-13)

Table 3-13—Dimensions for Roof Manholes [mm (in.)]

Column 1	Column 2	Column 3	Column 4	Column 5	Column 6	Column 7	Column 8	Column 9
Size of Manhole	Diameter of Neck $ID^a$	Diameter of Cover Plate $D_C$	Diameter of Bolt Circle $D_B$	Number of Bolts	Diameter of Gasket		Diameter of Hole in Roof Plate or Reinforcing Plate $D_P$	Outside Diameter of Reinforcing Plate $D_R$
					Inside	Outside		
500 (20)	500 (20)	650 (26)	590 (23 $\frac{1}{2}$ )	16	500 (20)	650 (26)	515 (20 $\frac{5}{8}$ )	1050 (42)
600 (24)	600 (24)	750 (30)	690 (27 $\frac{1}{2}$ )	20	600 (24)	750 (30)	615 (24 $\frac{5}{8}$ )	1150 (46)

<sup>a</sup>Pipe may be used for neck, providing the minimum nominal wall thickness is 6 mm ( $\frac{1}{4}$  in.). ( $ID$  and  $D_p$  shall be adjusted accordingly.)

Note: See Figure 3-15.

Table 3-14—Dimensions for Flanged Roof Nozzles [mm (in.)]

Column 1	Column 2	Column 3	Column 4	Column 5
Nozzle NPS	Outside Diameter of Pipe Neck	Diameter of Hole in Roof Plate or Reinforcing Plate $D_P$	Minimum Height of Nozzle $H_R$	Outside Diameter of Reinforcing Plate <sup>a</sup> $D_R$
2	60.3 (23/8)	65 (2 $\frac{1}{2}$ )	150 (6)	175 (7)
3	88.9 (3 $\frac{1}{2}$ )	92 (3 $\frac{5}{8}$ )	150 (6)	225 (9)
4	114.3 (4 $\frac{1}{2}$ )	120 (4 $\frac{5}{8}$ )	150 (6)	275 (11)
6	168.3 (6 $\frac{5}{8}$ )	170 (6 $\frac{3}{4}$ )	150 (6)	375 (15)
8	219.1 (8 $\frac{5}{8}$ )	225 (8 $\frac{7}{8}$ )	150 (6)	450 (18)
10	273.0 (10 $\frac{3}{4}$ )	280 (11)	200 (8)	550 (22)
12	323.8 (12 $\frac{3}{4}$ )	330 (13)	200 (8)	600 (24)

<sup>a</sup>Reinforcing plates are not required on nozzles NPS 6 or smaller but may be used if desired.

Note: See Figure 3-16.

Table 3-15—Dimensions for Threaded Roof Nozzles [mm (in.)]

Column 1	Column 2	Column 3	Column 4
Nozzle NPS	Coupling NPS	Diameter of Hole in Roof Plate or Reinforcing Plate $D_P$	Outside Diameter of Reinforcing Plate <sup>a</sup> $D_R$
1	1	44 (1 $\frac{23}{32}$ )	110 (4 $\frac{1}{2}$ )
1 $\frac{1}{2}$	1 $\frac{1}{2}$	60 (2 $\frac{11}{32}$ )	125 (5)
2	2	76 (3)	175 (7)
3	3	105 (4 $\frac{1}{8}$ )	225 (9)
4	4	135 (5 $\frac{11}{32}$ )	275 (11)
6	6	192 (7 $\frac{17}{32}$ )	375 (15)
8	8	250 (9 $\frac{7}{8}$ )	450 (18)
10	10	305 (12)	550 (22)
12	12	360 (14 $\frac{1}{4}$ )	600 (24)

<sup>a</sup>Reinforcing plates are not required on nozzles NPS 6 or smaller but may be used if desired.

Note: See Figure 3-17.

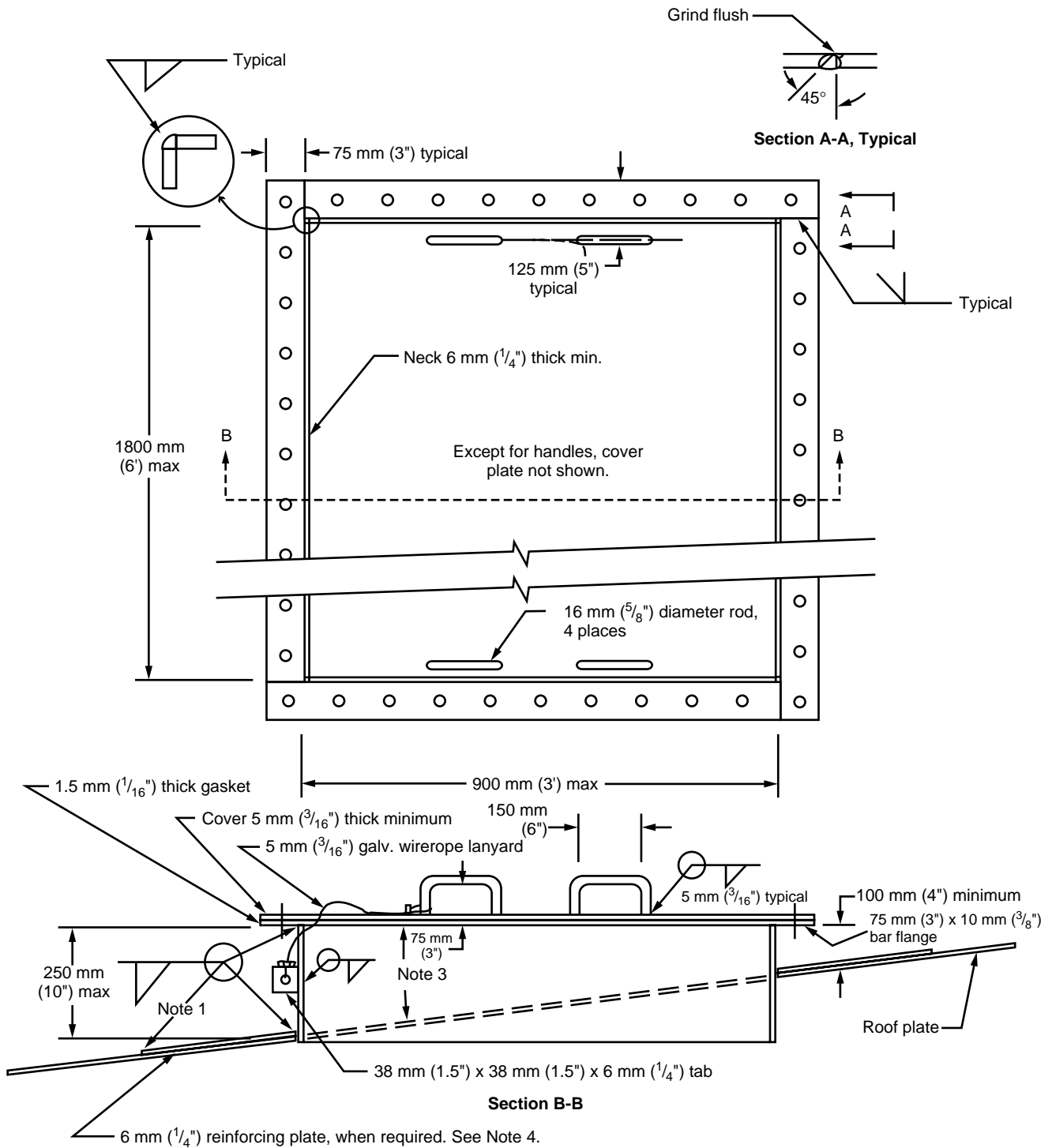
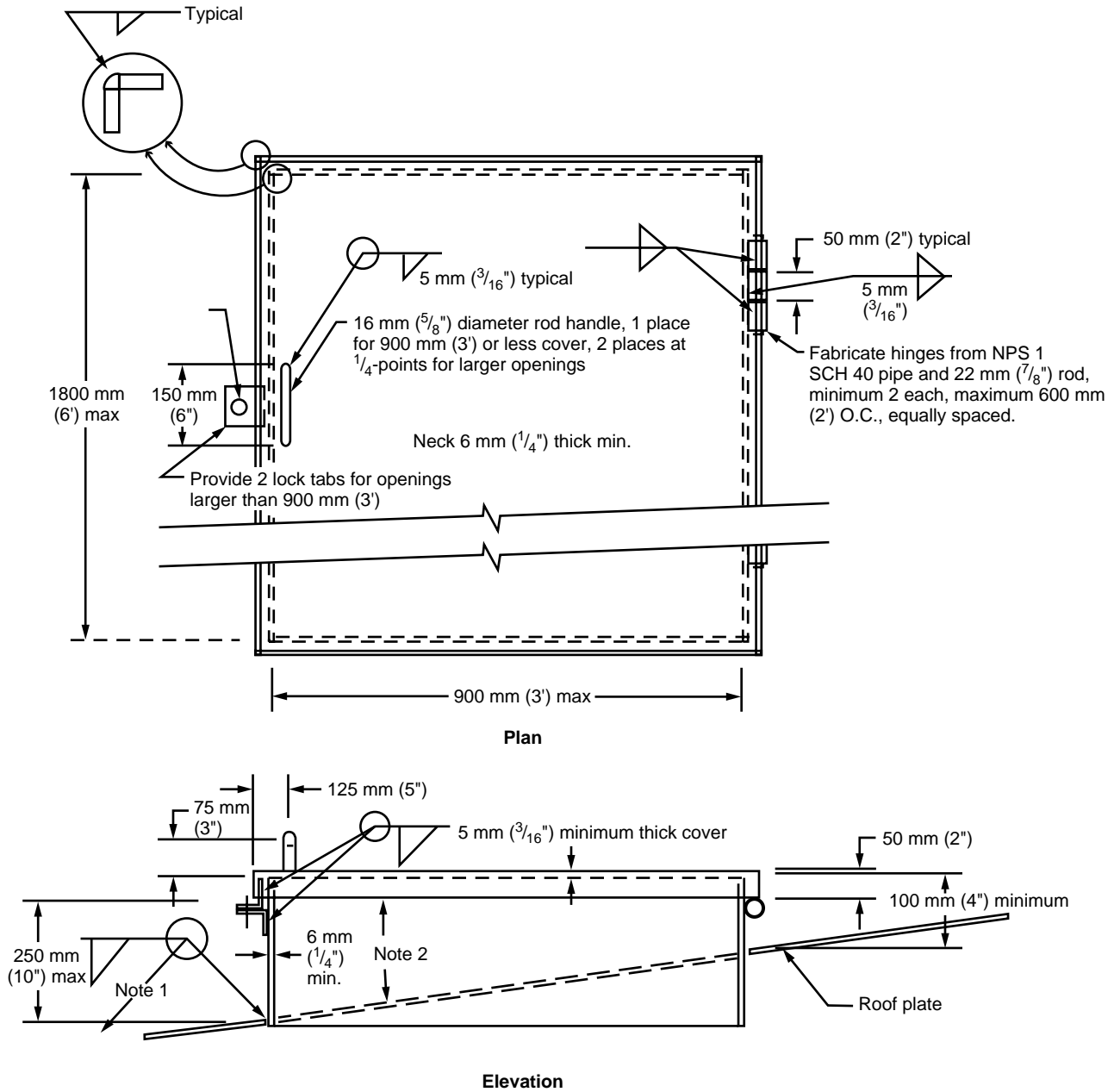

Figure 3-14—Rectangular Roof Openings with Flanged Covers



Notes:

1. Weld size shall be the smaller of the plate thicknesses being joined.
2. Cover may be either parallel to roof or horizontal. Opening may be oriented as desired.
3. Reinforcement, when required, shall be as shown in Figure 3-16.
4. Not for use on roofs designed to contain internal pressure.

Figure 3-15—Rectangular Roof Openings with Hinged Cover

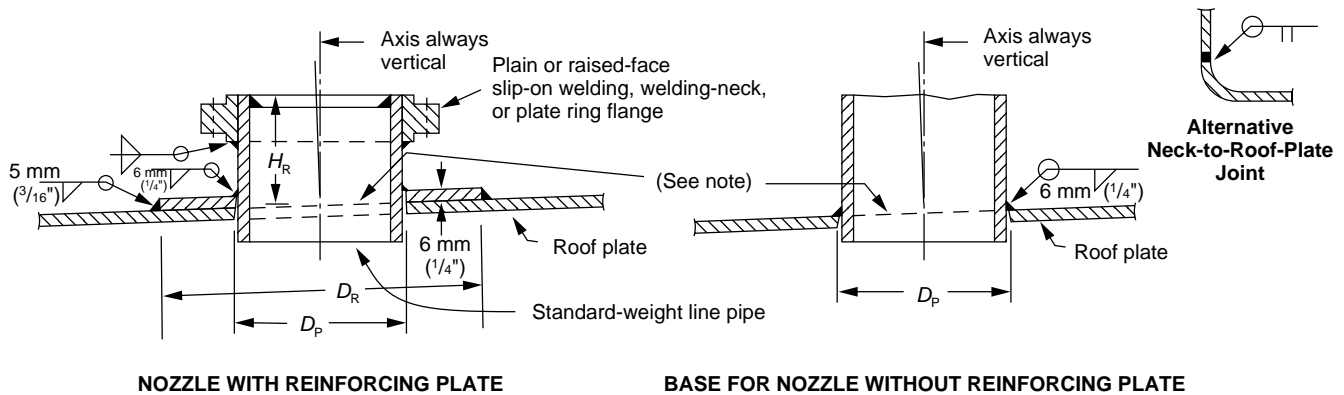

Note: When the roof nozzle is used for venting, the neck shall be trimmed flush with the roofline.

Figure 3-16—Flanged Roof Nozzles (See Table 3-14)

**3.9.3.2** When the stiffening rings are located more than 0.6 m (2 ft) below the top of the shell, the tank shall be provided with a  $64 \times 64 \times 4.8$  mm ( $2\frac{1}{2} \times 2\frac{1}{2} \times \frac{3}{16}$  in.) top curb angle for shells 5 mm ( $\frac{3}{16}$  in.) thick, with a  $76 \times 76 \times 6.4$  mm ( $3 \times 3 \times \frac{1}{4}$  in.) angle for shells more than 5 mm ( $\frac{3}{16}$  in.) thick, or with other members of equivalent section modulus.

**3.9.3.3** Rings that may trap liquid shall be provided with adequate drain holes.

**3.9.3.4** Welds joining stiffening rings to the tank shell may cross vertical tank seam welds. Any splice weld in the ring shall be located a minimum of 150 mm (6 in.) from any vertical shell weld. Stiffening rings may also cross vertical tank seam welds with the use of coping (rat hole) of the stiffening ring at the vertical tank seam. Where the coping method is used, the required section modulus of the stiffening ring and weld spacing must be maintained.

### 3.9.4 Stiffening Rings As Walkways

A stiffening ring or any portion of it that is specified as a walkway shall have a width not less than 600 mm (24 in.) clear of the projecting curb angle on the top of the tank shell. It shall preferably be located 1100 mm (42 in.) below the top of the curb angle and shall be provided with a standard railing on the unprotected side and at the ends of the section used as a walkway.

### 3.9.5 Supports For Stiffening Rings

Supports shall be provided for all stiffening rings when the dimension of the horizontal leg or web exceeds 16 times the leg or web thickness. The supports shall be spaced at the intervals required for the dead load and vertical live load; however, the spacing shall not exceed 24 times the width of the outside compression flange.

### 3.9.6 Top Wind Girder

**3.9.6.1** The required minimum section modulus of the stiffening ring shall be determined by the following equation:

In SI units:

$$Z = \frac{D^2 H_2}{17}$$

where

- $Z$  = required minimum section modulus ( $\text{cm}^3$ ),
- $D$  = nominal tank diameter (m),
- $H_2$  = height of the tank shell (m), including any free-board provided above the maximum filling height as a guide for a floating roof.

In US Customary units:

$$Z = 0.0001 D^2 H_2$$

where

- $Z$  = required minimum section modulus ( $\text{in.}^3$ ),
- $D$  = nominal tank diameter (ft),
- $H_2$  = height of the tank shell (ft), including any free-board provided above the maximum filling height as a guide for a floating roof.

- Note: This equation is based on a wind velocity of 160 km/h (100 mph). If specified by the purchaser, other wind velocities may be used by multiplying the right side of the equation by  $(V/160 \text{ km/h})^2$ , where  $V$  equals the wind velocity in km/h [ $(V/100 \text{ mph})^2$  where  $V$  equals the wind velocity in mph]. If the design wind velocity has not been specified and if the maximum allowable wind velocity calculated for the tank shell is less than 160 km/h (100 mph), the calculated velocity may be used provided it is reported to the purchaser. For tank diameters over 60 m (200 ft), the section modulus required by the equation may be reduced by agreement between the purchaser and the manufacturer, but the modulus may not be less than that required for a tank diameter of 60 m (200 ft). (A description of the loads on the tank shell that are included in the 160 km/h (100 mph) design wind velocity can be found in item a of the note to 3.9.7.1.)

Table 3-16—Dimensions for Drawoff Sumps

NPS	Diameter of Sump	Depth of Sump	Distance from	Thickness of Plates	Minimum Internal Pipe Thickness	Minimum Nozzle Neck Thickness
	mm (in.) <i>A</i>	mm (in.) <i>B</i>	Center Pipe to Shell m (ft) <i>C</i>	in Sump mm (in.) <i>t</i>		
2	610 (24)	300 (12)	1.1 (3 <sup>1</sup> / <sub>2</sub> )	8 ( <sup>5</sup> / <sub>16</sub> )	5.54 (0.218)	5.54 (0.218)
3	910 (36)	450 (18)	1.5 (5)	10 ( <sup>3</sup> / <sub>8</sub> )	6.35 (0.250)	7.62 (0.300)
4	1220 (48)	600 (24)	2.1 (6 <sup>3</sup> / <sub>4</sub> )	10 ( <sup>3</sup> / <sub>8</sub> )	6.35 (0.250)	8.56 (0.337)
6	1520 (60)	900 (36)	2.6 (8 <sup>1</sup> / <sub>2</sub> )	11 ( <sup>7</sup> / <sub>16</sub> )	6.35 (0.250)	10.97 (0.432)

Note: See Figure 3-16.

**3.9.6.2** The section modulus of the stiffening ring shall be based on the properties of the applied members and may include a portion of the tank shell for a distance of 16 plate thicknesses below and, if applicable, above the shell-ring attachment. When curb angles are attached to the top edge of the shell ring by butt-welding, this distance shall be reduced by the width of the vertical leg of the angle (see Figure 3-20 and Table 3-20).

**3.9.6.3** When a stair opening is installed through a stiffening ring, the section modulus of the portion of the ring outside the opening, including the transition section, shall conform to the requirements of 3.9.6.1. The shell adjacent to the opening shall be stiffened with an angle or a bar, the wide side of which is placed in a horizontal plane. The other sides of the opening shall also be stiffened with an angle or a bar, the wide side of which is placed in a vertical plane. The cross-sectional area of these rim stiffeners shall be greater than or equal to the cross-sectional area of the portion of shell included in the section-modulus calculations for the stiffening ring. These rim stiffeners or additional members shall provide a suitable toeboard around the opening.

The stiffening members shall extend beyond the end of the opening for a distance greater than or equal to the minimum depth of the regular ring sections. The end stiffening members shall frame into the side stiffening members, and the end and side stiffening members shall be connected to ensure that their full strength is developed. Figure 3-21 shows the opening described above. Alternative details that provide a load-carrying capacity equal to that of the girder cross section away from the opening may be provided.

### 3.9.7 Intermediate Wind Girders

**3.9.7.1** The maximum height of the unstiffened shell shall be calculated as follows:

In SI units:

$$H_1 = 9.47t \sqrt{\left(\frac{t}{D}\right)^3}$$

where

$H_1$  = vertical distance, in m, between the intermediate wind girder and the top angle of the shell or the top wind girder of an open-top tank,

$t$  = as ordered thickness, unless otherwise specified, of the top shell course (mm),

$D$  = nominal tank diameter (m).

In US Customary units:

$$H_1 = 600,000t \sqrt{\left(\frac{t}{D}\right)^3}$$

where

$H_1$  = vertical distance, in ft, between the intermediate wind girder and the top angle of the shell or the top wind girder of an open-top tank,

$t$  = as ordered thickness, unless otherwise specified, of the top shell course (in.),

$D$  = nominal tank diameter (ft).

Note: This formula is intended to cover tanks with either open tops or closed tops and is based on the following factors (for the background for the factors given in this note, see R. V. McGrath's "Stability of API Standard 650 Tank Shells"):<sup>13</sup>

- a. A design wind velocity ( $V$ ) of 160 km/h (100 mph), which imposes a dynamic pressure of 1.23 kPa (25.6 lbf/ft<sup>2</sup>). The velocity is increased by 10% for either a height above ground or a gust factor; thus the pressure is increased to 1.48 kPa (31 lbf/ft<sup>2</sup>). An additional 0.24 kPa (5 lbf/ft<sup>2</sup>) is added to account for inward drag associated with open-top tanks or for internal vacuum associated with closed-top tanks. A total of 1.72 kPa (36 lbf/ft<sup>2</sup>) is obtained. For the purposes of this standard, this pressure is intended to be the result of a 160 km/h (100 mph) fastest mile velocity at approximately 9 m (30 ft) above ground.  $H_1$  may be modified for other wind velocities, as specified by the purchaser, by multiplying the

<sup>13</sup>R. V. McGrath, "Stability of API Standard 650 Tank Shells," *Proceedings of the American Petroleum Institute, Section III—Refining*, American Petroleum Institute, New York, 1963, Vol. 43, pp. 458–469.

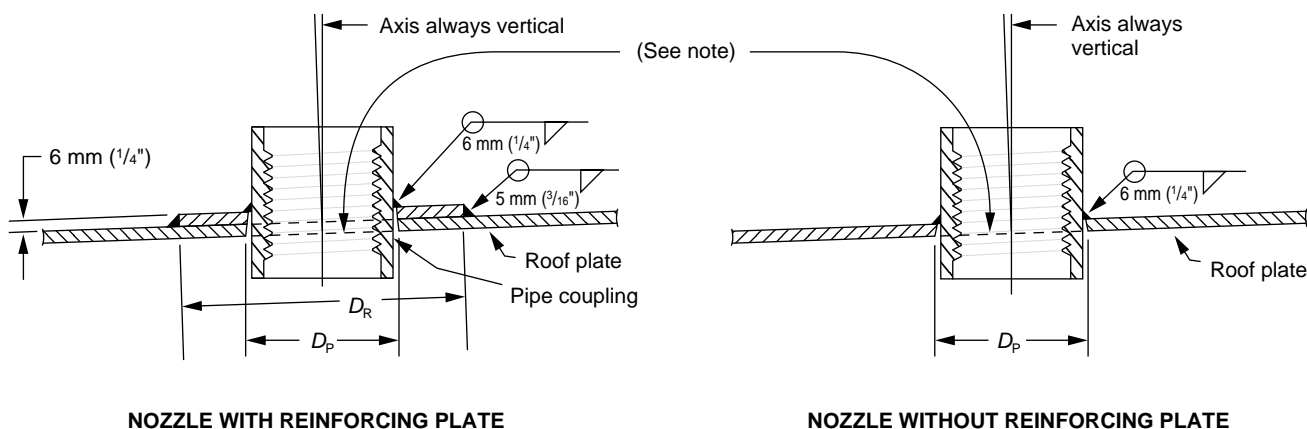

Note: See

3.8.8 for requirements for threaded connections. When the roof nozzle is used for venting,

Figure 3-17—Threaded Roof Nozzles (See Table 3-15)

Table 3-17—Requirements for Platforms and Walkways

1. All parts shall be made of metal.
2. The minimum width of the floor level shall be 610 mm (24 in.).
3. Flooring shall be made of grating or nonslip material.
4. The height of the top railing above the floor shall be 1070 mm (42 in.).<sup>a</sup>
5. The minimum height of the toeboard shall be 75 mm (3 in.).
6. The maximum space between the top of the floor and the bottom of the toeboard shall be 6 mm (1/4 in.).
7. The height of the midrail shall be approximately one-half the distance from the top of the walkway to the top of the railing.
8. The maximum distance between railing posts shall be 2400 mm (96 in.).
9. The completed structure shall be capable of supporting a moving concentrated load of 4450 N (1000 lbf), and the handrail structure shall be capable of withstanding a load of 890 N (200 lbf) applied in any direction at any point on the top rail.
10. Handrails shall be on both sides of the platform but shall be discontinued where necessary for access.
11. At handrail openings, any space wider than 150 mm (6 in.) between the tank and the platform should be floored.
12. A tank runway that extends from one part of a tank to any part of an adjacent tank, to the ground, or to another structure shall be supported so that free relative movement of the structures joined by the runway is permitted. This may be accomplished by firm attachment of the runway to one tank and the use of a slip joint at the point of contact between the runway and the other tank. (This method permits either tank to settle or be disrupted by an explosion without the other tank being endangered.)

<sup>a</sup>This handrail height is required by ANSI specifications. It is mandatory in some states.

Table 3-18—Requirements for Stairways

1. All parts shall be made of metal.
2. The minimum width of the stairs shall be 610 mm (24 in.).
3. The maximum angle<sup>a</sup> of the stairway with a horizontal line shall be 50 degrees.
4. The minimum width of the stair treads shall be 200 mm (8 in.). [The sum of twice the rise of the stair treads plus the run (defined as the horizontal distance between the noses of successive tread pieces) shall not be less than 610 mm (24 in.) or more than 660 mm (26 in.). Rises shall be uniform throughout the height of the stairway.]
5. Treads shall be made of grating or nonslip material.
6. The top railing shall join the platform handrail without offset, and the height measured vertically from tread level at the nose of the tread shall be 760 to 860 mm (30 to 34 in.).
7. The maximum distance between railing posts, measured along the slope of the railing, shall be 2400 mm (96 in.).
8. The completed structure shall be capable of supporting a moving concentrated load of 4450 N (1000 lbf), and the handrail structure shall be capable of withstanding a load of 890 N (200 lbf) applied in any direction at any point on the top rail.
9. Handrails shall be on both sides of straight stairs; handrails shall also be on both sides of circular stairs when the clearance between the tank shell and the stair stringer exceeds 200 mm (8 in.).
10. Circumferential stairways should be completely supported on the shell of the tank, and the ends of the stringers should be clear of the ground.

<sup>a</sup>It is recommended that the same angle be employed for all stairways in a tank group or plant area.

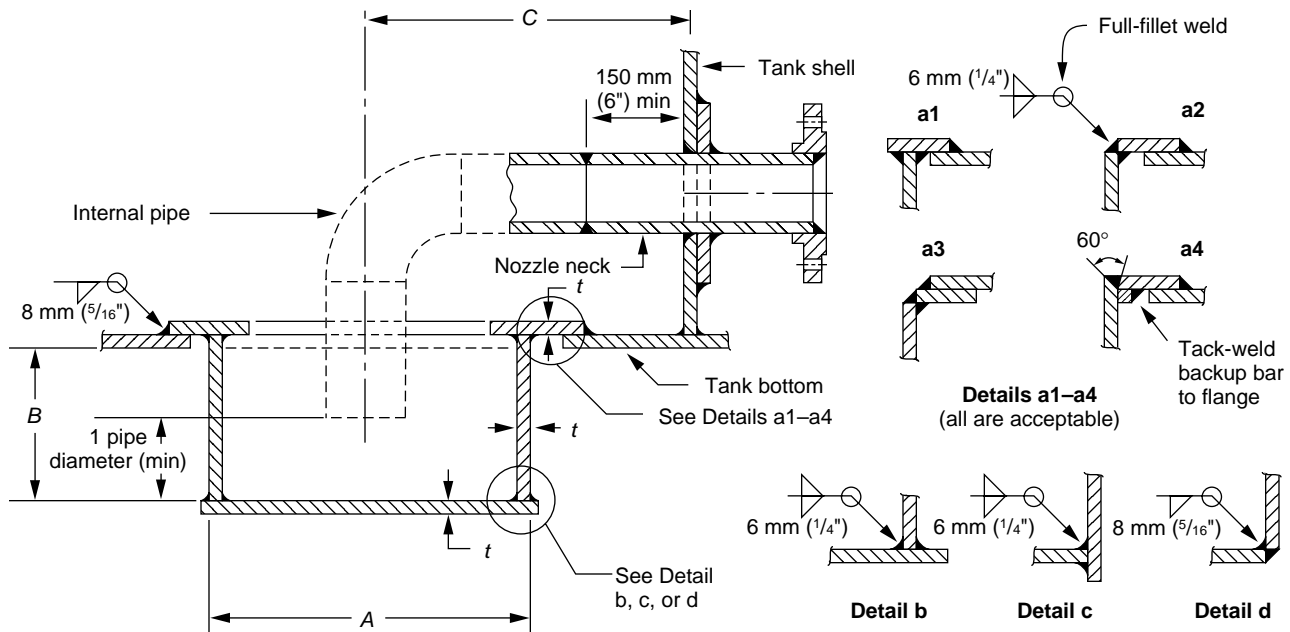

Note: The erection procedure shall include the following steps: (a) a hole shall be cut in the bottom plate or a sump shall be placed in the foundation before bottom placement; (b) a neat excavation shall be made to conform to the shape of the drawoff sump, the sump shall be put in place, and the foundation shall be compacted around the sump after placement; and (c) the sump shall be welded to the bottom.

Figure 3-18—Drawoff Sump (See Table 3-16)

right side of the equation by  $[(V_r / V)^2]$ , where  $V_r = 160$  km/h (100 mph). When a design wind pressure, rather than a wind velocity, is specified by the purchaser, the preceding increase factors should be added to the purchaser's specified wind pressure unless they are contained within the design wind pressure specified by the purchaser.

b. The wind pressure being uniform over the theoretical buckling mode of the tank shell, which eliminates the need for a shape factor for the wind loading.

c. The modified U.S. Model Basin formula for the critical uniform external pressure on thin-wall tubes free from end loadings, subject to the total pressure specified in item a.

- d. Other factors specified by the purchaser. When other factors are specified by the purchaser that are greater than the factors in items a–c, the total load on the shell shall be modified accordingly, and  $H_1$  shall be decreased by the ratio of 1.72 kPa (36 lbf/ft<sup>2</sup>) to the modified total pressure.

**3.9.7.2** After the maximum height of the unstiffened shell,  $H_1$ , has been determined, the height of the transformed shell shall be calculated as follows:

a. With the following equation, change the actual width of each shell course into a transposed width of each shell course having the top shell thickness:

$$W_{tr} = W \sqrt[5]{\left(\frac{t_{uniform}}{t_{actual}}\right)^5}$$

where

$W_{tr}$  = transposed width of each shell course, mm (in.),

$W$  = actual width of each shell course, mm (in.),

$t_{uniform}$  = as ordered thickness, unless otherwise specified, of the top shell course, mm (in.),

$t_{actual}$  = as ordered thickness, unless otherwise specified, of the shell course for which the transposed width is being calculated, mm (in.).

b. Add the transposed widths of the courses. The sum of the transposed widths of the courses will give the height of the transformed shell.

**3.9.7.3** If the height of the transformed shell is greater than the maximum height  $H_1$ , an intermediate wind girder is required.

**3.9.7.3.1** For equal stability above and below the intermediate wind girder, the girder should be located at the mid-height of the transformed shell. The location of the girder on the actual shell should be at the same course and same relative position as the location of the girder on the transformed shell, using the thickness relationship above.

**3.9.7.3.2** Other locations for the girder may be used, provided the height of unstiffened shell on the transformed shell does not exceed  $H_1$  (see 3.9.7.5).

100

Table 3-19—Rise, Run, and Angle Relationships for Stairways

Height of Rise mm (in.) <i>R</i>	$2R + r = 610 \text{ mm (24 in.)}$			$2R + r = 660 \text{ mm (26 in.)}$		
	Width of Run mm (in.) <i>r</i>	Angle		Width of Run mm (in.) <i>r</i>	Angle	
		Degrees	Minutes		Degrees	Minutes
135 (5 <sup>1</sup> / <sub>4</sub> )	340 (13 <sup>1</sup> / <sub>2</sub> )	21	39	—	—	—
140 (5 <sup>1</sup> / <sub>2</sub> )	330 (13)	22	59	380 (15)	20	13
145 (5 <sup>3</sup> / <sub>4</sub> )	320 (12 <sup>1</sup> / <sub>2</sub> )	24	23	370 (14 <sup>1</sup> / <sub>2</sub> )	21	24
150 (6)	310 (12)	25	49	360 (14)	22	37
155 (6 <sup>1</sup> / <sub>4</sub> )	300 (11 <sup>1</sup> / <sub>2</sub> )	27	19	350 (13 <sup>1</sup> / <sub>2</sub> )	23	53
165 (6 <sup>1</sup> / <sub>2</sub> )	280 (11)	30	31	330 (13)	26	34
170 (6 <sup>3</sup> / <sub>4</sub> )	270 (10 <sup>1</sup> / <sub>2</sub> )	32	12	320 (12 <sup>1</sup> / <sub>2</sub> )	27	59
180 (7)	250 (10)	35	45	300 (12)	30	58
185 (7 <sup>1</sup> / <sub>4</sub> )	240 (9 <sup>1</sup> / <sub>2</sub> )	37	38	290 (11 <sup>1</sup> / <sub>2</sub> )	32	32
190 (7 <sup>1</sup> / <sub>2</sub> )	230 (9)	39	34	280 (11)	34	10
195 (7 <sup>3</sup> / <sub>4</sub> )	220 (8 <sup>1</sup> / <sub>2</sub> )	41	33	270 (10 <sup>1</sup> / <sub>2</sub> )	35	50
205 (8)	200 (8)	45	42	250 (10)	39	21
210 (8 <sup>1</sup> / <sub>4</sub> )	190 (7 <sup>1</sup> / <sub>2</sub> )	47	52	240 (9 <sup>1</sup> / <sub>2</sub> )	41	11
215 (8 <sup>1</sup> / <sub>2</sub> )	—	—	—	230 (9)	43	4
220 (8 <sup>3</sup> / <sub>4</sub> )	—	—	—	220 (8 <sup>1</sup> / <sub>2</sub> )	45	0
225 (9)	—	—	—	210 (8)	46	58

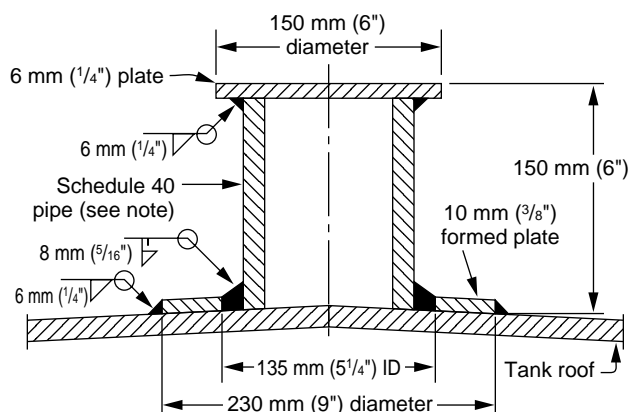

Note: NPS 4 Schedule 40 pipe [wall thickness = 6.02 mm (0.237 in.); outside diameter = 114.3 mm (4.5 in.)].

Figure 3-19—Scaffold Cable Support

**3.9.7.4** If half the height of the transformed shell exceeds the maximum height  $H_1$ , a second intermediate girder shall be used to reduce the height of unstiffened shell to a height less than the maximum.

**3.9.7.5** Intermediate wind girders shall not be attached to the shell within 150 mm (6 in.) of a horizontal joint of the shell. When the preliminary location of a girder is within 150 mm (6 in.) of a horizontal joint, the girder shall preferably be located 150 mm (6 in.) below the joint; however, the maximum unstiffened shell height shall not be exceeded.

● **3.9.7.6** The required minimum section modulus of an intermediate wind girder shall be determined by the following equation:

In SI units:

$$Z = \frac{D^2 H_1}{17}$$

where

$Z$  = required minimum section modulus (cm<sup>3</sup>),

$D$  = nominal tank diameter (m),

$H_1$  = vertical distance (m), between the intermediate wind girder and the top angle of the shell or the top wind girder of an open-top tank.

In US Customary units:

$$Z = 0.0001 D^2 H_1$$

where

$Z$  = required minimum section modulus (in.<sup>3</sup>),

$D$  = nominal tank diameter (ft),

$H_1$  = vertical distance (ft), between the intermediate wind girder and the top angle of the shell or the top wind girder of an open-top tank.

Note: This equation is based on a wind velocity of 160 km/h (100 mph). If specified by the purchaser, other wind velocities may be used by multiplying the right side of the equation by  $(V/160 \text{ km/h})^2$ , where  $V$  equals the wind velocity in km/h [ $(V/100 \text{ mph})^2$ , where  $V$  equals the wind velocity in mph]. (A description of the loads on the tank shell that are included in the 160 km/h (100 mph) design wind velocity can be found in item a of the note to 3.9.7.1.]

**3.9.7.6.1** Where the use of a transformed shell permits the intermediate wind girder to be located at a height that is less than  $H_1$  calculated by the formula in 3.9.7.1, the spacing to the mid-height of the transformed shell, transposed to the height of the actual shell, may be substituted for  $H_1$  in the calculation for the minimum section modulus if the girder is attached at the transposed location.

**3.9.7.6.2** The section modulus of the intermediate wind girder shall be based on the properties of the attached members and may include a portion of the tank shell for a distance, in mm (in.), of

In SI units:

$$00 \quad 13.4 (Dt)^{0.5}$$

where

$D$  = nominal tank diameter (m),

$t$  = shell thickness at the attachment (mm).

In US Customary units:

$$00 \quad 1.47 (Dt)^{0.5}$$

where

$D$  = nominal tank diameter (ft),

$t$  = shell thickness at the attachment (in.).

- **3.9.7.7** An opening for a stairway in an intermediate stiffener is unnecessary when the intermediate stiffener extends no more than 150 mm (6 in.) from the outside of the shell and the nominal stairway width is at least 600 mm (24 in.). For greater outward extensions of a stiffener, the stairway shall be increased in width to provide a minimum clearance of 450 mm (18 in.) between the outside of the stiffener and the hand-rail of the stairway, subject to the purchaser's approval. If an opening is necessary, it may be designed in a manner similar to that specified in 3.9.6.3 for a top wind girder with the exception that only a 450 mm (18 in.) width through the stiffener need be provided.

## 3.10 ROOFS

### 3.10.1 Definitions

The following definitions apply to roof designs but shall not be considered as limiting the type of roof permitted by 3.10.2.7:

a. A supported cone roof is a roof formed to approximately the surface of a right cone that is supported principally either by rafters on girders and columns or by rafters on trusses with or without columns.

b. A self-supporting cone roof is a roof formed to approximately the surface of a right cone that is supported only at its periphery.

c. A self-supporting dome roof is a roof formed to approximately a spherical surface that is supported only at its periphery.

d. A self-supporting umbrella roof is a modified dome roof formed so that any horizontal section is a regular polygon with as many sides as there are roof plates that is supported only at its periphery.

### 3.10.2 General

**3.10.2.1** All roofs and supporting structures shall be designed to support dead load plus a uniform live load of not less than 1.2 kPa (25 lbf/ft<sup>2</sup>) of projected area.

- **3.10.2.2** Roof plates shall have a minimum nominal thickness of 5 mm (<sup>3</sup>/<sub>16</sub> in.) 7-gauge sheet. Thicker roof plates may be required for self-supporting roofs (see 3.10.5 and 3.10.6). Any required corrosion allowance for the plates of self-supporting roofs shall be added to the calculated thickness unless otherwise specified by the purchaser. Any corrosion allowance for the plates of supported roofs shall be added to the minimum nominal thickness.

**3.10.2.3** Roof plates of supported cone roofs shall not be attached to the supporting members.

- **3.10.2.4** All internal and external structural members shall have a minimum nominal thickness of 4.3 mm (0.17 in.) in any component. The method of providing a corrosion allowance, if any, for the structural members shall be a matter of agreement between the purchaser and the manufacturer.

**3.10.2.5** Roof plates shall be attached to the top angle of the tank with a continuous fillet weld on the top side only.

**3.10.2.5.1** If the continuous fillet weld between the roof plates and the top angle does not exceed 5 mm (<sup>3</sup>/<sub>16</sub> in.), the slope of the roof at the top-angle attachment does not exceed 50 mm in 300 mm (2 in. in 12 in.), the shell-to-roof compression-ring details are limited to those shown in Details a–d of Figure F-2, and the cross-sectional area of the roof-to-shell junction,  $A$ , is less than or equal to the value calculated in 3.10.2.5.3, then the roof-to-shell joint may be considered frangible and in the event of excessive internal pressure may fail before failure occurs in the tank-shell joints or the shell-to-bottom joint. Failure of the roof-to-shell joint is usually initiated by buckling of the top angle and followed by tearing of the 5 mm (<sup>3</sup>/<sub>16</sub> in.) continuous weld of the periphery of the roof plates.

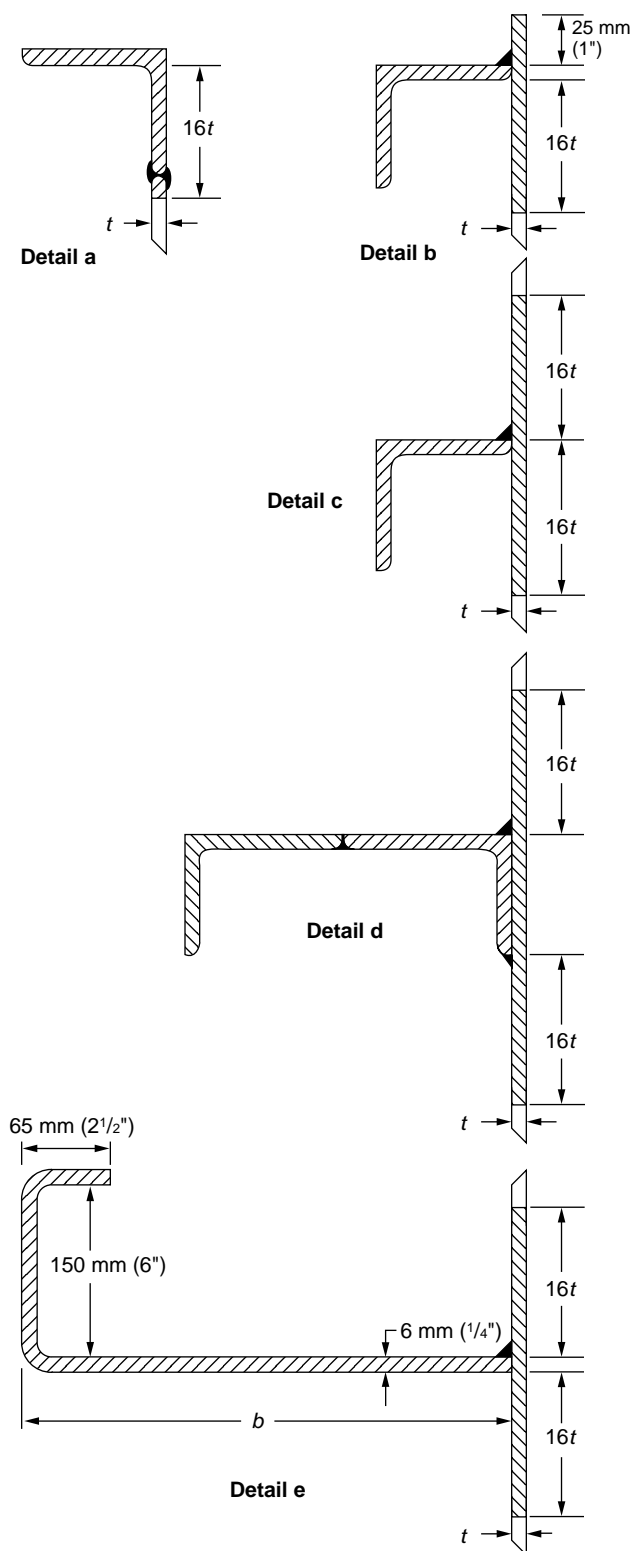

Note: The section moduli given in Table 3-20 for Details c and d are based on the longer leg being located horizontally (perpendicular to the shell) when angles with uneven legs are used.

**3.10.2.5.2 Deleted**

- **3.10.2.5.3** When a frangible joint is specified by the purchaser, the cross-sectional area of the roof-to-shell junction, A, shall not exceed the following:

In SI units:

$$A = \frac{W}{1390 \tan \theta}$$

In US Customary units:

$$A = \frac{W}{201,000 \tan \theta}$$

Note: The terms for the equation above are defined in Appendix F.

All members in the region of the roof-to-shell junction, including insulation rings, shall be considered as contributing to the cross-sectional area. When a frangible joint is specified, the top angle may be smaller than that required by item e of 3.1.5.9.

**3.10.2.6** For all types of roofs, the plates may be stiffened by sections welded to the plates but may not be stiffened by sections welded to the supporting rafters or girders.

- **3.10.2.7** These rules cannot cover all details of tank roof design and construction. With the approval of the purchaser, the roof need not comply with 3.10.4, 3.10.5, 3.10.6, and 3.10.7. The manufacturer shall provide a roof designed and constructed to be as safe as otherwise provided for in this standard. In the roof design, particular attention should be given to preventing failure through instability.
- **3.10.2.8** When the purchaser specifies lateral loads that will be imposed on the roof-supporting columns, the columns must be proportioned to meet the requirements for combined axial compression and bending as specified in 3.10.3.

**3.10.3 Allowable Stresses**

- **3.10.3.1 General**

All parts of the roof structure shall be proportioned so that the sum of the maximum static and dynamic stresses shall not exceed the limitations specified in the AISC *Specification for Structural Steel Buildings* or with the agreement of the purchaser an equivalent structural design code recognized by the government of the country where the tank is located. The portion of the specification, "Allowable Stress Design," shall be used in determining allowable unit stresses. Use of Part 5, Chapter N—"Plastic Design," is specifically not allowed.

Figure 3-20—Typical Stiffening-Ring Sections for Tank Shells (See Table 3-20)

Table 3-20—Section Moduli [ $\text{cm}^3$  ( $\text{in.}^3$ )] of Stiffening-Ring Sections on Tank Shells

Column 1		Column 2	Column 3	Column 4	Column 5	Column 6
Member Size		Shell Thickness [mm (in.)]				
mm	in.	5 ( $3/16$ )	6 ( $1/4$ )	8 ( $5/16$ )	10 ( $3/8$ )	11 ( $7/16$ )
<b>01</b>		Top Angle: Figure 3-20, Detail a				
64 × 64 × 6.4	$2\frac{1}{2} \times 2\frac{1}{2} \times \frac{1}{4}$	6.86 (0.41)	7.01 (0.42)	—	—	—
64 × 64 × 7.9	$2\frac{1}{2} \times 2\frac{1}{2} \times \frac{5}{16}$	8.30 (0.51)	8.48 (0.52)	—	—	—
76 × 76 × 9.5	$3 \times 3 \times \frac{3}{8}$	13.80 (0.89)	14.10 (0.91)	—	—	—
<b>01</b>		Curb Angle: Figure 3-20, Detail b				
64 × 64 × 6.4	$2\frac{1}{2} \times 2\frac{1}{2} \times \frac{1}{4}$	27.0 (1.61)	28.3 (1.72)	—	—	—
64 × 64 × 7.9	$2\frac{1}{2} \times 2\frac{1}{2} \times \frac{1}{16}$	31.1 (1.89)	32.8 (2.04)	—	—	—
76 × 76 × 6.4	$3 \times 3 \times \frac{1}{4}$	38.1 (2.32)	39.9 (2.48)	—	—	—
76 × 76 × 9.5	$3 \times 3 \times \frac{3}{8}$	43.0 (2.78)	52.6 (3.35)	—	—	—
102 × 102 × 6.4	$4 \times 4 \times \frac{1}{4}$	57.6 (3.64)	71.4 (4.41)	—	—	—
102 × 102 × 9.5	$4 \times 4 \times \frac{3}{8}$	65.6 (4.17)	81.4 (5.82)	—	—	—
<b>01</b>		One Angle: Figure 3-20, Detail c (See Note)				
64 × 64 × 6.4	$2\frac{1}{2} \times 2\frac{1}{2} \times \frac{1}{4}$	28.5 (1.68)	29.6 (1.79)	31.3 (1.87)	32.7 (1.93)	33.4 (2.00)
64 × 64 × 7.9	$2\frac{1}{2} \times 2\frac{1}{2} \times \frac{5}{16}$	33.1 (1.98)	34.6 (2.13)	36.9 (2.23)	38.7 (2.32)	39.5 (2.40)
102 × 76 × 6.4	$4 \times 3 \times \frac{1}{4}$	58.3 (3.50)	60.8 (3.73)	64.2 (3.89)	66.6 (4.00)	67.7 (4.10)
102 × 76 × 7.9	$4 \times 3 \times \frac{5}{16}$	68.3 (4.14)	71.6 (4.45)	76.2 (4.66)	79.4 (4.82)	80.8 (4.95)
127 × 76 × 7.9	$5 \times 3 \times \frac{5}{16}$	90.7 (5.53)	95.2 (5.96)	102.0 (6.25)	106.0 (6.47)	108.0 (6.64)
127 × 89 × 7.9	$5 \times 3\frac{1}{2} \times \frac{5}{16}$	101.0 (6.13)	106.0 (6.60)	113.0 (6.92)	118.0 (7.16)	120.0 (7.35)
127 × 89 × 9.5	$5 \times 3\frac{1}{2} \times \frac{3}{8}$	116.0 (7.02)	122.0 (7.61)	131.0 (8.03)	137.0 (8.33)	140.0 (8.58)
152 × 102 × 9.5	$6 \times 4 \times \frac{3}{8}$	150.0 (9.02)	169.0 (10.56)	182.0 (11.15)	191.0 (11.59)	194.0 (11.93)
<b>01</b>		Two Angles: Figure 3-20, Detail d (See Note)				
102 × 76 × 7.9	$4 \times 3 \times \frac{5}{16}$	186 (11.27)	191 (11.78)	200 (12.20)	207 (12.53)	210 (12.81)
102 × 76 × 9.5	$4 \times 3 \times \frac{3}{8}$	216 (13.06)	222 (13.67)	233 (14.18)	242 (14.60)	245 (14.95)
127 × 76 × 7.9	$5 \times 3 \times \frac{5}{16}$	254 (15.48)	262 (16.23)	275 (16.84)	285 (17.34)	289 (17.74)
127 × 76 × 9.5	$5 \times 3 \times \frac{3}{8}$	296 (18.00)	305 (18.89)	321 (19.64)	333 (20.26)	338 (20.77)
127 × 89 × 7.9	$5 \times 3\frac{1}{2} \times \frac{5}{16}$	279 (16.95)	287 (17.70)	300 (18.31)	310 (18.82)	314 (19.23)
127 × 89 × 9.5	$5 \times 3\frac{1}{2} \times \frac{3}{8}$	325 (19.75)	334 (20.63)	350 (21.39)	363 (22.01)	368 (22.54)
152 × 102 × 9.5	$6 \times 4 \times \frac{3}{8}$	456 (27.74)	468 (28.92)	489 (29.95)	507 (30.82)	514 (31.55)
<b>01</b>		Formed Plate: Figure 3-20, Detail e				
b = 250	b = 10	—	341 (23.29)	375 (24.63)	392 (25.61)	399 (26.34)
b = 300	b = 12	—	427 (29.27)	473 (31.07)	496 (32.36)	505 (33.33)
b = 350	b = 14	—	519 (35.49)	577 (37.88)	606 (39.53)	618 (40.78)
b = 400	b = 16	—	615 (42.06)	687 (45.07)	723 (47.10)	737 (48.67)
b = 450	b = 18	—	717 (48.97)	802 (52.62)	846 (55.07)	864 (56.99)
b = 500	b = 20	—	824 (56.21)	923 (60.52)	976 (63.43)	996 (65.73)
b = 550	b = 22	—	937 (63.80)	1049 (68.78)	1111 (72.18)	1135 (74.89)
b = 600	b = 24	—	1054 (71.72)	1181 (77.39)	1252 (81.30)	1280 (84.45)
b = 650	b = 26	—	1176 (79.99)	1317 (86.35)	1399 (90.79)	1432 (94.41)
b = 700	b = 28	—	1304 (88.58)	1459 (95.66)	1551 (100.65)	1589 (104.77)
b = 750	b = 30	—	1436 (97.52)	1607 (105.31)	1709 (110.88)	1752 (115.52)
b = 800	b = 32	—	1573 (106.78)	1759 (115.30)	1873 (121.47)	1921 (126.66)
b = 850	b = 34	—	1716 (116.39)	1917 (125.64)	2043 (132.42)	2096 (138.17)
b = 900	b = 36	—	1864 (126.33)	2080 (136.32)	2218 (143.73)	2276 (150.07)
b = 950	b = 38	—	2016 (136.60)	2248 (147.35)	2398 (155.40)	2463 (162.34)
b = 1000	b = 40	—	2174 (147.21)	2421 (158.71)	2584 (167.42)	2654 (174.99)

Note: The section moduli for Details c and d are based on the longer leg being located horizontally (perpendicular to the shell) when angles with uneven legs are used.

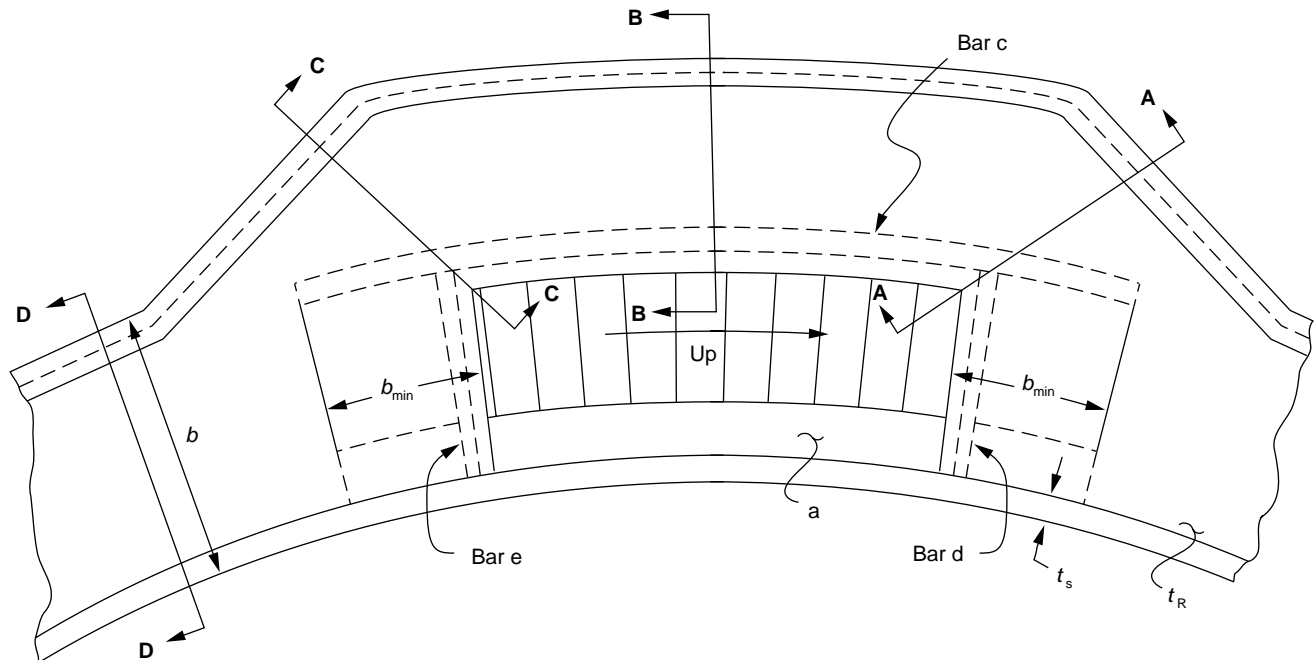

Notes:

1. The cross-sectional area of a, c, d, and e must equal  $32t_s^2$ . The section of the figure designated "a" may be a bar or an angle whose wide leg is horizontal. The other sections may be bars or angles whose wide legs are vertical.
2. Bars c, d, and e may be placed on the top of the girder web, provided they do not create a tripping hazard.
3. The section modulus of Sections A-A, B-B, C-C, and D-D shall conform to 3.9.6.1.
4. The stairway may be continuous through the wind girder or may be offset to provide a landing.
5. See 3.9.6.3 for toeboard requirements.

Figure 3-21—Stairway Opening Through Stiffening Ring

**3.10.3.2 Minimum Thicknesses**

The minimum thickness of any structural member, including any corrosion allowance on the exposed side or sides, shall not be less than 6 mm (0.250 in.) for columns, knee braces and beams or stiffeners which by design normally resist axial compressive forces or 4 mm (0.17 in.) for any other structural member.

**3.10.3.3 Maximum Slenderness Ratios**

For columns, the value  $L/r_c$  shall not exceed 180. For other compression members, the value  $L/r$  shall not exceed 200. For all other members, except tie rods whose design is based on tensile force, the value  $L/r$  shall not exceed 300.

where

- $L$  = unbraced length, mm (in.),
- $r_c$  = least radius of gyration of column, mm (in.),
- $r$  = governing radius of gyration, mm (in.).

**3.10.3.4 Columns**

When the purchaser does not specify lateral loads that will be imposed on the roof-supporting columns and the column member is not considered to be a slender element section by

the AISC Specification, the following formula for allowable compression may be used in lieu of the formulas in the AISC Specification when  $l/r$  exceeds 120 and the yield stress of column ( $F_y$ ) is less than or equal to 250 MPa (36,000 lbf/in.<sup>2</sup>).

When  $l/r$  is less than or equal to  $C_c$ :

$$F_a = \frac{\left[ \frac{\left[ 1 - \frac{(l/r)^2}{2C_c^2} \right] F_y}{\frac{5}{3} + \frac{3(l/r)}{8C_c} - \frac{(l/r)^3}{8C_c^3}} \right]}{\left[ 1.6 - \frac{l}{200r} \right]}$$

where

$$C_c = \sqrt{\frac{2\pi^2 E}{F_y}}$$

When  $l/r$  exceeds  $C_c$ :

$$F_a = \frac{\left[ \frac{12\pi^2 E}{23(l/r)^2} \right]}{\left[ 1.6 - \frac{l}{200r} \right]}$$

00

00

where

$F_a$  = allowable compression stress, MPa (lbf/in.<sup>2</sup>),

$F_y$  = yield stress of material, MPa (lbf/in.<sup>2</sup>),

$E$  = modulus of elasticity, MPa (lbf/in.<sup>2</sup>),

$l$  = unbraced length of the column, mm (in.),

$r$  = least radius of gyration of column, mm (in.).

### 3.10.4 Supported Cone Roofs

- **3.10.4.1** The slope of the roof shall be 19 mm in 300 mm (<sup>3</sup>/<sub>4</sub> in. in 12 in.) or greater if specified by the purchaser. If the rafters are set directly on chord girders, producing slightly varying rafter slopes, the slope of the flattest rafter shall conform to the specified or ordered roof slope.

**3.10.4.2** Main supporting members, including those supporting the rafters, may be rolled or fabricated sections or trusses. Although these members may be in contact with the roof plates, the compression flange of a member or the top chord of a truss shall be considered as receiving no lateral support from the roof plates and shall be laterally braced, if necessary, by other acceptable methods. The allowable stresses in these members shall be governed by 3.10.3.

- oo | **3.10.4.3** Structural members serving as rafters may be rolled or fabricated sections but in all cases shall conform to the rules of 3.10.2, 3.10.3, and 3.10.4. When considering dead loads only, including the weight of the rafters and roof plates, the compression flange of the rafter shall be considered as receiving no lateral support from the roof plates and shall be laterally braced if necessary (see 3.10.4.2). When considering dead loads plus live loads, the rafters in direct contact with the roof plates applying the live loading to the rafters may be considered as receiving adequate lateral support from the friction between the roof plates and the compression flanges of the rafters, with the following exceptions:

- Trusses and open-web joints used as rafters.
- Rafters with a nominal depth greater than 375 mm (15 in.).
- Rafters with a slope greater than 50 mm in 300 mm (2 in. in 12 in.).

- **3.10.4.4** Rafters shall be spaced so that in the outer ring, their centers are not more than 0.6π m [2π ft (6.28 ft)] apart measured along the circumference of the tank. Spacing on inner rings shall not be greater than 1.7 m (5<sup>1</sup>/<sub>2</sub> ft). When specified by the purchaser for tanks located in areas subject to earthquakes, 19 mm (<sup>3</sup>/<sub>4</sub> in.) diameter tie rods (or their equivalent) shall be placed between the rafters in the outer rings. These tie rods may be omitted if I-sections or H-sections are used as rafters.

- **3.10.4.5** Roof columns shall be made from structural shapes, or steel pipe may be used subject to the approval of

the purchaser. When pipe is used, it must be sealed, or provisions for draining and venting must be made at the purchaser's option.

**3.10.4.6** Rafter clips for the outer row of rafters shall be welded to the tank shell. Column-base clip guides shall be welded to the tank bottom to prevent lateral movement of column bases. All other structural attachments shall be bolted, riveted, or welded.

### ● 3.10.5 Self-Supporting Cone Roofs

Note: Self-supporting roofs whose roof plates are stiffened by sections welded to the plates need not conform to the minimum thickness requirements, but the thickness of the roof plates shall not be less than 5 mm (<sup>3</sup>/<sub>16</sub> in.) when so designed by the manufacturer, subject to the approval of the purchaser.

**3.10.5.1** Self-supporting cone roofs shall conform to the following requirements:

$$\theta \leq 37 \text{ degrees (slope} = 9:12)$$

$$\theta \geq 9.5 \text{ degrees (slope} = 2:12)$$

In SI units:

$$\text{Minimum thickness} = \frac{D}{4.8 \sin \theta} \geq 5 \text{ mm}$$

$$\text{Maximum thickness} = 12.5 \text{ mm, exclusive of corrosion allowance} \quad \text{oo}$$

where

$\theta$  = angle of the cone elements to the horizontal, in degrees,

$D$  = nominal diameter of the tank shell (m).

Note: When the sum of the live and dead loads exceeds 2.2 kPa, the minimum thickness shall be increased by the following ratio:

$$\sqrt{\frac{\text{live load} + \text{dead load}}{2.2 \text{ kPa}}}$$

In US Customary units:

$$\text{Minimum thickness} = \frac{D}{400 \sin \theta} \geq \frac{3}{16} \text{ in.}$$

$$\text{Maximum thickness} = \frac{1}{2} \text{ in., exclusive of corrosion allowance} \quad \text{oo}$$

where

$\theta$  = angle of the cone elements to the horizontal, in degrees,

$D$  = nominal diameter of the tank shell (ft).

Note: When the sum of the live and dead loads exceeds 45 lbf/ft<sup>2</sup>, the minimum thickness shall be increased by the following ratio:

$$\sqrt{\frac{\text{live load} + \text{dead load}}{45 \text{ lbf / ft}^2}}$$

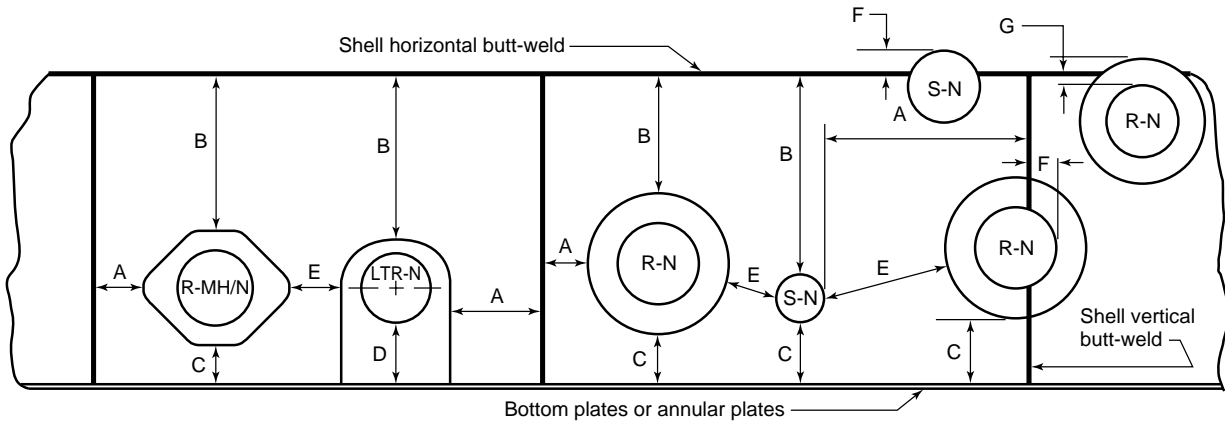

Note:

- R-MH/N = Reinforced Opening (manhole or nozzle with diamond shape reinforcing plate, see Figure 3-4A and 3-5).
- LTR-N = Low Type Reinforced Opening (nozzle with tombstone shape reinforcing plate, see Figure 3-5, Detail a and b).
- R-N = Reinforced Opening (manhole or nozzle with circular reinforcing plate or thickened insert plate, see Figure 3-5).
- S-N = Non-Reinforced Opening (manhole or nozzle inserted into the shell per the alternate neck detail of Figure 3-4B).

Variables		Reference	Minimum Dimension Between Weld Toes or Weld Centerline (1)(3)						
Shell <i>t</i>	Condition	Paragraph Number	A (2)	B (2)	C (2)	D (4)	E (2)	F (5)	G (5)
$t \leq 12.5 \text{ mm}$ ( $t \leq 1/2 \text{ in.}$ )	As welded or PWHT	3.7.3.2	150 mm (6 in.)	75 mm (3 in.) or $2^{1/2}t$	75 mm (3 in.) or $2^{1/2}t$ 75 mm (3 in.) for S-N	Table 3-6	75 mm (3 in.) or $2^{1/2}t$		
		3.7.3.3							
		3.7.3.3							
		3.7.3.3 • 3.7.3.4 • 3.7.3.4							
$t > 12.5 \text{ mm}$ ( $t > 1/2 \text{ in.}$ )	As Welded	3.7.3.1.a	8W or 250 mm (10 in.)	8W or 250 mm (10 in.)	8W or 250 mm (10 in.) 75 mm (3 in.) for S-N	Table 3-6	8W or 150 mm (6 in.)		
		3.7.3.1.b							
		3.7.3.3							
		3.7.3.3 • 3.7.3.4 • 3.7.3.4							
$t > 12.5 \text{ mm}$ ( $t > 1/2 \text{ in.}$ )	PWHT	3.7.3.2	150 mm (6 in.)	75 mm (3 in.) or $2^{1/2}t$	75 mm (3 in.) or $2^{1/2}t$ 75 mm (3 in.) for S-N	Table 3-6	75 mm (3 in.) or $2^{1/2}t$		
		3.7.3.3							
		3.7.3.3							
		3.7.3.3 • 3.7.3.4 • 3.7.3.4							

Notes:

1. If two requirements are given, the minimum spacing is the greater value, except for dimension "F". See note 5.
2. *t* = shell thickness. 8W = 8 times the largest weld size for reinforcing plate or insert plate periphery weld (fillet or butt-weld) from the toe of the periphery weld to the centerline of the shell butt-weld.
3. For tanks designed to Appendix A, see A.5.2. Spacing =  $2^{1/2}t$  toe to toe of adjacent welds.
4. *D* = spacing distance established by minimum elevation for low type reinforced openings from Table 3-6, column 9.
5. Purchaser option to allow shell openings to be located in horizontal or vertical shell butt-welds. See Figure 3-6.  
*t* = shell thickness, *r* = radius of opening. Minimum spacing for dimension *F* is the lessor of  $8t$  or  $1/2 r$ .

Figure 3-22—Minimum Weld Requirements for Openings in Shells According to Section 3.7.3

01

00

**3.10.5.2** The participating area at the roof-to-shell junction shall be determined using Figure F-2 and shall equal or exceed the following:

In SI units:

$$\frac{D^2}{0.432 \sin \theta}$$

where

$\theta$  = angle of the cone elements to the horizontal, in degrees,

$D$  = nominal diameter of the tank shell in m.

The area calculated from the expression above is based on the nominal material thickness less any corrosion allowance.

Note: When the sum of the live and dead loads exceeds 2.2 kPa, the maximum cross-sectional area of the top angle shall be increased by the following ratio:

$$\frac{\text{live load} + \text{dead load}}{2.2 \text{ kPa}}$$

In US Customary units:

$$\frac{D^2}{3000 \sin \theta}$$

where

$\theta$  = angle of the cone elements to the horizontal, in degrees,

$D$  = nominal diameter of the tank shell (ft).

The area calculated from the expression above is based on the nominal material thickness less any corrosion allowance.

Note: When the sum of the live and dead loads exceeds 45 lbf/ft<sup>2</sup>, the maximum cross-sectional area of the top angle shall be increased by the following ratio:

$$\frac{\text{live load} + \text{dead load}}{45 \text{ lbf/ft}^2}$$

### ● 3.10.6 Self-Supporting Dome and Umbrella Roofs

Note: Self-supporting roofs whose roof plates are stiffened by sections welded to the plates need not conform to the minimum thickness requirements, but the thickness of the roof plates shall not be less than 5 mm (<sup>3</sup>/<sub>16</sub> in.) when so designed by the manufacturer, subject to the approval of the purchaser.

**3.10.6.1** Self-supporting dome and umbrella roofs shall conform to the following requirements:

Minimum radius = 0.8D (unless otherwise specified by the purchaser)

Maximum radius = 1.2D

In SI units:

$$\text{Minimum thickness} = \frac{r_r}{2.4} + \text{C.A.} \geq 5 \text{ mm}$$

$$\text{Maximum thickness} = 12.5 \text{ mm, exclusive of corrosion allowance}$$

where

$D$  = nominal diameter of the tank shell,

$r_r$  = roof radius, in m.

Note: When the sum of the live and dead loads exceeds 2.2 kPa, the minimum thickness shall be increased by the following ratio:

$$\sqrt{\frac{\text{live load} + \text{dead load}}{2.2 \text{ kPa}}}$$

In US Customary units:

$$\text{Minimum thickness} = \frac{r_r}{200} + \text{C.A.} \geq \frac{3}{16} \text{ in.}$$

$$\text{Maximum thickness} = \frac{1}{2} \text{ in., exclusive of corrosion allowance.}$$

where

$D$  = nominal diameter of the tank shell (ft),

$r_r$  = roof radius, (ft).

Note: When the sum of the live and dead loads exceeds 45 lb/ft<sup>2</sup>, the minimum thickness shall be increased by the following ratio:

$$\sqrt{\frac{\text{live load} + \text{dead load}}{45 \text{ lbf/ft}^2}}$$

**3.10.6.2** The participating area, in mm<sup>2</sup>, at the roof-to-shell junction shall be determined using Figure F-2, and shall equal or exceed the following:

In SI units:

$$\frac{Dr_r}{0.216}$$

The area calculated from the expression above is based on the nominal material thickness less any corrosion allowance.

Note: When the sum of the live and dead loads exceeds 2.2 kPa, the maximum cross-sectional area of the top angle shall be increased by the following ratio:

$$\frac{\text{live load} + \text{dead load}}{2.2 \text{ kPa}}$$

In US Customary units:

The participating area, in in.<sup>2</sup>, at the roof-to-shell junction shall be determined using Figure F-2 and shall equal or exceed the following:

$$\frac{Dr_r}{1500}$$

The area calculated from the expression above is based on the nominal material thickness less any corrosion allowance.

Note: When the sum of the live and dead loads exceeds 45 lbf/ft<sup>2</sup>, the maximum cross-sectional area of the top angle shall be increased by the following ratio:

$$\frac{\text{live load} + \text{dead load}}{45 \text{ lbf/ft}^2}$$

### 3.10.7 Top-Angle Attachment for Self-Supporting Roofs

**3.10.7.1** Information and certain restrictions on types of top-angle joints are provided in item c of 3.1.5.9. Details of welding are provided in 5.2.

**3.10.7.2** At the option of the manufacturer, the edges of the roof plates for self-supporting roofs, including the cone, dome, and umbrella types, may be flanged horizontally to rest flat against the top angle to improve welding conditions.

### 3.10.8 Tank Venting

**3.10.8.1** Tanks designed in accordance with this standard and having a fixed roof shall be vented for both normal conditions (resulting from operational requirements and atmospheric changes) and emergency conditions (resulting from exposure to an external fire). Tanks with both a fixed roof and a floating roof satisfy these requirements when they comply with the circulation venting requirements of Appendix H. All other tanks designed in accordance with this standard and having a fixed roof shall meet the venting requirements of 3.10.8.2 and 3.10.8.3.

**3.10.8.2** Normal venting shall be adequate to prevent internal or external pressure from exceeding the corresponding tank design pressures and shall meet the requirements specified in API Standard 2000 for normal venting.

**3.10.8.3** Emergency venting requirements are satisfied if the tank is equipped with a weak roof-to-shell attachment (frangible joint) in accordance with 3.10.2.5, or if the tank is equipped with pressure relief devices adequate to prevent internal pressure from exceeding the tank design pressure and meeting the requirements specified in API Standard 2000 for emergency venting.

### 3.11 WIND LOAD ON TANKS (OVERTURNING STABILITY)

- **3.11.1** When specified by the purchaser, overturning stability shall be calculated using the following procedure: The wind load or pressure shall be assumed to be 1.4 kPa (30 lbf/ft<sup>2</sup>) on vertical plane surfaces, 0.86 kPa (18 lbf/ft<sup>2</sup>) on projected areas of cylindrical surfaces, and 0.72 kPa (15 lbf/ft<sup>2</sup>) on projected areas of conical and double-curved surfaces. These wind pressures are based on a wind velocity 160 km/h

(100 mph). For structures designed for wind velocities other than 160 km/h (100 mph), the wind loads specified above shall be adjusted in proportion to the following ratio:

In SI units:

$$(V / 160)^2$$

where

$V$  = wind velocity, in km/h, as specified by the purchaser.

In US Customary units:

$$(V / 100)^2$$

where

$V$  = wind velocity, in mph, as specified by the purchaser.

Note: When the wind velocity is not specified, the maximum wind velocity to avoid overturning instability shall be calculated and reported to the purchaser.

**3.11.2** For an unanchored tank, the overturning moment from wind pressure shall not exceed two-thirds of the dead-load resisting moment, excluding any tank contents, and shall be calculated as follows:

$$M \leq \frac{2}{3} \left( \frac{WD}{2} \right)$$

where

$M$  = overturning moment from wind pressure, in N-m (ft-lbf),

$W$  = shell weight available to resist uplift, less any corrosion allowance, plus dead weight supported by the shell minus simultaneous uplift from operating conditions such as internal pressure on the roof, in N (lbf),

$D$  = tank diameter, in m (ft).

**3.11.3** When anchors are required, the design tension load per anchor shall be calculated as follows:

$$t_B = \frac{4M}{dN} - \frac{W}{N}$$

where

$t_B$  = design tension load per anchor, in N (lbf),

$d$  = diameter of the anchor circle, in m (ft),

$N$  = number of anchors.

Anchors shall be spaced a maximum of 3 m (10 ft). The allowable tensile stress for anchors shall be in accordance with Appendix F.

**3.11.4** Unless otherwise required, tanks that may be subject to sliding due to wind shall use a maximum allowable sliding friction of 0.40 multiplied by the force against the tank bottom.

01



## SECTION 4—FABRICATION

### 4.1 GENERAL

#### 4.1.1 Workmanship

- **4.1.1.1** All work of fabricating API Standard 650 tanks shall be done in accordance with this standard and with the permissible alternatives specified in the purchaser's inquiry or order. The workmanship and finish shall be first class in every respect and subject to the closest inspection by the manufacturer's inspector even if the purchaser has waived any part of the inspection.

**4.1.1.2** When material requires straightening, the work shall be done by pressing or another noninjurious method prior to any layout or shaping. Heating or hammering is not permissible unless the material is maintained at forging temperature during straightening.

- **4.1.2 Finish of Plate Edges**

The edges of plates may be sheared, machined, chipped, or machine gas cut. Shearing shall be limited to plates less than or equal to 10 mm ( $\frac{3}{8}$  in.) thick used for butt-welded joints and to plates less than or equal to 16 mm ( $\frac{5}{8}$  in.) thick used for lap-welded joints.

Note: With the purchaser's approval, the shearing limitation on plates used for butt-welded joints may be increased to a thickness less than or equal to 16 mm ( $\frac{5}{8}$  in.).

When edges of plates are gas cut, the resulting surfaces shall be uniform and smooth and shall be freed from scale and slag accumulations before welding. After cut or sheared edges are wire brushed, the fine film of rust adhering to the edges need not be removed before welding. Circumferential edges of roof and bottom plates may be manually gas cut.

#### 4.1.3 Shaping of Shell Plates

Shell plates shall be shaped to suit the curvature of the tank and the erection procedure according to the following schedule:

Nominal Plate Thickness mm (in.)	Nominal Tank Diameter m (ft)
$\geq 16$ ( $\frac{5}{8}$ )	All
From 13 ( $\frac{1}{2}$ ) to $< 16$ ( $\frac{5}{8}$ )	$\leq 36$ (120)
From 10 ( $\frac{3}{8}$ ) to $< 13$ ( $\frac{1}{2}$ )	$\leq 18$ (60)
From 5 ( $\frac{3}{16}$ ) to $< 10$ ( $\frac{3}{8}$ )	$\leq 12$ (40)

#### 4.1.4 Marking

All special plates that are cut to shape before shipment as well as roof-supporting structural members shall be marked as shown on the manufacturer's drawings.

#### 4.1.5 Shipping

Plates and tank material shall be loaded in a manner that ensures delivery without damage. Bolts, nuts, nipples, and other small parts shall be boxed or put in kegs or bags for shipment.

### 4.2 SHOP INSPECTION

- **4.2.1** The purchaser's inspector shall be permitted free entry to all parts of the manufacturer's plant that are concerned with the contract whenever any work under the contract is being performed. The manufacturer shall afford the purchaser's inspector, all reasonable facilities to assure the inspector that the material is being furnished in accordance with this standard. Also, the manufacturer shall furnish, samples or specimens of materials for the purpose of qualifying welders in accordance with 7.3. |01

Unless otherwise specified, inspection shall be made at the place of manufacture prior to shipment. The manufacturer shall give the purchaser ample notice of when the mill will roll the plates and when fabrication will begin so that the purchaser's inspector may be present when required. The usual mill test of plates shall be deemed sufficient to prove the quality of the steel furnished (except as noted in 4.2.2). Mill test reports or certificates of compliance, as provided for in the material specification, shall be furnished to the purchaser only when the option is specified in the original purchase order that they be provided.

**4.2.2** Mill and shop inspection shall not release the manufacturer from responsibility for replacing any defective material and for repairing any defective workmanship that may be discovered in the field.

**4.2.3** Any material or workmanship that in any way fails to meet the requirements of this standard may be rejected by the purchaser's inspector, and the material involved shall not be used under the contract. Material that shows injurious defects subsequent to its acceptance at the mill, subsequent to its acceptance at the manufacturer's works, or during erection and testing of the tank will be rejected. The manufacturer will be notified of this in writing and will be required to furnish new material promptly and make the necessary replacements or suitable repairs.



## SECTION 5—ERECTION

### 5.1 GENERAL

- **5.1.1** The subgrade for receiving the tank bottom shall be provided by the purchaser, unless otherwise specified on the purchase order, and shall be uniform and level.

**5.1.2** The manufacturer shall furnish all labor, tools, welding equipment and cables, falsework, scaffolding, and other equipment necessary for erecting tanks that are complete and ready for use. Power for welding shall be supplied by the manufacturer unless other arrangements are stated in the purchase order.

**5.1.3** Paint or foreign material shall not be used between surfaces in contact in the construction of the tank proper, except as permitted by 5.2.1.9.

- **5.1.4** Paint or other protection for structural work inside and outside of the tank shall be as specified on the purchase order and shall be applied by competent workers.

**5.1.5** Lugs attached by welding to the exterior of the tank for the purpose of erection only shall be removed, and any noticeable projections of weld metal shall be chipped from the plate. The plate shall not be gouged or torn in the process of removing the lugs.

### 5.2 DETAILS OF WELDING

#### 5.2.1 General

- **5.2.1.1** Tanks and their structural attachments shall be welded by the shielded metal-arc, gas metal-arc, gas tungsten-arc, oxyfuel, flux-cored arc, submerged-arc, electroslag, or electrogas process using suitable equipment. Use of the oxyfuel, electroslag, or electrogas process shall be by agreement between the manufacturer and the purchaser. Use of the oxyfuel process is not permitted when impact testing of the material is required. All tank welding shall be performed in accordance with the requirements of Section 7 of this standard and welding procedure specifications as described in Section IX of the ASME Code. Welding shall be performed in a manner that ensures complete fusion with the base metal.

**5.2.1.2** No welding of any kind shall be performed when the surfaces of the parts to be welded are wet from rain, snow, or ice; when rain or snow is falling on such surfaces; or during periods of high winds unless the welder and the work are properly shielded. Also, no welding of any kind shall be performed when the temperature of the base metal is less than  $-20^{\circ}\text{C}$  ( $0^{\circ}\text{F}$ ). When the temperature of the base metal is  $-20^{\circ}\text{C}$  to  $0^{\circ}\text{C}$  ( $0^{\circ}\text{F}$  to  $32^{\circ}\text{F}$ ) or the thickness of the base metal is in excess of 32 mm ( $1\frac{1}{4}$  in.), the base metal within 75 mm (3 in.) of the place where welding is to be started shall be heated to a temperature warm to the hand (see 5.2.3.4 for preheat requirements for shell plates over 38 mm [ $1\frac{1}{2}$  in.] thick).

**5.2.1.3** Each layer of weld metal or multilayer welding shall be cleaned of slag and other deposits before the next layer is applied.

**5.2.1.4** The edges of all welds shall merge with the surface of the plate without a sharp angle. For vertical butt joints, the maximum acceptable undercutting is 0.4 mm ( $\frac{1}{64}$  in.) of the base metal. For horizontal butt joints, undercutting not exceeding 0.8 mm ( $\frac{1}{32}$  in.) in depth is acceptable.

**5.2.1.5** The reinforcement of the welds on all butt joints on each side of the plate shall not exceed the following thicknesses:

Plate Thickness mm (inches)	Maximum Reinforcement Thickness mm (in.)	
	Vertical Joints	Horizontal Joints
$\leq 13$ ( $\frac{1}{2}$ )	2.5 ( $\frac{3}{32}$ )	3 ( $\frac{1}{8}$ )
$> 13$ ( $\frac{1}{2}$ ) to 25 (1)	3 ( $\frac{1}{8}$ )	5 ( $\frac{3}{16}$ )
$> 25$ (1)	5 ( $\frac{3}{16}$ )	6 ( $\frac{1}{4}$ )

The reinforcement need not be removed except to the extent that it exceeds the maximum acceptable thickness or unless its removal is required by 6.1.3.4.

**5.2.1.6** During the welding operation, plates shall be held in close contact at all lap joints.

- **5.2.1.7** The method proposed by the manufacturer for holding the plates in position for welding shall be submitted to the purchaser's inspector for approval if approval has not already been given in writing by the purchaser.

**5.2.1.8** Tack welds used during the assembly of vertical joints of tank shells shall be removed and shall not remain in the finished joints when the joints are welded manually. When such joints are welded by the submerged-arc process, the tack welds shall be thoroughly cleaned of all welding slag but need not be removed if they are sound and are thoroughly fused into the subsequently applied weld beads.

Whether tack welds are removed or left in place, they shall be made using a fillet-weld or butt-weld procedure qualified in accordance with Section IX of the ASME Code. Tack welds to be left in place shall be made by welders qualified in accordance with Section IX of the ASME Code and shall be visually examined for defects, which shall be removed if found (see 6.5 for criteria for visual examination).

**5.2.1.9** If protective coatings are to be used on surfaces to be welded, the coatings shall be included in welding-procedure qualification tests for the brand formulation and maximum thickness of coating to be applied.

01

00

**5.2.1.10** Low-hydrogen electrodes shall be used for manual metal-arc welds, including the attachment of the first shell course to bottom or annular plates, as follows:

- a. For all welds in shell courses greater than 12.5 mm ( $1/2$  in.) thick made of material from Groups I–III.
- b. For all welds in all shell courses made of material from Groups IV–VI.

## 5.2.2 Bottoms

**5.2.2.1** After the bottom plates are laid out and tacked, they shall be joined by welding the joints in a sequence that the manufacturer has found to result in the least distortion from shrinkage and thus to provide as nearly as possible a plane surface.

**5.2.2.2** The welding of the shell to the bottom shall be practically completed before the welding of bottom joints that may have been left open to compensate for shrinkage of any welds previously made is completed.

**5.2.2.3** Shell plates may be aligned by metal clips attached to the bottom plates, and the shell may be tack welded to the bottom before continuous welding is started between the bottom edge of the shell plate and the bottom plates.

## 5.2.3 Shells

**5.2.3.1** Plates to be joined by butt welding shall be matched accurately and retained in position during the welding operation. Misalignment in completed vertical joints for plates greater than 16 mm ( $5/8$  in.) thick shall not exceed 10% of the plate thickness or 3 mm ( $1/8$  in.), whichever is less; misalignment for plates less than or equal to 16 mm ( $5/8$  in.) thick shall not exceed 1.5 mm ( $1/16$  in.).

**5.2.3.2** In completed horizontal butt joints, the upper plate shall not project beyond the face of the lower plate at any point by more than 20% of the thickness of the upper plate, with a maximum projection of 3 mm ( $1/8$  in.); however, for upper plates less than 8 mm ( $5/16$  in.) thick, the maximum projection shall be limited to 1.5 mm ( $1/16$  in.).

- **5.2.3.3** The reverse side of double-welded butt joints shall be thoroughly cleaned in a manner that will leave the exposed surface satisfactory for fusion of the weld metal to be added, prior to the application of the first bead to the second side. This cleaning may be done by chipping; grinding; melting out; or where the back of the initial bead is smooth and free from crevices that might entrap slag, another method that, upon field inspection, is acceptable to the purchaser.

**5.2.3.4** For circumferential and vertical joints in tank shell courses constructed of material more than 38 mm ( $1\frac{1}{2}$  in.) thick (based on the thickness of the thicker plate at the joint), multipass weld procedures are required, with no pass over 19 mm ( $3/4$  in.) thick permitted. A minimum preheat of 90°C (200°F) is required for these welds.

**5.2.3.5** The requirements of this section shall be followed when welding to Group IV, IVA, V, and VI materials. Permanent and temporary attachments (see 5.2.1.10 for information on shell-to-bottom welds) shall be welded with low-hydrogen electrodes. Both permanent and temporary attachments shall be welded in accordance with a procedure that minimizes the potential for underbead cracking. The need for preheat shall be considered when the procedure is selected either for welding thick plates or for welding during low atmospheric temperature. The welds of permanent attachments (not including shell-to-bottom welds) and areas where temporary attachments are removed, shall be examined visually and by either the magnetic particle method or the liquid penetrant method (see 6.2, 6.4, or 6.5 for the appropriate inspection criteria).

**5.2.3.6** Completed welds of stress-relieved assemblies shall be examined by visual, as well as by magnetic particle or penetrant methods, after stress relief, but before hydrostatic test.

**5.2.3.7** Flush-type connections shall be inspected according to 3.7.8.11.

## 5.2.4 Shell-To-Bottom Welds

- **5.2.4.1** The initial weld pass inside the shell shall have all slag and non-metals removed from the surface of the weld and then examined for its entire circumference prior to welding the first weld pass outside the shell (temporary weld fit-up tacks excepted), both visually and by one of the following methods to be agreed to by purchaser and manufacturer:

- a. Magnetic particle.
- b. Applying a solvent liquid penetrant to the weld and then applying a developer to the gap between the shell and the bottom and examining for leaks after a minimum dwell time of one hour.
- c. Applying a water soluble liquid penetrant to either side of the joint and then applying a developer to the other side of the joint and examining for leaks after a minimum dwell time of one hour.
- d. Applying a high flash point penetrating oil such as light diesel to the gap between the shell and the bottom, letting stand for at least four hours, and examining the weld for evidence of wicking.

Note: Residual oil may remain on the surfaces yet to be welded even after the cleaning required below and contamination of the subsequent weld is possible.

- e. Applying a bubble-forming solution to the weld, using a right angle vacuum box, and examining for bubbles.

Thoroughly clean all residual examination materials from the as yet to be welded surfaces and from the unwelded gap between the shell and bottom. Remove defective weld segments and reweld as required. Reexamine the repaired welds

01

00

01

01

and a minimum of 150 mm (6 in.) to either side in the manner described above. Repeat this clean-remove-repair-examine-and-clean process until there is no evidence of leaking. Complete all welding passes of the joint both inside and outside the shell. Visually examine the finished weld surfaces of the joint both inside and outside the shell for their entire circumference.

**5.2.4.2** As an alternative to 5.2.4.1, the initial weld passes, inside and outside of the shell, shall have all slag and non-metals removed from the surface of the welds and the welds shall be examined visually. Additionally, after the completion of the inside and outside fillet or partial penetration welds, the welds may be tested by pressurizing the volume between the inside and outside welds with air pressure to 103 kPa (15 lbf/in.<sup>2</sup> gauge) and applying a solution film to both welds. To assure that the air pressure reaches all parts of the welds, a sealed blockage in the annular passage between the inside and outside welds must be provided by welding at one or more points. Additionally, a small pipe coupling communicating with the volume between the welds must be connected at one end and a pressure gauge connected to a coupling on the other end of the segment under test.

**5.2.4.3** By agreement between the purchaser and the manufacturer, the examinations of 5.2.4.1 may be waived if the following examinations are performed on the entire circumference of the weld(s):

- a. Visually examine the initial weld pass (inside or outside).
- b. Visually examine the finished joint welded surfaces, both inside and outside the shell.
- c. Examine either side of the finished joint weld surfaces by magnetic particle, or liquid penetrant, or right angle vacuum box.

## 5.2.5 Roofs

Except for the stipulation that the structural framing (such as the rafters and girders) of the roof must be reasonably true to line and surface, this standard does not include special stipulations for erection of the roof.

## 5.3 INSPECTION, TESTING, AND REPAIRS

### 5.3.1 General

**5.3.1.1** The purchaser's inspector shall at all times have free entry to all parts of the job while work under the contract is being performed. The manufacturer shall afford the purchaser's inspector reasonable facilities to assure the inspector that the work is being performed in accordance with this standard.

**5.3.1.2** Any material or workmanship shall be subject to the replacement requirements of 4.2.3.

**5.3.1.3** Material that is damaged by defective workmanship or that is otherwise defective will be rejected. The manufacturer will be notified of this in writing and will be required to furnish new material promptly or to correct defective workmanship.

**5.3.1.4** Before acceptance, all work shall be completed to the satisfaction of the purchaser's inspector, and the entire tank, when filled with oil, shall be tight and free from leaks.

### 5.3.2 Inspection of Welds

#### 5.3.2.1 Butt-Welds

Complete penetration and complete fusion are required for welds joining shell plates to shell plates. Inspection for the quality of the welds shall be made using the radiographic method specified in 6.1 and using the visual method. In addition, the purchaser's inspector may visually inspect all butt-welds for cracks, arc strikes, excessive undercuts, surface porosity, incomplete fusion, and other defects. Acceptance and repair criteria for the visual method are specified in 6.5.

#### 5.3.2.2 Fillet Welds

Fillet welds shall be inspected by the visual method. The final weld shall be cleaned of slag and other deposits prior to inspection. Visual examination acceptance and repair criteria are specified in 6.5.

#### 5.3.2.3 Responsibility

The manufacturer shall be responsible for making radiographs and any necessary repairs; however, if the purchaser's inspector requires radiographs in excess of the number specified in Section 6, or requires chip-outs of fillet welds in excess of one per 30 m (100 ft) of weld and no defect is disclosed, the additional inspections and associated work shall be the responsibility of the purchaser.

### 5.3.3 Examination and Testing of the Tank Bottom

Upon completion of welding of the tank bottom, the bottom welds and plates shall be examined visually for any potential defects and leaks. Particular attention shall apply to areas such as sumps, dents, gouges, three-plate laps, bottom plate breakdowns, arc strikes, temporary attachment removal areas, and welding lead arc burns. Visual examination acceptance and repair criteria are specified in 6.5. In addition, all welds shall be tested by one of the following methods:

- a. A vacuum box test in accordance with 6.6.
- b. A tracer gas test in accordance with 6.6.11.
- c. After at least the lowest shell course has been attached to the bottom, water (to be supplied by the purchaser) shall be pumped underneath the bottom. A head of 150 mm (6 in.) of liquid shall be maintained using a temporary dam to hold that

depth around the edge of the bottom. The line containing water for testing may be installed temporarily by running it through a manhole to one or more temporary flange connections in the bottom of the tank, or the line may be installed permanently in the subgrade beneath the tank. The method of installation should be governed by the nature of the subgrade. Reasonable care shall be taken to preserve the prepared subgrade under the tank.

### 5.3.4 Inspection of Reinforcement-Plate Welds

After fabrication is completed but before the tank is filled with test water, the reinforcement plates shall be tested by applying up to 100 kPa (15 lbf/in.<sup>2</sup>) gauge pneumatic pressure between the tank shell and the reinforcement plate on each opening using the tell-tale hole specified in 3.7.5.1. While each space is subjected to such pressure, a soap film, linseed oil, or another material suitable for the detection of leaks shall be applied to all attachment welding around the reinforcement, both inside and outside the tank.

### 01 | ● 5.3.5 Testing of the Shell

After the entire tank is completed but before any permanent external piping is connected to the tank, the shell (except for the shell of tanks designed in accordance with Appendix F) shall be tested by one of the following methods:

a. If water is available for testing the shell, the tank shall be filled with water as follows: (1) to the maximum design liquid level, *H*; (2) for a tank with a tight roof, to 50 mm (2 in.) above the weld connecting the roof plate or compression bar to the top angle or shell; or (3) to a level lower than that specified in subitem 1 or 2 when restricted by overflows, an internal floating roof, or other freeboard by agreement between the purchaser and the manufacturer. The tank shall be inspected frequently during the filling operation, and any welded joints above the test-water level shall be examined in accordance with item b.

b. If sufficient water to fill the tank is not available, the tank may be tested by (1) painting all of the joints on the inside with a highly penetrating oil, such as automobile spring oil, and carefully examining the outside of the joints for leakage; (2) applying vacuum to either side of the joints or applying internal air pressure as specified for the roof test in 5.3.6 and carefully examining the joints for leakage; or (3) using any

combination of the methods stipulated in 5.3.5.b, subitems 1 and 2.

### 5.3.6 Testing of the Roof

**5.3.6.1** Upon completion, the roof of a tank designed to be gastight (except for roofs designed under 5.3.6.2, F.4.4, and F.7.6) shall be tested by one of the following methods:

a. Applying internal air pressure not exceeding the weight of the roof plates and applying to the weld joints a soap solution or other material suitable for the detection of leaks.

b. Vacuum testing the weld joints in accordance with 6.6 to detect any leaks.

- **5.3.6.2** Upon completion, the roof of a tank not designed to be gastight, such as a tank with peripheral circulation vents or a tank with free or open vents, shall receive only visual inspection of its weld joints, unless otherwise specified by the purchaser.

### 5.4 REPAIRS TO WELDS

**5.4.1** All defects found in welds shall be called to the attention of the purchaser's inspector, and the inspector's approval shall be obtained before the defects are repaired. All completed repairs shall be subject to the approval of the purchaser's inspector. Acceptance criteria are specified in 6.2, 6.4, and 6.5, as applicable.

**5.4.2** Pinhole leaks or porosity in a tank bottom joint may be repaired by applying an additional weld bead over the defective area. Other defects or cracks in tank bottom or tank roof (including floating roofs in Appendix C) joints shall be repaired as required by 6.1.7. Mechanical caulking is not permitted.

**5.4.3** All defects, cracks, or leaks in shell joints or the shell-to-bottom joint shall be repaired in accordance with 6.1.7.

- **5.4.4** Repairs of defects discovered after the tank has been filled with water for testing shall be made with the water level at least 0.3 m (1 ft) below any point being repaired or, if repairs have to be made on or near the tank bottom, with the tank empty. Welding shall not be done on any tank unless all connecting lines have been completely blinded. Repairs shall not be attempted on a tank that is filled with oil or that has contained oil until the tank has been emptied, cleaned, and

gas freed. Repairs on a tank that has contained oil shall not be attempted by the manufacturer unless the manner of repair has been approved in writing by the purchaser and the repairs are made in the presence of the purchaser's inspector.

## 5.5 DIMENSIONAL TOLERANCES

### ● 5.5.1 General

The purpose of the tolerances given in 5.5.2 through 5.5.6 is to produce a tank of acceptable appearance and to permit proper functioning of floating roofs. These tolerances may be waived by agreement between the purchaser and the manufacturer.

### 5.5.2 Plumbness

98 | The maximum out-of-plumbness of the top of the shell relative to the bottom of the shell shall not exceed  $1/200$  of the total tank height. The out-of-plumbness in one shell course shall not exceed the permissible variations for flatness and waviness as specified in ASTM A 6M/A 6, ASTM A 20M/A 20, or ASTM A 480M/A 480, whichever is applicable. 98 | The  $1/200$  criteria shall also apply to fixed roof columns. For tanks with internal floating roofs, apply the criteria of this section or Appendix H, whichever is more stringent.

### 5.5.3 Roundness

Radii measured at 0.3 m (1 ft) above the bottom corner weld shall not exceed the following tolerances:

Tank Diameter m (ft)	Radius Tolerance mm (in.)
< 12 (40)	$\pm 13$ ( $1/2$ )
From 12 (40) to < 45 (150)	$\pm 19$ ( $3/4$ )
From 45 (150) to < 75 (250)	$\pm 25$ (1)
$\geq 75$ (250)	$\pm 32$ ( $1\frac{1}{4}$ )

### 5.5.4 Local Deviations

Local deviations from the theoretical shape (for example, weld discontinuities and flat spots) shall be limited as follows:

- Deviations (peaking) at vertical weld joints shall not exceed 13 mm ( $1/2$  in.). Peaking at vertical weld joints shall be determined using a horizontal sweep board 900 mm (36 in.) long. The sweep board shall be made to the nominal radius of the tank.
- Deviations (banding) at horizontal weld joints shall not exceed 13 mm ( $1/2$  in.). Banding at horizontal weld joints

shall be determined using a straight edge vertical sweep board 900 mm (36 in.) long.

c. Flat spots measured in the vertical plane shall not exceed the appropriate plate flatness and waviness requirements given in 5.5.2.

### 5.5.5 Foundations

**5.5.5.1** To achieve the tolerances specified above, it is essential that a foundation true to the plane be provided for the tank erection. The foundation should have adequate bearing to maintain the trueness of the foundation (see Appendix B).

**5.5.5.2** Where foundations true to a horizontal plane are specified, tolerances shall be as follows:

- Where a concrete ringwall is provided under the shell, the top of the ringwall shall be level within  $\pm 3$  mm ( $1/8$  in.) in any 9 m (30 ft) of the circumference and within  $\pm 6$  mm ( $1/4$  in.) in the total circumference measured from the average elevation.
- Where a concrete ringwall is not provided, the foundation under the shell shall be level within  $\pm 3$  mm ( $1/8$  in.) in any 3 m (10 ft) of the circumference and within  $\pm 13$  mm ( $1/2$  in.) in the total circumference measured from the average elevation.
- Where a concrete slab foundation is provided, the first 0.3 m (1 ft) of the foundation (or width of the annular ring), measured from the outside of the tank radially towards the center, shall comply with the concrete ringwall requirement. The remainder of the foundation shall be within  $\pm 13$  mm ( $1/2$  in.) of the design shape.

**5.5.5.3** Where a sloping foundation is specified, elevation differences about the circumference shall be calculated from the specified high point. Actual elevation differences about the circumference shall be determined from the actual elevation of the specified high point. The actual elevation differences shall not deviate from the calculated differences by more than the following tolerances:

- Where a concrete ringwall is provided,  $\pm 3$  mm ( $1/8$  in.) in any 9 m (30 ft) of circumference and  $\pm 6$  mm ( $1/4$  in.) in the total circumference.
- Where a concrete ringwall is not provided,  $\pm 3$  mm ( $1/8$  in.) in any 3 m (10 ft) of circumference and  $\pm 13$  mm ( $1/2$  in.) in the total circumference.

### 5.5.6 Measurements

Measurements shall be taken prior to the water test.



## SECTION 6—METHODS OF INSPECTING JOINTS

Note: In this standard, the term inspector, as used in Sections V and VIII of the ASME Code, shall be interpreted to mean the purchaser's inspector.

### 6.1 RADIOGRAPHIC METHOD

For the purposes of this paragraph, plates shall be considered of the same thickness when the difference in their specified or design thickness does not exceed 3 mm ( $1/8$  in.).

#### 6.1.1 Application

Radiographic inspection is required for shell butt-welds (see 6.1.2.2 and 6.1.2.3), annular-plate butt-welds (see 6.1.2.9), and flush-type connections with butt-welds (see 3.7.8.11). Radiographic inspection is not required for the following: roof-plate welds, bottom-plate welds, welds joining the top angle to either the roof or shell, welds joining the shell plate to the bottom plate, welds in nozzle and manway necks made from plate, or appurtenance welds to the tank.

#### 6.1.2 Number and Location of Radiographs

**6.1.2.1** Except when omitted under the provisions of A.3.4, radiographs shall be taken as specified in 6.1.2 through 6.1.8.

**6.1.2.2** The following requirements apply to vertical joints:

a. For butt-welded joints in which the thinner shell plate is less than or equal to 10 mm ( $3/8$  in.) thick, one spot radiograph shall be taken in the first 3 m (10 ft) of completed vertical joint of each type and thickness welded by each welder or welding operator. The spot radiographs taken in the vertical joints of the lowest course may be used to meet the requirements of Note 3 in Figure 6-1 for individual joints. Thereafter, without regard to the number of welders or welding operators, one additional spot radiograph shall be taken in each additional 30 m (100 ft) (approximately) and any remaining major fraction of vertical joint of the same type and thickness. At least 25% of the selected spots shall be at junctions of vertical and horizontal joints, with a minimum of two such intersections per tank. In addition to the foregoing requirements, one random spot radiograph shall be taken in each vertical joint in the lowest course (see the top panel of Figure 6-1).

b. For butt-welded joints in which the thinner shell plate is greater than 10 mm ( $3/8$  in.) but less than or equal to 25 mm (1 in.) in thickness, spot radiographs shall be taken according to item a. In addition, all junctions of vertical and horizontal joints in plates in this thickness range shall be radiographed; each film shall clearly show not less than 75 mm (3 in.) of vertical weld and 50 mm (2 in.) of weld length on each side of the vertical intersection. In the lowest course, two spot radiographs shall be taken in each vertical joint: one of the radiographs shall be as close to the bottom as is practicable,

and the other shall be taken at random (see the center panel of Figure 6-1).

c. Vertical joints in which the shell plates are greater than 25 mm (1 in.) thick shall be fully radiographed. All junctions of vertical and horizontal joints in this thickness range shall be radiographed; each film shall clearly show not less than 75 mm (3 in.) of vertical weld and 50 mm (2 in.) of weld length on each side of the vertical intersection (see the bottom panel of Figure 6-1).

d. The butt-weld around the periphery of an insert manhole or nozzle shall be completely radiographed.

**6.1.2.3** One spot radiograph shall be taken in the first 3 m (10 ft) of completed horizontal butt joint of the same type and thickness (based on the thickness of the thinner plate at the joint) without regard to the number of welders or welding operators. Thereafter, one radiograph shall be taken in each additional 60 m (200 ft) (approximately) and any remaining major fraction of horizontal joint of the same type and thickness. These radiographs are in addition to the radiographs of junctions of vertical joints required by item c of 6.1.2.2 (see Figure 6-1).

**6.1.2.4** When two or more tanks are erected in the same location for the same purchaser, either concurrently or serially, the number of spot radiographs to be taken may be based on the aggregate length of welds of the same type and thickness in each group of tanks rather than the length in each individual tank.

**6.1.2.5** It should be recognized that the same welder or welding operator may not weld both sides of the same butt joint. If two welders or welding operators weld opposite sides of the same butt joint, it is permissible to inspect their work with one spot radiograph. If the spot radiograph is rejected, further spot radiographs shall be taken to determine whether one or both of the welders or welding operators are at fault.

**6.1.2.6** An equal number of spot radiographs shall be taken from the work of each welder or welding operator in proportion to the length of joints welded.

● **6.1.2.7** As welding progresses, radiographs shall be taken as soon as it is practicable. The locations where spot radiographs are to be taken may be determined by the purchaser's inspector.

**6.1.2.8** Each radiograph shall clearly show a minimum of 150 mm (6 in.) of weld length. The film shall be centered on the weld and shall be of sufficient width to permit adequate space for the location of identification marks and an image quality indicator (IQI) (penetrameter).

**6.1.2.9** When bottom annular plates are required by 3.5.1, or by M.4.1, the radial joints shall be radiographed as

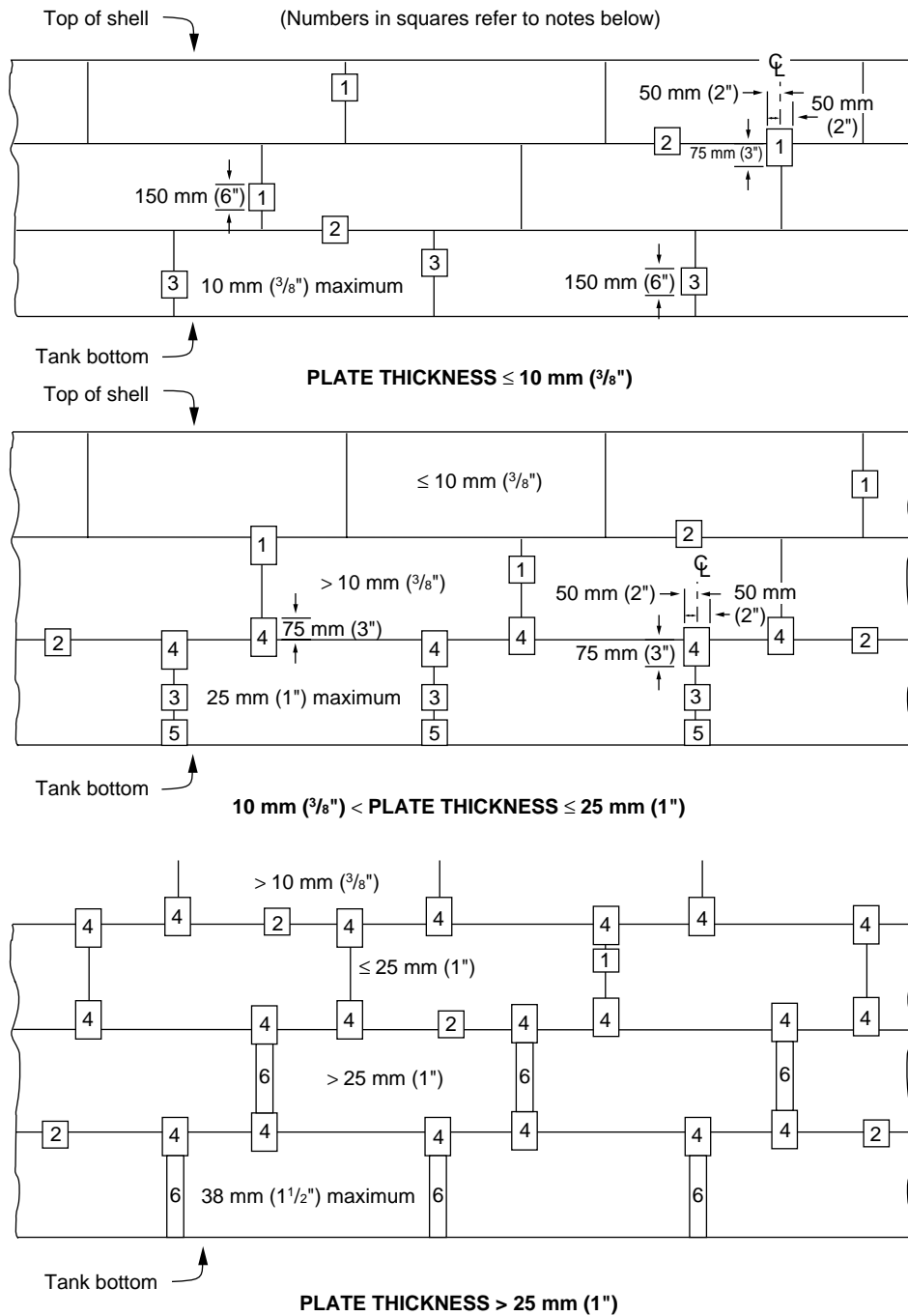

98

98

Notes:

1. Vertical spot radiograph in accordance with 6.1.2.2, item a: one in the first 3 m (10 ft) and one in each 30 m (100 ft) thereafter, 25% of which shall be at intersections.
2. Horizontal spot radiograph in accordance with 6.1.2.3: one in the first 3 m (10 ft) and one in each 60 m (200 ft) thereafter.
3. Vertical spot radiograph in each vertical seam in the lowest course (see 6.1.2.2, item b). Spot radiographs that satisfy the requirements of Note 1 for the lowest course may be used to satisfy this requirement.
4. Spot radiographs of all intersections over 10 mm (3/8 in.) (see 6.1.2.2, item b).
5. Spot radiograph of bottom of each vertical seam in lowest shell course over 10 mm (3/8 in.) (see 6.1.2.2, item b).
6. Complete radiograph of each vertical seam over 25 mm (1 in.). The complete radiograph may include the spot radiographs of the intersections if the film has a minimum width of 100 mm (4 in.) (see 6.1.2.2, item c).

00

Figure 6-1—Radiographic Requirements for Tank Shells

follows: (a) For double-welded butt joints, one spot radiograph shall be taken on 10% of the radial joints; (b) For single-welded butt joints with permanent or removable backup bar, one spot radiograph shall be taken on 50% of the radial joints. Extra care must be exercised in the interpretation of radiographs of single-welded joints that have a permanent backup bar. In some cases, additional exposures taken at an angle may determine whether questionable indications are acceptable. The minimum radiographic length of each radial joint shall be 150 mm (6 in.). Locations of radiographs shall preferably be at the outer edge of the joint where the shell-plate and annular plate join.

### 6.1.3 Technique

**6.1.3.1** Except as modified in this section, the radiographic examination method employed shall be in accordance with Section V, Article 2, of the ASME Code.

**6.1.3.2** Personnel who perform and evaluate radiographic examinations according to this section shall be qualified and certified by the manufacturer as meeting the requirements of certification as generally outlined in Level II or Level III of ASNT SNT-TC-1A (including applicable supplements). Level I personnel may be used if they are given written acceptance/rejection procedures prepared by Level II or Level III personnel. These written procedures shall contain the applicable requirements of Section V, Article 2, of the ASME Code. In addition, all Level I personnel shall be under the direct supervision of Level II or Level III personnel.

**6.1.3.3** The requirements of T-285 in Section V, Article 2, of the ASME Code are to be used only as a guide. Final acceptance of radiographs shall be based on the ability to see the prescribed image quality indicator (penetrameter) and the specified hole or wire.

**6.1.3.4** The finished surface of the weld reinforcement at the location of the radiograph shall either be flush with the plate or have a reasonably uniform crown not to exceed the following values:

01

01

00

Plate Thickness mm (in.)	Maximum Thickness of Reinforcement mm (in.)
≤ 13 (1/2)	1.5 (1/16)
> 13 (1/2) to 25 (1)	2.5 (3/32)
> 25 (1)	3 (1/8)

### 6.1.4 Submission of Radiographs

Before any welds are repaired, the radiographs shall be submitted to the inspector with any information requested by the inspector regarding the radiographic technique used.

### 6.1.5 Radiographic Standards

Welds examined by radiography shall be judged as acceptable or unacceptable by the standards of Paragraph UW-51(b) in Section VIII of the ASME Code.

### 6.1.6 Determination of Limits of Defective Welding

When a section of weld is shown by a radiograph to be unacceptable under the provisions of 6.1.5 or the limits of the deficient welding are not defined by the radiograph, two spots adjacent to the section shall be examined by radiography; however, if the original radiograph shows at least 75 mm (3 in.) of acceptable weld between the defect and any one edge of the film, an additional radiograph need not be taken of the weld on that side of the defect. If the weld at either of the adjacent sections fails to comply with the requirements of 6.1.5, additional spots shall be examined until the limits of unacceptable welding are determined, or the erector may replace all of the welding performed by the welder or welding operator on that joint. If the welding is replaced, the inspector shall have the option of requiring that one radiograph be taken at any selected location on any other joint on which the same welder or welding operator has welded. If any of these additional spots fail to comply with the requirements of 6.1.5, the limits of unacceptable welding shall be determined as specified for the initial section.

### 6.1.7 Repair of Defective Welds

**6.1.7.1** Defects in welds shall be repaired by chipping or melting out the defects from one side or both sides of the joint, as required, and rewelding. Only the cutting out of defective joints that is necessary to correct the defects is required.

- **6.1.7.2** All repaired welds in joints shall be checked by repeating the original inspection procedure and by repeating one of the testing methods of 5.3, subject to the approval of the purchaser.

### 6.1.8 Record of Radiographic Examination

**6.1.8.1** The manufacturer shall prepare an as-built radiograph map showing the location of all radiographs taken along with the film identification marks.

- **6.1.8.2** After the structure is completed, the films shall be the property of the purchaser unless otherwise agreed upon by the purchaser and the manufacturer.

## 6.2 MAGNETIC PARTICLE EXAMINATION

**6.2.1** When magnetic particle examination is specified, the method of examination shall be in accordance with Section V, Article 7, of the ASME Code.

**6.2.2** Magnetic particle examination shall be performed in accordance with a written procedure that is certified by the manufacturer to be in compliance with the applicable requirements of Section V of the ASME Code.

**6.2.3** The manufacturer shall determine that each magnetic particle examiner meets the following requirements:

- a. Has vision (with correction, if necessary) to be able to read a Jaeger Type 2 standard chart at a distance of not less than 300 mm (12 in.) and is capable of distinguishing and differentiating contrast between the colors used. Examiners shall be checked annually to ensure that they meet these requirements.
- b. Is competent in the technique of the magnetic particle examination method, including performing the examination and interpreting and evaluating the results; however, where the examination method consists of more than one operation, the examiner need only be qualified for one or more of the operations.

**6.2.4** Acceptance standards and the removal and repair of defects shall be in accordance with Section VIII, Appendix 6, Paragraphs 6-3, 6-4, and 6-5, of the ASME Code.

### 6.3 ULTRASONIC EXAMINATION

**6.3.1** When ultrasonic examination is specified, the method of examination shall be in accordance with Section V, Article 5, of the ASME Code.

**6.3.2** Ultrasonic examination shall be performed in accordance with a written procedure that is certified by the manufacturer to be in compliance with the applicable requirements of Section V of the ASME Code.

**6.3.3** Examiners who perform ultrasonic examinations under this section shall be qualified and certified by the manufacturers as meeting the requirements of certification as generally outlined in Level II or Level III of ASNT SNT-TC-1A (including applicable supplements). Level I personnel may be used if they are given written acceptance/rejection criteria prepared by Level II or Level III personnel. In addition, all Level I personnel shall be under the direct supervision of Level II or Level III personnel.

- **6.3.4** Acceptance standards shall be agreed upon by the purchaser and the manufacturer.

### 6.4 LIQUID PENETRANT EXAMINATION

**6.4.1** When liquid penetrant examination is specified, the method of examination shall be in accordance with Section V, Article 6, of the ASME Code.

**6.4.2** Liquid penetrant examination shall be performed in accordance with a written procedure that is certified by the manufacturer to be in compliance with the applicable requirements of Section V of the ASME Code.

**6.4.3** The manufacturer shall determine and certify that each liquid penetrant examiner meets the following requirements:

- a. Has vision (with correction, if necessary) to enable him to read a Jaeger Type 2 standard chart at a distance of not less than 300 mm (12 in.) and is capable of distinguishing and differentiating contrast between the colors used. Examiners shall be checked annually to ensure that they meet these requirements.
- b. Is competent in the technique of the liquid penetrant examination method for which he is certified, including making the examination and interpreting and evaluating the results; however, where the examination method consists of more than one operation, the examiner may be certified as being qualified for one or more of the operations.

**6.4.4** Acceptance standards and the removal and repair of defects shall be in accordance with Section VIII, Appendix 8, Paragraphs 8-3, 8-4, and 8-5, of the ASME Code.

### 6.5 VISUAL EXAMINATION

**6.5.1** A weld shall be acceptable by visual inspection if the inspection shows the following:

- a. There are no crater cracks, other surface cracks or arc strikes in or adjacent to the welded joints.
- b. Undercutting does not exceed the limits given in 5.2.1.4 for vertical and horizontal butt joints. For welds that attach nozzles, manholes, cleanout openings, and permanent attachments, undercutting shall not exceed 0.4 mm ( $1/64$  in.).
- c. The frequency of surface porosity in the weld does not exceed one cluster (one or more pores) in any 100 mm (4 in.) of length, and the diameter of each cluster does not exceed 2.5 mm ( $3/32$  in.).

**6.5.2** A weld that fails to meet the criteria given in 6.5.1 shall be reworked before hydrostatic testing as follows:

- a. Any defects shall be removed by mechanical means or thermal gouging processes. Arc strikes discovered in or adjacent to welded joints shall be repaired by grinding and rewelding as required. Arc strikes repaired by welding shall be ground flush with the plate.
- b. Rewelding is required if the resulting thickness is less than the minimum required for design or hydrostatic test conditions. All defects in areas thicker than the minimum shall be feathered to at least a 4:1 taper.
- c. The repair weld shall be visually examined for defects.

### 6.6 VACUUM TESTING

**6.6.1** Vacuum testing is performed using a testing box approximately 150 mm (6 in.) wide by 750 mm (30 in.) long with a clear window in the top, which provides proper visibility to view the area under inspection. During testing, illumination shall be adequate for proper evaluation and

100

101

interpretation of the test. The open bottom shall be sealed against the tank surface by a suitable gasket. Connections, valves, lighting and gauges, shall be provided as required. A soap film solution or commercial leak detection solution, applicable to the conditions, shall be used.

**6.6.2** Vacuum testing shall be performed in accordance with a written procedure prepared by the manufacturer of the tank. The procedure shall require:

- a. Performing a visual examination of the bottom and welds prior to performing the vacuum box test;
- b. Verifying the condition of the vacuum box and its gasket seals;
- c. Verifying that there is no quick bubble or spitting response to large leaks; and
- d. Applying the film solution to a dry area, such that the area is thoroughly wetted and a minimum generation of application bubbles occurs.

**6.6.3** A partial vacuum of 21 kPa (3 lbf/in.<sup>2</sup>/6 in. Hg) to 35 kPa (5 lbf/in.<sup>2</sup>/10 in. Hg) gauge shall be used for the test. If specified by the purchaser, a second partial vacuum test of 56 kPa (8 lbf/in.<sup>2</sup>/16 in. Hg) to 70 kPa (10 lbf/in.<sup>2</sup>/20 in. Hg) shall be performed for the detection of very small leaks.

**6.6.4** The manufacturer shall determine that each vacuum box operator meets the following requirements:

- a. Has vision (with correction, if necessary) to be able to read a Jaeger Type 2 standard chart at a distance of not less than 300 mm (12 in.). Operators shall be checked annually to ensure that they meet this requirement; and
- b. Is competent in the technique of the vacuum box testing, including performing the examination and interpreting and evaluating the results; however, where the examination method consists of more than one operation, the operator performing only a portion of the test need only be qualified for that portion the operator performs.

**6.6.5** The vacuum box test shall have at least 50 mm (2 in.) overlap of previously viewed surface on each application.

**6.6.6** The metal surface temperature limits shall be between 4°C (40°F) and 52°C (125°F), unless the film solution is proven to work at temperatures outside these limits, either by testing or manufacturer's recommendations.

**6.6.7** A minimum light intensity of 1000 Lux (100 fc) at the point of examination is required during the application of the examination and evaluation for leaks.

**6.6.8** The vacuum shall be maintained for the greater of either at least 5 seconds or the time required to view the area under test.

**6.6.9** The presence of a through-thickness leak indicated by continuous formation or growth of a bubble(s) or foam, produced by air passing through the thickness, is unacceptable. The presence of a large opening leak, indicated by a quick bursting bubble or spitting response at the initial setting of the vacuum box is unacceptable. Leaks shall be repaired and retested.

**6.6.10** A record or report of the test including a statement addressing temperature and light intensity shall be completed and furnished to the customer upon request.

- **6.6.11** As an alternate to vacuum box testing, a suitable tracer gas and compatible detector can be used to test the integrity of welded bottom joints for their entire length. Where tracer gas testing is employed as an alternate to vacuum box testing, it shall meet the following requirements:

a. Tracer gas testing shall be performed in accordance with a written procedure which has been reviewed and approved by the purchaser and which shall address as a minimum: the type of equipment used, surface cleanliness, type of tracer gas, test pressure, soil permeability, soil moisture content, satisfactory verification of the extent of tracer gas permeation, and the method or technique to be used including scanning rate and probe standoff distance.

b. The technique shall be capable of detecting leakage of  $1 \times 10^{-4}$  Pa m<sup>3</sup>/s ( $1 \times 10^{-3}$  std cm<sup>3</sup>/s) or smaller

c. The test system parameters (detector, gas, and system pressure, i.e. level of pressure under bottom) shall be calibrated by placing the appropriate calibrated capillary leak, which will leak at a rate consistent with (b) above, in a temporary or permanent fitting in the tank bottom away from the tracer gas pressurizing point. Alternatively, by agreement between purchaser and manufacturer, the calibrated leak may be placed in a separate fitting pressurized in accordance with the system parameters.

d. While testing for leaks in the welded bottom joints, system parameters shall be unchanged from those used during calibration.

01

01



## SECTION 7—WELDING PROCEDURE AND WELDER QUALIFICATIONS

### 7.1 DEFINITIONS

In this standard, terms relating to welding shall be interpreted as defined in Section IX of the ASME Code. Additional terms are defined in 7.1.1 and 7.1.2.

**7.1.1** An *angle joint* is a joint between two members that intersect at an angle between 0 degrees (a butt joint) and 90 degrees (a corner joint).

**7.1.2** *Porosity* refers to gas pockets or voids in metal.

### 7.2 QUALIFICATION OF WELDING PROCEDURES

#### 7.2.1 General Requirements

- **7.2.1.1** The erection manufacturer and the fabrication manufacturer, if other than the erection manufacturer, shall prepare welding procedure specifications and shall perform tests documented by procedure qualification records to support the specifications, as required by Section IX of the ASME Code and any additional provisions of this standard. If the manufacturer is part of an organization that has, to the purchaser's satisfaction, established effective operational control of the qualification of welding procedures and of welder performance for two or more companies of different names, then separate welding procedure qualifications are not required, provided all other requirements of 7.2, 7.3, and Section IX of the ASME Code are met.

**7.2.1.2** The welding procedures used shall produce weldments with the mechanical properties required by the design.

**7.2.1.3** Material specifications listed in Section 2 of this standard but not included in Table QW-422 of Section IX of the ASME Code shall be considered as P1 material with group numbers assigned as follows according to the minimum tensile strength specified:

- a. Less than or equal to 485 MPa (70 ksi)—Group 1.
- b. Greater than 485 MPa (70 ksi) but less than or equal to 550 MPa (80 ksi)—Group 2.
- c. Greater than 550 MPa (80 ksi)—Group 3.

Separate welding procedures and performance qualifications shall be conducted for A 841M/A 841 material.

**7.2.1.4** Welding variables (including supplementary essential variables when impact tests are required by 7.2.2), as defined by QW-250 of Section IX of the ASME Code, shall be used to determine the welding procedure specifications and the procedure qualification records to be instituted. In addition, when impact tests of the heat-affected zone are required, the heat-treated condition of the base material shall be a supplementary essential variable. If a protective coating

has been applied to weld edge preparations, the coating shall be included as an essential variable of the welding procedure specification, as required by 5.2.1.9.

#### 7.2.2 Impact Tests

**7.2.2.1** Impact tests for the qualification of welding procedures shall comply with the applicable provisions of 2.2.8 and shall be made at or below the design metal temperature.

**7.2.2.2** When impact testing of a material is required by 2.2.8 or 2.2.9, impact tests of the heat-affected zone shall be made for all automatic and semiautomatic procedures.

**7.2.2.3** For all materials to be used at a design metal temperature below 10°C (50°F), the qualification of the welding procedure for vertical joints shall include impact tests of the weld metal. If vertical joints are to be made by an automatic or semiautomatic process, impact tests of the heat-affected zone shall also be made.

**7.2.2.4** Impact tests of the weld metal shall be made for all procedures used for welding the components listed in 2.2.9.1 and attachments to these components when the design metal temperature is below -7°C (20°F).

**7.2.2.5** Impact tests shall show minimum values for acceptance in accordance with 2.2.8.3 and the following:

- a. For P1, Group 1, materials—20 J (15 ft-lbf), average of three specimens.
- b. For P1, Group 2, materials—27 J (20 ft-lbf), average of three specimens.
- c. For P1, Group 3, materials—34 J (25 ft-lbf), average of three specimens.

For shell plates thicker than 40 mm (1½ in.), these values shall be increased by 7 J (5 ft-lbf) for each 12.5 mm (½ in.) over 40 mm (1½ in.). Interpolation is permitted.

**7.2.2.6** Weld-metal impact specimens shall be taken across the weld with one face substantially parallel to and within 1.5 mm (1/16 in.) of the surface of the material. The notch shall be cut normal to the original material surface and with the weld metal entirely within the fracture zone.

**7.2.2.7** Heat-affected-zone impact specimens shall be taken across the weld and as near the surface of the material as is practicable. Each specimen shall be etched to locate the heat-affected zone, and the notch shall be cut approximately normal to the original material surface and with as much heat-affected-zone material as possible included in the fracture zone.

**7.2.2.8** Production welding shall conform to the qualified welding procedure, but production-weld test plates need not be made.

### **7.3 QUALIFICATION OF WELDERS**

**7.3.1** The erection manufacturer and the fabrication manufacturer, if other than the erection manufacturer, shall conduct tests for all welders assigned to manual and semiautomatic welding and all operators assigned to automatic welding to demonstrate the welders' and operators' ability to make acceptable welds. Tests conducted by one manufacturer shall not qualify a welder or welding operator to do work for another manufacturer.

**7.3.2** The welders and welding operators who weld pressure parts and join nonpressure parts, such as all permanent and temporary clips and lugs, to pressure parts shall be qualified in accordance with Section IX of the ASME Code.

**7.3.3** The records of the tests for qualifying welders and welding operators shall include the following:

a. Each welder or welding operator shall be assigned an identifying number, letter, or symbol by the fabrication or erection manufacturer.

b. The fabrication or erection manufacturer shall maintain a record of the welders or welding operators employed that shows the date and results of the tests for each welder or operator and the identifying mark assigned to each welder or operator. This record shall be certified by the fabrication or erection manufacturer and shall be accessible to the inspector.

### **7.4 IDENTIFICATION OF WELDED JOINTS**

The welder or welding operator's identification mark shall be hand- or machine-stamped adjacent to and at intervals not exceeding 1 m (3 ft) along the completed welds. In lieu of stamping, a record may be kept that identifies the welder or welding operator employed for each welded joint; these records shall be accessible to the inspector. Roof plate welds and flange-to-nozzle-neck welds do not require welder identification.

## SECTION 8—MARKING

### 8.1 NAMEPLATES

**8.1.1** A tank made in accordance with this standard shall be identified by a nameplate similar to that shown in Figure 8-1. The nameplate shall indicate, by means of letters and numerals not less than 4 mm (<sup>5</sup>/<sub>32</sub> in.) high, the following information:

- a. API Standard 650.
- b. The applicable appendix to API Standard 650.
- c. The year the tank was completed.
- 00 | d. The date of the edition and the addendum number of API Standard 650.
- e. The nominal diameter and nominal height, in meters (feet and inches) (unless other units are specified by the purchaser).
- 00 | ● f. The maximum capacity (see 3.2.5.2), in m<sup>3</sup> (42-gallon barrels) (unless other units are specified by the purchaser).
- 00 | ● g. The design liquid level (see 3.6.3.2), in meters (feet and inches) (unless other units are specified by the purchaser).
- h. The design specific gravity of the liquid.
- i. The design pressure, which shall be shown as atmospheric unless Appendix F applies.

- j. The design metal temperature as described in 2.2.9.3 in degrees Centigrade (Fahrenheit), unless other units are specified by the purchaser. | 00
- k. The maximum operating temperature, in degrees Celsius (Fahrenheit) (unless other units are specified by the purchaser), which shall not exceed 90°C (200°F) except in cases where Appendix M applies. | 00
- l. The name of the fabrication manufacturer if other than the erection manufacturer. The manufacturer's serial number or contract number shall be from the erection manufacturer. | 00
- m. The material specification number for each shell course. | 00
- n. When stress relief is applied to a part in accordance with the requirements of 3.7.4, the letters "SR." | 00
- o. The purchaser's tank number. | 00

**8.1.2** The nameplate shall be attached to the tank shell adjacent to a manhole or to a manhole reinforcing plate immediately above a manhole. A nameplate that is placed directly on the shell plate or reinforcing plate shall be attached by continuous welding or brazing all around the nameplate. A nameplate that is riveted or otherwise perma-

API STANDARD 650			
APPENDIX	<input type="text"/>	YEAR COMPLETED	<input type="text"/>
EDITION	<input type="text"/>	ADDENDUM NO.	<input type="text"/>
NOMINAL DIAMETER	<input type="text"/>	NOMINAL HEIGHT	<input type="text"/>
MAXIMUM CAPACITY	<input type="text"/>	DESIGN LIQUID LEVEL	<input type="text"/>
DESIGN SPECIFIC GRAVITY	<input type="text"/>	DESIGN METAL TEMP.	<input type="text"/>
DESIGN PRESSURE	<input type="text"/>	MAXIMUM OPERATING TEMP.	<input type="text"/>
MANUFACTURER'S SERIAL NO.	<input type="text"/>	PARTIAL STRESS RELIEF	<input type="text"/>
		PURCHASER'S TANK NO.	<input type="text"/>
FABRICATED BY	<input style="width: 100%;" type="text"/>		
ERECTED BY	<input style="width: 100%;" type="text"/>		
SHELL COURSE		MATERIAL	

- Note: At the purchaser's request or at the erection manufacturer's discretion, additional pertinent information may be shown on the nameplate, and the size of the nameplate may be increased proportionately.

Figure 8-1—Manufacturer's Nameplate

<b>MANUFACTURER'S CERTIFICATION FOR A TANK BUILT TO API STANDARD 650</b>	
To	_____
	(name and address of purchaser)
	_____
	_____
We hereby certify that the tank constructed for you at	_____
	(location)
	_____
and described as follows:	_____
	(serial or contract number, diameter, height, capacity, floating or fixed roof)
	_____
meets all applicable requirements of API Standard 650,	_____ Edition, _____ Revision, Appendix
_____ , dated _____ ,	including the requirements for design, materials, fabrication, and erection.
The tank is further described on the attached as-built data sheet dated	_____ .
	_____
	Manufacturer
	_____
	Authorized Representative
	_____
	Date

Figure 8-2—Manufacturer's Certification Letter

nently attached to an auxiliary plate of ferrous material shall be attached to the tank shell plate or reinforcing plate by continuous welding. The nameplate shall be of corrosion-resistant metal.

**8.1.3** When a tank is fabricated and erected by a single organization, that organization's name shall appear on the nameplate as both fabricator and erector.

**8.1.4** When a tank is fabricated by one organization and erected by another, the names of both organizations shall appear on the nameplate, or separate nameplates shall be applied by each.

## 8.2 DIVISION OF RESPONSIBILITY

Unless otherwise agreed upon, when a tank is fabricated by one manufacturer and erected by another, the erection manu-

facturer shall be considered as having the primary responsibility. The erection manufacturer shall make certain that the materials used in the fabrication of the components and in the construction of the tank are in accordance with all applicable requirements.

## 8.3 CERTIFICATION

The manufacturer shall certify to the purchaser, by a letter such as that shown in Figure 8-2, that the tank has been constructed in accordance with the applicable requirements of this standard. An as-built data sheet in accordance with Appendix L shall be attached to the certification letter.

Note: At the purchaser's request or at the erection manufacturer's discretion, additional pertinent information may be shown on the nameplate, and the size of the nameplate may be increased proportionately.

## APPENDIX A—OPTIONAL DESIGN BASIS FOR SMALL TANKS

### A.1 Scope

- **A.1.1** This appendix provides requirements for field-erected tanks of relatively small capacity in which the stressed components have a maximum nominal thickness of 12.5 mm ( $1/2$  in.), including any corrosion allowance specified by the purchaser. The stressed components include the shell and reinforcing plates, bottom and shell reinforcing plates for flush-type cleanout fittings and flush-type connections, and bottom plates that are welded to the shell, but the stressed components do not include other bottom plates, covers, and nozzle and manhole necks and their flanges.

- **A.1.2** This appendix is applicable only when specified by the purchaser and is limited to design metal temperatures above  $-30^{\circ}\text{C}$  ( $-20^{\circ}\text{F}$ ) [above  $-40^{\circ}\text{C}$  ( $-40^{\circ}\text{F}$ ) when killed, fine-grain material is used].

**A.1.3** This appendix is applicable to any of the Section 2 materials, although the single allowable stress does not provide any advantage to higher strength steels.

**A.1.4** This appendix states only the requirements that differ from the basic rules in this standard. When differing requirements are not stated, the basic rules must be followed; however, the overturning effect of a wind load should be considered.

**A.1.5** Typical sizes, capacities, and shell-plate thicknesses are listed in Tables A-1 through A-4 for a design in accordance with A.4 (joint efficiency = 0.85; specific gravity = 1.0; and corrosion allowance = 0).

### A.2 Materials

**A.2.1** Shell-plate materials shall not be more than 12.5 mm ( $1/2$  in.) thick, as stated in A.1.1.

**A.2.2** For stressed components, the Group-I and Group-II materials listed in Table 2-3 may be used above a design metal temperature of  $-30^{\circ}\text{C}$  ( $-20^{\circ}\text{F}$ ) but need not conform to the toughness requirements of 2.2.9, Figure 2-1, and 7.2.2. Group-III and Group-IIIA materials may be used above a design metal temperature of  $-40^{\circ}\text{C}$  ( $-40^{\circ}\text{F}$ ) and shall conform to impact requirements of 7.2.2.

**A.2.3** Material used for shell nozzle and manhole necks and flanges shall conform to 2.5, 2.6, and Table 2-3 but need not conform to the toughness requirements of 2.2.9, 2.5.5, and Figure 2-1.

### A.3 Design

**A.3.1** The maximum tensile stress before the joint efficiency factor is applied shall be 145 MPa (21,000 lbf/in.<sup>2</sup>).

**A.3.2** Stresses shall be computed on the assumption that the tank is filled with water (specific gravity = 1.0) or with the liquid to be stored if it is heavier than water.

**A.3.3** The tension in each ring shall be computed 300 mm (12 in.) above the centerline of the lower horizontal joint of the course in question. When these stresses are computed, the tank diameter shall be taken as the nominal diameter of the bottom course.

- **A.3.4** The joint efficiency factor shall be 0.85 with the spot radiography required by A.5.3. By agreement between the purchaser and the manufacturer, the spot radiography may be omitted, and a joint efficiency factor of 0.70 shall be used.

### A.4 Thickness of Shell Plates

**A.4.1** The minimum thicknesses of shell plates shall be computed from the stress on the vertical joints, using the following formula:

In SI units:

$$t = \frac{4.9D(H - 0.3)G}{(E)(145)} + CA$$

where

- $t$  = minimum thickness, in mm (see 3.6.1.1),
- $D$  = nominal diameter of the tank, in m (see 3.6.1.1, Note 1),
- $H$  = design liquid level, in m (see 3.6.3.2),
- $G$  = specific gravity of the liquid to be stored, as specified by the purchaser. The specific gravity shall not be less than 1.0,
- $E$  = joint efficiency, which is either 0.85 or 0.70 (see A.3.4),

- $CA$  = corrosion allowance, in mm, as specified by the purchaser (see 3.3.2).

In US Customary units:

$$t = \frac{2.6D(H - 1)G}{(E)(21,000)} + CA$$

where

- $t$  = minimum thickness (in.) (see 3.6.1.1),
- $D$  = nominal diameter of the tank (ft) (see 3.6.1.1, Note 1),
- $H$  = design liquid level (ft) (see 3.6.3.2),
- $G$  = specific gravity of the liquid to be stored, as specified by the purchaser. The specific gravity shall not be less than 1.0,
- $E$  = joint efficiency, which is either 0.85 or 0.70 (see A.3.4),

- $CA$  = corrosion allowance (in.), as specified by the purchaser (see 3.3.2).

Table A-1a—Typical Sizes and Corresponding Nominal Capacities (m<sup>3</sup>)  
for Tanks with 1800 mm Courses

Column 1	Column 2	Column 3	Column 4	Column 5	Column 6	Column 7	Column 8	Column 9	Column 10	Column 11
Tank Diameter m	Capacity per m of Height m <sup>3</sup>	Tank Height (m) / Number of Courses in Completed Tank								
		3.6 / 2	5.4 / 3	7.2 / 4	9 / 5	10.8 / 6	12.6 / 7	14.4 / 8	16.2 / 9	18 / 10
3	7.07	25	38	51	64	76	—	—	—	—
4.5	15.9	57	86	115	143	172	—	—	—	—
6	28.3	102	153	204	254	305	356	407	—	—
7.5	44.2	159	239	318	398	477	557	636	716	795
9	63.6	229	344	458	573	687	802	916	1,031	1,145
10.5	86.6	312	468	623	779	935	1,091	1,247	1,403	1,559
12	113	407	611	814	1,018	1,221	1,425	1,629	1,832	2,036
13.5	143	515	773	1,031	1,288	1,546	1,804	2,061	2,319	2,576
15	177	636	954	1,272	1,590	1,909	2,227	2,545	2,863	3,181
18	254	916	1,374	1,832	2,290	2,748	3,206	3,664	4,122	4,580
										<i>D = 18</i>
21	346	1,247	1,870	2,494	3,117	3,741	4,364	4,988	5,089	—
24	452	1,629	2,443	3,257	4,072	4,886	5,700	5,474	<i>D = 20</i>	—
27	573	2,061	3,092	4,122	5,153	6,184	6,690	<i>D = 22</i>	—	—
30	707	2,545	3,817	5,089	6,362	7,634	<i>D = 26</i>	—	—	—
36	1,018	3,664	5,497	7,329	9,161	<i>D = 30</i>	—	—	—	—
					<i>D = 36</i>					
42	1,385	4,988	7,481	9,975	—	—	—	—	—	—
48	1,810	6,514	9,772	11,966	—	—	—	—	—	—
54	2,290	8,245	12,367	<i>D = 46</i>	—	—	—	—	—	—
60	2,827	10,179	15,268	—	—	—	—	—	—	—
66	3,421	12,316	16,303	—	—	—	—	—	—	—
			<i>D = 62</i>							

Note: The nominal capacities given in this table were calculated using the following formula:

In SI units:

$$C = 0.785D^2H$$

where

- C* = capacity of tank, in m<sup>3</sup>,  
*D* = diameter of tank, in m (see A.4.1),  
*H* = height of tank, in m (see A.4.1).

The capacities and diameters in italics (Columns 4–11) are the maximums for the tank heights given in the column heads, based on a maximum permissible shell-plate thickness of 12.5 mm, a maximum allowable design stress of 145 MPa, a joint efficiency of 0.85, and no corrosion allowance (see A.4.1).

Table A-1b—Typical Sizes and Corresponding Nominal Capacities (barrels)  
for Tanks with 72-in. Courses

Column 1	Column 2	Column 3	Column 4	Column 5	Column 6	Column 7	Column 8	Column 9	Column 10	Column 11
Tank Diameter ft	Capacity per ft of Height barrels	Tank Height (ft) / Number of Courses in Completed Tank								
		12 / 2	18 / 3	24 / 4	30 / 5	36 / 6	42 / 7	48 / 8	54 / 9	60 / 10
10	14.0	170	250	335	420	505	—	—	—	—
15	31.5	380	565	755	945	1,130	—	—	—	—
20	56.0	670	1,010	1,340	1,680	2,010	2,350	2,690	—	—
25	87.4	1,050	1,570	2,100	2,620	3,150	3,670	4,200	4,720	5,250
30	126	1,510	2,270	3,020	3,780	4,530	5,290	6,040	6,800	7,550
35	171	2,060	3,080	4,110	5,140	6,170	7,200	8,230	9,250	10,280
40	224	2,690	4,030	5,370	6,710	8,060	9,400	10,740	12,100	13,430
45	283	3,400	5,100	6,800	8,500	10,200	11,900	13,600	15,300	17,000
50	350	4,200	6,300	8,400	10,500	12,600	14,700	16,800	18,900	21,000
60	504	6,040	9,060	12,100	15,110	18,130	21,150	24,190	37,220	28,260
										<i>D = 58</i>
70	685	8,230	12,340	16,450	20,580	24,700	28,800	32,930	30,970	—
80	895	10,740	16,120	21,500	26,880	32,260	37,600	35,810	<i>D = 64</i>	—
90	1,133	13,600	20,400	27,220	34,030	40,820	40,510	<i>D = 73</i>	—	—
100	1,399	16,800	25,200	33,600	42,000	48,400	<i>D = 83</i>	—	—	—
120	2,014	24,190	36,290	48,380	58,480	<i>D = 98</i>	—	—	—	—
					<i>D = 118</i>					
140	2,742	32,930	49,350	65,860	—	—	—	—	—	—
160	3,581	43,000	64,510	74,600	—	—	—	—	—	—
180	4,532	54,430	81,650	<i>D = 149</i>	—	—	—	—	—	—
200	5,595	67,200	100,800	—	—	—	—	—	—	—
220	6,770	81,310	102,830	—	—	—	—	—	—	—
			<i>D = 202</i>							

Note: The nominal capacities given in this table were calculated using the following formula:

In US Customary units:

$$C = 0.14D^2H,$$

where

$C$  = capacity of tank, in 42-gal barrels,  
 $D$  = diameter of tank, in ft (see A.4.1),  
 $H$  = height of tank, in ft (see A.4.1).

The capacities and diameters in italics (Columns 4–11) are the maximums for the tank heights given in the column heads, based on a maximum permissible shell-plate thickness of  $1/2$  in., a maximum allowable design stress of 21,000 psi, a joint efficiency of 0.85, and no corrosion allowance (see A.4.1).

Table A-2a—Shell-Plate Thicknesses (mm) for Typical Sizes of Tanks with 1800 mm Courses

Column 1	Column 2	Column 3	Column 4	Column 5	Column 6	Column 7	Column 8	Column 9	Column 10	Column 11	Column 12
Tank Diameter m	Tank Height (m) / Number of Courses in Completed Tank										Maximum Allowable Height for Diameter <sup>a</sup> m
	1.8 / 1	3.6 / 2	5.4 / 3	7.2 / 4	9 / 5	10.8 / 6	12.6 / 7	14.4 / 8	16.2 / 9	18 / 10	
3	5.0	5.0	5.0	5.0	5.0	5.0	—	—	—	—	—
4.5	5.0	5.0	5.0	5.0	5.0	5.0	—	—	—	—	—
6	5.0	5.0	5.0	5.0	5.0	5.0	5.0	5.0	—	—	—
7.5	5.0	5.0	5.0	5.0	5.0	5.0	5.0	5.0	5.0	5.3	—
9	5.0	5.0	5.0	5.0	5.0	5.0	5.0	5.0	5.7	6.3	—
10.5	5.0	5.0	5.0	5.0	5.0	5.0	5.1	5.9	6.6	7.4	—
12	5.0	5.0	5.0	5.0	5.0	5.0	5.9	6.7	7.6	8.4	—
13.5	5.0	5.0	5.0	5.0	5.0	5.6	6.6	7.6	8.5	9.5	—
15	6.0	6.0	6.0	6.0	6.0	6.3	7.3	8.4	9.5	10.6	—
18	6.0	6.0	6.0	6.0	6.2	7.5	8.8	10.1	11.4	—	17.8
21	6.0	6.0	6.0	6.0	7.3	8.8	10.3	11.8	—	—	15.3
24	6.0	6.0	6.0	6.6	8.3	10.0	11.7	—	—	—	13.4
27	6.0	6.0	6.0	7.4	9.3	11.3	—	—	—	—	11.9
30	6.0	6.0	6.0	8.2	10.4	12.5	—	—	—	—	10.8
36	8.0	8.0	8.0	9.9	12.5	—	—	—	—	—	9.0
42	8.0	8.0	8.5	11.5	—	—	—	—	—	—	7.8
48	8.0	8.0	9.7	—	—	—	—	—	—	—	6.9
54	8.0	8.0	10.9	—	—	—	—	—	—	—	6.1
60	8.0	8.0	12.2	—	—	—	—	—	—	—	5.5
66	10.0	10.0	—	—	—	—	—	—	—	—	5.1

<sup>a</sup>Based on a maximum permissible shell-plate thickness of 12.5 mm, a maximum allowable design stress of 145 MPa, a joint efficiency of 0.85, and no corrosion allowance.

Note: The plate thicknesses shown in this table are based on a maximum allowable design stress of 145 MPa, a joint efficiency of 0.85, and no corrosion allowance (see A.4.1).

Table A-2b—Shell-Plate Thicknesses (in.) for Typical Sizes of Tanks with 72-in. Courses

Column 1	Column 2	Column 3	Column 4	Column 5	Column 6	Column 7	Column 8	Column 9	Column 10	Column 11	Column 12
Tank Diameter ft	Tank Height (ft) / Number of Courses in Completed Tank										Maximum Allowable Height for Diameter <sup>a</sup> ft
	6 / 1	12 / 2	18 / 3	24 / 4	30 / 5	36 / 6	42 / 7	48 / 8	54 / 9	60 / 10	
10	3/16	3/16	3/16	3/16	3/16	3/16	—	—	—	—	—
15	3/16	3/16	3/16	3/16	3/16	3/16	—	—	—	—	—
20	3/16	3/16	3/16	3/16	3/16	3/16	3/16	3/16	—	—	—
25	3/16	3/16	3/16	3/16	3/16	3/16	3/16	3/16	0.20	0.22	—
30	3/16	3/16	3/16	3/16	3/16	3/16	3/16	0.21	0.24	0.26	—
35	3/16	3/16	3/16	3/16	3/16	3/16	0.21	0.24	0.27	0.30	—
40	3/16	3/16	3/16	3/16	3/16	0.21	0.24	0.28	0.31	0.35	—
45	3/16	3/16	3/16	3/16	3/16	0.23	0.27	0.31	0.35	0.38	—
50	1/4	1/4	1/4	1/4	1/4	0.26	0.30	0.35	0.39	0.43	—
60	1/4	1/4	1/4	1/4	0.26	0.31	0.36	0.41	0.47	—	58.2
70	1/4	1/4	1/4	1/4	0.30	0.36	0.42	0.48	—	—	50.0
80	1/4	1/4	1/4	0.27	0.34	0.41	0.48	—	—	—	43.9
90	1/4	1/4	1/4	0.31	0.38	0.46	—	—	—	—	39.1
100	1/4	1/4	1/4	0.34	0.43	—	—	—	—	—	35.3
120	5/16	5/16	5/16	0.41	—	—	—	—	—	—	29.6
140	5/16	5/16	0.35	0.47	—	—	—	—	—	—	25.5
160	5/16	5/16	0.40	—	—	—	—	—	—	—	22.5
180	5/16	5/16	0.45	—	—	—	—	—	—	—	20.1
200	5/16	0.32	0.50	—	—	—	—	—	—	—	18.2
220	3/8	3/8	—	—	—	—	—	—	—	—	16.6

<sup>a</sup>Based on a maximum permissible shell-plate thickness of 1/2 in., a maximum allowable design stress of 21,000 psi, a joint efficiency of 0.85, and no corrosion allowance.

Note: The plate thicknesses shown in this table are based on a maximum allowable design stress of 21,000 psi, a joint efficiency of 0.85, and no corrosion allowance (see A.4.1).

Table A-3a—Typical Sizes and Corresponding Nominal Capacities (m<sup>3</sup>)  
for Tanks with 2400 mm Courses

Column 1	Column 2	Column 3	Column 4	Column 5	Column 6	Column 7	Column 8	Column 9
Tank Diameter m	Capacity per m of Height m <sup>3</sup>	Tank Height (m) / Number of Courses in Completed Tank						
		4.8 / 2	7.2 / 3	9.6 / 4	12 / 5	14.4 / 6	16.8 / 7	19.2 / 8
3	7.07	34	51	68	—	—	—	—
4.5	15.9	76	115	153	191	—	—	—
6	28.3	136	204	272	339	407	—	—
7.5	44.2	212	318	424	530	636	742	848
9	63.6	305	458	610	763	916	1,069	1,221
10.5	86.6	416	623	831	1,039	1,247	1,455	1,663
12	113	543	814	1085	1,357	1,629	1,900	2,171
13.5	143	687	1,031	1373	1,718	2,061	2,405	2,748
15	177	848	1,272	1696	2,121	2,545	2,969	3,393
18	254	1,221	1,832	2442	3,054	3,664	4,275	4,358
								<i>D = 17</i>
21	346	1,663	2,494	3323	4,156	4,988	4,763	—
24	452	2,171	3,257	4341	5,429	5,474	<i>D = 19</i>	—
27	573	2,748	4,122	5494	6,871	<i>D = 22</i>	—	—
30	707	3,393	5,089	6782	<i>D = 27</i>	—	—	—
36	1,018	4,886	7,329	8712	—	—	—	—
				<i>D = 34</i>				
42	1,385	6,650	9,975	—	—	—	—	—
48	1,810	8,686	11,966	—	—	—	—	—
54	2,290	10,993	<i>D = 46</i>	—	—	—	—	—
60	2,827	13,572	—	—	—	—	—	—
66	3,421	16,422	—	—	—	—	—	—

Note: The nominal capacities given in this table were calculated using the following formula:

In SI units:

$$C = 0.785D^2H$$

where

$C$  = capacity of tank, in m<sup>3</sup>,  
 $D$  = diameter of tank, in m (see A.4.1),  
 $H$  = height of tank, in m (see A.4.1).

The capacities and diameters in italics (Columns 4–9) are the maximums for the tank heights given in the column heads, based on a maximum permissible shell-plate thickness of 12.5 mm, a maximum allowable design stress of 145 MPa, a joint efficiency of 0.85, and no corrosion allowance (see A.4.1).

Table A-3b—Typical Sizes and Corresponding Nominal Capacities (barrels)  
for Tanks With 96-in. Courses

Column 1	Column 2	Column 3	Column 4	Column 5	Column 6	Column 7	Column 8	Column 9
Tank Diameter ft	Capacity per ft of Height barrels	Tank Height (ft) / Number of Courses in Completed Tank						
		16 / 2	24 / 3	32 / 4	40 / 5	48 / 6	56 / 7	64 / 8
10	14.0	225	335	450	—	—	—	—
15	31.5	505	755	1,010	1,260	—	—	—
20	56.0	900	1,340	1,790	2,240	2,690	—	—
25	87.4	1,400	2,100	2,800	3,500	4,200	4,900	5,600
30	126	2,020	3,020	4,030	5,040	6,040	7,050	8,060
35	171	2,740	4,110	5,480	6,850	8,230	9,600	10,980
40	224	3,580	5,370	7,160	8,950	10,740	12,540	14,340
45	283	4,530	6,800	9,060	11,340	13,600	15,880	18,140
50	350	5,600	8,400	11,200	14,000	16,800	19,600	22,400
60	504	8,060	12,100	16,130	20,160	24,190	28,220	26,130
								<i>D = 54</i>
70	685	10,960	16,450	21,950	27,440	32,930	<i>30,140</i>	—
80	895	14,320	21,500	28,670	35,840	<i>35,810</i>	<i>D = 62</i>	—
90	1,133	18,130	27,220	36,290	<i>45,360</i>	<i>D = 73</i>	—	—
100	1,399	22,380	33,600	44,800	<i>D = 88</i>	—	—	—
120	2,014	32,250	48,380	<i>54,200</i>	—	—	—	—
				<i>D = 110</i>				
140	2,742	43,900	65,860	—	—	—	—	—
160	3,581	57,340	<i>74,600</i>	—	—	—	—	—
180	4,532	72,570	<i>D = 149</i>	—	—	—	—	—
200	5,595	89,600	—	—	—	—	—	—
220	6,770	108,410	—	—	—	—	—	—

Note: The nominal capacities given in this table were calculated using the following formula:

In US Customary units:

$$C = 0.14D^2H,$$

where

$C$  = capacity of tank, in 42-gal barrels,  
 $D$  = diameter of tank, in ft (see A.4.1),  
 $H$  = height of tank, in ft (see A.4.1).

The capacities and diameters in italics (Columns 4–9) are the maximums for the tank heights given in the column heads, based on a maximum permissible shell-plate thickness of  $1/2$  in., a maximum allowable design stress of 21,000 psi, a joint efficiency of 0.85, and no corrosion allowance (see A.4.1).

Table A-4a—Shell-Plate Thicknesses (mm) for Typical Sizes of Tanks  
with 2400 mm Courses

Column 1	Column 2	Column 3	Column 4	Column 5	Column 6	Column 7	Column 8	Column 9	Column 10
Tank Height Diameter m	Tank Height (m) / Number of Courses in Completed Tank								Maximum Allowable Height for Diameter <sup>a</sup> m
	2.4 / 1	4.8 / 2	7.2 / 3	9.6 / 4	12 / 5	14.4 / 6	16.8 / 7	19.2 / 8	
3	5.0	5.0	5.0	5.0	—	—	—	—	—
4.5	5.0	5.0	5.0	5.0	5.0	—	—	—	—
6	5.0	5.0	5.0	5.0	5.0	5.0	—	—	—
7.5	5.0	5.0	5.0	5.0	5.0	5.0	5.0	5.0	—
9	5.0	5.0	5.0	5.0	5.0	5.0	5.0	5.0	—
10.5	5.0	5.0	5.0	5.0	5.0	5.0	5.1	5.9	—
12	5.0	5.0	5.0	5.0	5.0	5.0	5.9	6.7	—
13.5	5.0	5.0	5.0	5.0	5.0	5.6	6.6	7.6	—
15	6.0	6.0	6.0	6.0	6.0	6.3	7.3	8.4	—
18	6.0	6.0	6.0	6.0	6.2	7.5	8.8	10.1	17.8
21	6.0	6.0	6.0	6.0	7.3	8.8	10.3	11.8	15.3
24	6.0	6.0	6.0	6.6	8.3	10.0	11.7	—	13.4
27	6.0	6.0	6.0	7.4	9.3	11.3	—	—	11.9
30	6.0	6.0	6.1	8.2	10.4	12.5	—	—	10.8
36	8.0	8.0	8.0	9.9	12.5	—	—	—	9.0
42	8.0	8.0	8.5	11.5	—	—	—	—	7.8
48	8.0	8.0	9.7	—	—	—	—	—	6.9
54	8.0	8.0	10.9	—	—	—	—	—	6.1
60	8.0	8.0	12.2	—	—	—	—	—	5.5
66	10.0	10.0	—	—	—	—	—	—	5.1

<sup>a</sup>Based on a maximum permissible shell-plate thickness of 12.5 mm, a maximum allowable design stress of 145 MPa, a joint efficiency of 0.85, and no corrosion allowance.

Note: The plate thicknesses shown in this table are based on a maximum allowable design stress of 145 MPa, a joint efficiency of 0.85, and no corrosion allowance (see A.4.1).

Table A-4b—Shell-Plate Thicknesses (in.) for Typical Sizes of Tanks with 96-in. Courses

Column 1	Column 2	Column 3	Column 4	Column 5	Column 6	Column 7	Column 8	Column 9	Column 10
Tank Height Diameter ft	Tank Height (ft) / Number of Courses in Completed Tank								Maximum Allowable Height for Diameter <sup>a</sup> ft
	8 / 1	16 / 2	24 / 3	32 / 4	40 / 5	48 / 6	56 / 7	64 / 8	
10	3/16	3/16	3/16	3/16	—	—	—	—	—
15	3/16	3/16	3/16	3/16	3/16	—	—	—	—
20	3/16	3/16	3/16	3/16	3/16	3/16	—	—	—
25	3/16	3/16	3/16	3/16	3/16	3/16	0.20	0.23	—
30	3/16	3/16	3/16	3/16	3/16	0.21	0.24	0.28	—
35	3/16	3/16	3/16	3/16	0.20	0.24	0.28	0.33	—
40	3/16	3/16	3/16	3/16	0.23	0.28	0.32	0.37	—
45	3/16	3/16	3/16	0.21	0.26	0.31	0.36	0.42	—
50	1/4	1/4	1/4	0.25	0.29	0.35	0.40	0.46	—
60	1/4	1/4	1/4	0.27	0.34	0.41	0.48	—	58.2
70	1/4	1/4	1/4	0.32	0.40	0.48	—	—	50.0
80	1/4	1/4	0.27	0.37	0.46	—	—	—	43.9
90	1/4	1/4	0.31	0.41	—	—	—	—	39.1
100	1/4	1/4	0.34	0.46	—	—	—	—	35.3
120	5/16	5/16	0.41	—	—	—	—	—	29.6
140	5/16	5/16	0.47	—	—	—	—	—	25.5
160	5/16	0.35	—	—	—	—	—	—	22.5
180	5/16	0.40	—	—	—	—	—	—	20.1
200	5/16	0.44	—	—	—	—	—	—	18.2
220	3/8	0.48	—	—	—	—	—	—	16.6

<sup>a</sup>Based on a maximum permissible shell-plate thickness of 1/2 in., a maximum allowable design stress of 21,000 psi, a joint efficiency of 0.85, and no corrosion allowance.

Note: The plate thicknesses shown in this table are based on a maximum allowable design stress of 21,000 psi, a joint efficiency of 0.85, and no corrosion allowance (see A.4.1).

**A.4.2** The nominal thickness of shell plates (including shell extensions for floating roofs) shall not be less than that listed in 3.6.1.1. The nominal thickness of shell plates refers to the tank shell as constructed. The nominal thicknesses given in 3.6.1.1 are based on erection requirements.

## A.5 Tank Joints

**A.5.1** Vertical and horizontal joints in the shell, bottom joints, shell-to-bottom joints, wind-girder joints, and roof and top-angle joints shall conform to 3.1.5.

**A.5.2** The requirements of 3.7.3 for the spacing of welds do not apply except for the requirement that the spacing between the toes of welds around a connection shall not be less than  $2\frac{1}{2}$  times the shell thickness at the connection.

**A.5.3** When radiographic inspection is required (joint efficiency = 0.85), the spot radiographs of vertical joints shall conform to 6.1.2.2, Item a, excluding the 10 mm ( $\frac{3}{8}$ -in.) shell-thickness limitation in Item a and excluding the additional random spot radiograph required by Item a. The spot radiographs of horizontal joints shall conform to 6.1.2.3.

## ● A.6 Intermediate Wind Girders

Calculations for and installation of intermediate wind girders are not required unless specified by the purchaser.

## A.7 Shell Manholes and Nozzles

**A.7.1** Except for other designs and shapes permitted by 3.7.1.2, shell manholes shall conform to 3.7.5, Figures 3-4A and 3-4B, and Tables 3-3 through 3-7.

**A.7.2** Shell nozzles and flanges shall conform to 3.7.6; Figures 3-4B, 3-5, and 3-7; and Tables 3-8 through 3-10.

**A.7.3** The radiographic requirements of 3.7.3.4 do not apply.

## A.8 Flush-Type Cleanout Fittings

**A.8.1** The details and dimensions of flush-type cleanout fittings shall conform to 3.7.7, Figures 3-9 and 3-10, and Tables 3-11 through 3-13.

● **A.8.2** The provisions for stress relief specified in 3.7.4 and 3.7.7.3 are not required unless they are specified by the purchaser or unless any plate in the unit has a thickness greater than 16 mm ( $\frac{5}{8}$  in.).

## A.9 Flush-Type Shell Connections

The details and dimensions of flush-type shell connections shall conform to 3.7.8, Figure 3-11, and Table 3-14.

## A.10 Flush-Type Bolted Door Sheets

**A.10.1** Flush-type bolted door sheets shall conform to Figure A-1 and Table A-5.

**A.10.2** Bolted door sheets shall be based on the specific design requirements in A.10.2.1 through A.10.2.7.

**A.10.2.1** The minimum net cross-sectional area of the door plate, excluding the tapered ends, shall not be less than the product of the shell-plate thickness and the vertical height of the cutout in the shell plus twice the diameter of the bolt hole:

$$t_D (h_D - N_1 d) = t_s (h_c + 2d)$$

where

$t_D$  = thickness of the door plate, in mm (in.),

$h_D$  = height of the door plate, mm (in.),

$N_1$  = number of bolts in the first row of bolts next to the shell cutout,

$d$  = diameter of bolts and bolt holes, in mm (in.),

$t_s$  = thickness of the shell plate, in mm (in.),

$h_c$  = height of the shell cutout, in mm (in.).

**A.10.2.2** The shear stress in the cross-section of the bolts shall not exceed 110 MPa (16,000 lbf/in.<sup>2</sup>).

**A.10.2.3** The bearing stress on the bolts and bolt holes shall not exceed 220 MPa (32,000 lbf/in.<sup>2</sup>), and the fit of the turned bolt in the reamed hole shall conform to the standards of AISC.

**A.10.2.4** The shear strength of the bolted door sheet connection shall be at least 90% of the design tensile strength of the undisturbed shell plate as illustrated in the equations below. For shear loading on a flush-type door sheet:

In SI units:

$$(N)(a)(110) = t_s(h_c + 2.5d + f)(145)(0.9)$$

For shear loading on a raised-type door sheet:

$$(N)(a)(110) = t_s(h_c + 4d)(145)(0.9)$$

where

$N$  = number of bolts required in each end section of door plate,

$a$  = cross-sectional area of the bolts, in mm<sup>2</sup>,

$f$  = distance from the bottom of the shell cutout to the centerline of the bottom row of bolts, in mm.

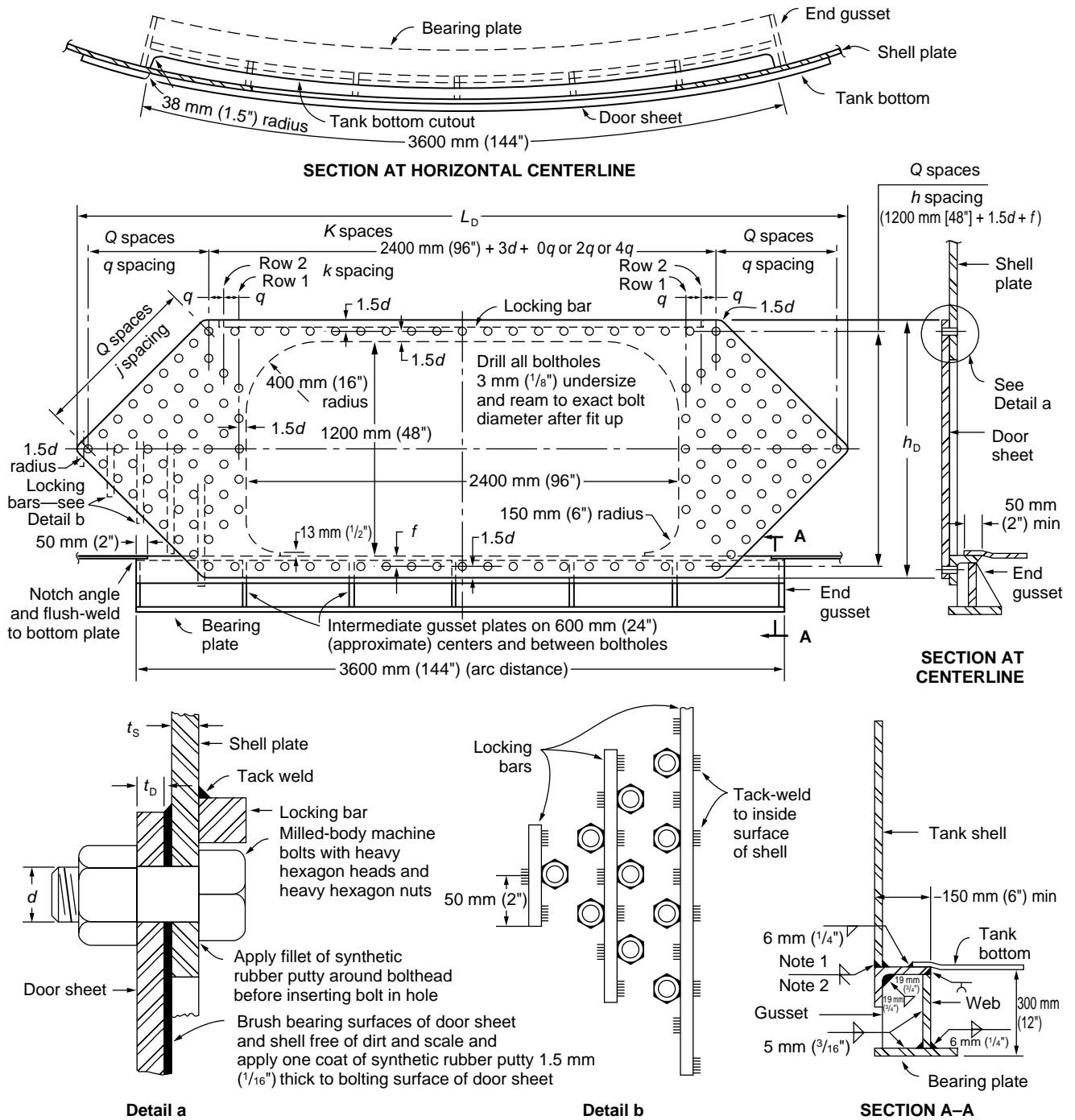
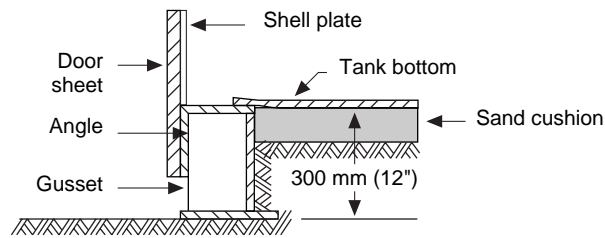

Figure A-1—Flush-Type Bolted Door Sheet (See Table A-5)

Table A-5—Flush-Type Bolted Door Sheets (See Figure A-1)

(All dimensions in mm)					(All dimensions in inches)				
Column 1	Column 2	Column 3	Column 4	Column 5	Column 1	Column 2	Column 3	Column 4	Column 5
Shell Thickness $t_s$	$Q$	$q$	$h$	$j$	Shell Thickness $t_s$	$Q$	$q$	$h$	$j$
6	7	51	185.0	105.6	$1/4$	7	$1^{5/16}$	7.375	4.165
8	8	51	161.9	95.7	$5/16$	8	$1^{5/16}$	6.453	3.766
10	8	51	161.9	95.7	$3/8$	8	$1^{5/16}$	6.453	3.766
11	8	62	162.6	102.3	$7/16$	8	$2^{1/4}$	6.477	3.945
13	8	62	162.6	102.3	$1/2$	8	$2^{1/4}$	6.477	3.945
Column 6	Column 7	Column 8	Column 9	Column 10	Column 6	Column 7	Column 8	Column 9	Column 10
$K$	$k$	$t_D$	$h_D$	$f$	$K$	$k$	$t_D$	$h_D$	$f$
36	71.2	11	1355	65	36	2.837	$7/16$	$53^{7/8}$	$2^{1/2}$
30	82.0	11	1355	65	30	3.275	$7/16$	$53^{7/8}$	$2^{1/2}$
30	88.8	11	1355	65	30	3.533	$7/16$	$53^{7/8}$	$2^{1/2}$
24	107.9	13	1364	65	24	4.297	$1/2$	$54^{7/16}$	$2^{1/2}$
22	123.4	14	1364	65	22	4.892	$9/16$	$54^{7/16}$	$2^{1/2}$
Column 11	Column 12	Column 13	Column 14	Column 15	Column 11	Column 12	Column 13	Column 14	Column 15
$L_D$	Number of Bolts			Bolt Diameter $d$	$L_D$	Number of Bolts			Bolt Diameter $d$
	Row 1	Row 2	Total			Row 1	Row 2	Total	
3336	0	7	156	20	$131^{1/2}$	—	7	156	$3/4$
3336	0	0	146	20	$131^{1/2}$	—	—	146	$3/4$
3540	3	6	164	20	$139^{1/4}$	3	6	164	$3/4$
3648	0	2	138	22	$141^{3/4}$	—	2	138	$7/8$
3772	3	6	148	22	$146^{1/4}$	3	6	148	$7/8$
Column 16	Column 17	Column 18	Column 19	Column 20	Column 16	Column 17	Column 18	Column 19	Column 20
Bolt Length	Length of Bolt Thread	Square Locking Bar	Angle	Web	Bolt Length	Length of Bolt Thread	Square Locking Bar	Angle	Web
50	35	16	$152 \times 102 \times 9.5$	$6 \times 290$	2	$1^{1/8}$	$5/8$	$6 \times 4 \times 3/8$	$1/4 \times 11^{5/8}$
50	35	16	$152 \times 102 \times 9.5$	$6 \times 290$	2	$1^{1/16}$	$5/8$	$6 \times 4 \times 3/8$	$1/4 \times 11^{5/8}$
50	35	16	$152 \times 102 \times 9.5$	$6 \times 290$	2	1	$5/8$	$6 \times 4 \times 3/8$	$1/4 \times 11^{5/8}$
55	35	20	$152 \times 102 \times 12.7$	$10 \times 285$	$2^{1/4}$	$1^{1/8}$	$3/4$	$6 \times 4 \times 1/2$	$3/8 \times 11^{3/8}$
65	40	20	$152 \times 102 \times 12.7$	$10 \times 285$	$2^{1/2}$	$1^{1/4}$	$3/4$	$6 \times 4 \times 1/2$	$3/8 \times 11^{3/8}$
Column 21	Column 22	Column 23	Column 21	Column 22	Column 23				
Intermediate Gusset	End Gusset	Bearing Plate	Intermediate Gusset	End Gusset	Bearing Plate				
$6 \times 125 \times 290$	$6 \times 200 \times 290$	$6 \times 225$	$1/4 \times 5 \times 11^{5/8}$	$1/4 \times 8 \times 11^{5/8}$	$1/4 \times 9$				
$6 \times 125 \times 290$	$6 \times 200 \times 290$	$6 \times 225$	$1/4 \times 5 \times 11^{5/8}$	$1/4 \times 8 \times 11^{5/8}$	$1/4 \times 9$				
$6 \times 125 \times 290$	$6 \times 200 \times 290$	$6 \times 225$	$1/4 \times 5 \times 11^{5/8}$	$1/4 \times 8 \times 11^{5/8}$	$1/4 \times 9$				
$10 \times 125 \times 285$	$10 \times 200 \times 285$	$10 \times 225$	$3/8 \times 5 \times 11^{3/8}$	$3/8 \times 8 \times 11^{3/8}$	$3/8 \times 9$				
$10 \times 125 \times 285$	$10 \times 200 \times 285$	$10 \times 225$	$3/8 \times 5 \times 11^{3/8}$	$3/8 \times 8 \times 11^{3/8}$	$3/8 \times 9$				

Note: Washers shall be used on both sides of the plate for shell thicknesses of 16 mm ( $5/8$  in.) or less.



**METHOD A—TANK RESTING ON EARTH GRADE, WITH OR WITHOUT RETAINING WALL**

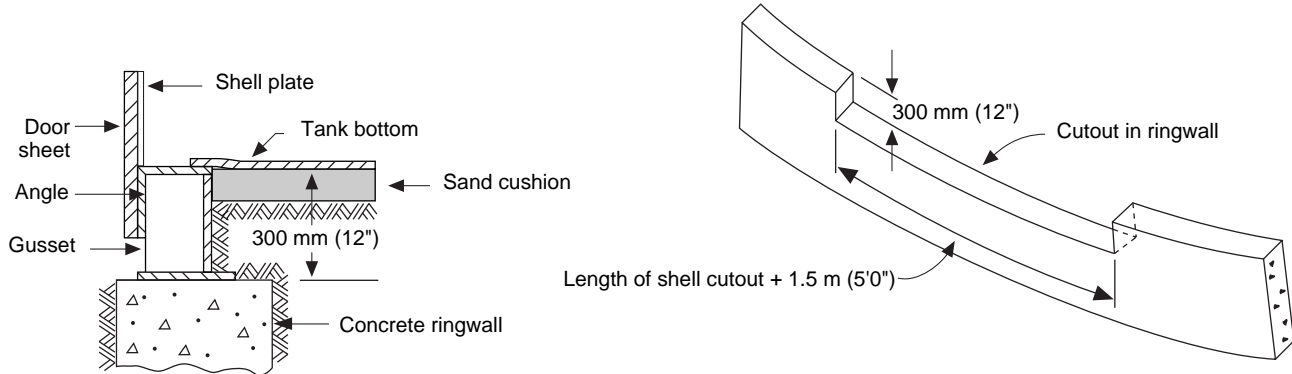

**METHOD B—TANK RESTING ON CONCRETE RINGWALL**

Note: Before the bottom plate is attached to the angle, (a) a sand cushion shall be placed flush with the top of the angle, and (b) the earth fill and sand cushion shall be thoroughly compacted.

Figure A-2—Supports for Flush-Type Bolted Door Sheet

In US Customary units:

$$(N)(a)(16,000) = t_s(h_c + 2.5d + f)(21,000)(0.90)$$

For shear loading on a raised-type door sheet:

$$(N)(a)(16,000) = t_s(h_c + 4d)(21,000)(0.90)$$

where

$N$  = number of bolts required in each end section of door plate,

$a$  = cross-sectional area of the bolts (in.<sup>2</sup>),

$f$  = distance from the bottom of the shell cutout to the centerline of the bottom row of bolts (in.).

**A.10.2.5** The distance between centers of bolt holes shall not be less than three times the bolt diameter, and the spacing of bolt holes at the sealing edge of the plate shall not exceed seven times the sum of the minimum door-sheet thickness plus the nominal bolt diameter plus the washer thickness (if washers are used).

**A.10.2.6** The tensile stress in the net section of the door plate at the first row of bolt holes next to the shell-plate cutout

shall not exceed 145 MPa (21,000 lbf/in.<sup>2</sup>), and at the subsequent rows, the tensile stress shall not exceed 145 MPa (21,000 lbf/in.<sup>2</sup>), after allowance is made for the total shearing value or bearing value (whichever is less) of the bolts in the preceding row or rows.

**A.10.2.7** The following provisions apply to flush-type bolted door sheets:

- The girder shall be designed to withstand the bending moment that would result if the ends of the girder were on hard ground and the center was unsupported.
- The load on the girder shall be equal to the weight of a column of water with the following dimensions: 1) 0.03 times the tank radius, in m (ft); 2) the width of the shell cutout, in m (ft), plus 0.6 m (2 ft); and 3) the tank height, in m (ft).
- The design length of the girder shall be equal to the width of the shell cutout, in m (ft), plus 0.6 m (2 ft).

Note: When, because of wear, the difference in the diameters of the bolts and bolt holes is approximately 0.5 mm (0.020 in.), it is recommended that the holes be rereamed and fitted with oversize milled-body bolts; however, the holes shall not be reamed so much that the efficiency of the bolted connection becomes less than 0.85. This point is reached when the bolt-hole diameters become 6 mm (1/4 in.) larger than the bolt diameters specified in Tables A-5 and A-6.

100

100

**A.10.3** When a flush-type bolted door sheet is installed on a tank that is resting on an earth grade with or without a concrete retaining wall and without a concrete or masonry wall under the tank shell, provision shall be made to support the fitting and retain the grade as shown in Figure A-2, Method A.

**A.10.4** When a flush-type bolted door sheet is installed on a tank resting on a ringwall, a cutout with the dimensions shown in Figure A-2, Method B, shall be provided.

**A.10.5** Openings larger than NPS 2 nominal pipe size in flush-type bolted door sheets shall be reinforced in accordance with 3.7.2, and the reinforcement shall replace the cut-out area of the door plate.

### A.11 Raised-Type Bolted Door Sheets

Raised-type bolted door sheets shall conform to Figure A-3 and Table A-6.

Table A-6—Raised-Type Bolted Door Sheets (See Figure A-3)

(All dimensions in mm)						(All dimensions in inches)					
Column 1	Column 2	Column 3	Column 4	Column 5	Column 6	Column 1	Column 2	Column 3	Column 4	Column 5	Column 6
Shell Thickness $t_s$	$Q$	$q$	$h$	$j$	$K$	Shell Thickness $t_s$	$Q$	$q$	$h$	$j$	$K$
6	7	51	180	103.4	36	1/4	7	1 <sup>15</sup> / <sub>16</sub>	7.179	4.080	36
8	7	51	180	103.4	30	5/16	7	1 <sup>15</sup> / <sub>16</sub>	7.179	4.080	30
10	8	51	157.5	93.8	30	3/8	8	1 <sup>15</sup> / <sub>16</sub>	6.281	3.691	30
11	8	62	159	100.8	24	7/16	8	2 <sup>1</sup> / <sub>4</sub>	6.328	3.883	24
13	8	62	159	100.8	22	1/2	8	2 <sup>1</sup> / <sub>4</sub>	6.328	3.883	22

Column 7	Column 8	Column 9	Column 10	Column 11	Column 12	Column 7	Column 8	Column 9	Column 10	Column 11	Column 12
$k$	$t_D$	$h_D$	$L_D$	Number of Bolts		$k$	$t_D$	$h_D$	$L_D$	Number of Bolts	
				Row 1	Row 2					Row 1	Row 2
71.2	11	1320	3336	0	5	2.837	7/16	52 <sup>1</sup> / <sub>2</sub>	131 <sup>1</sup> / <sub>2</sub>	—	5
85.4	11	1320	3336	0	7	3.404	7/16	52 <sup>1</sup> / <sub>2</sub>	131 <sup>1</sup> / <sub>2</sub>	—	7
85.4	11	1320	3438	0	8	3.404	7/16	52 <sup>1</sup> / <sub>2</sub>	135 <sup>3</sup> / <sub>8</sub>	—	8
103	13	1332	3524	0	0	4.109	1/2	53 <sup>1</sup> / <sub>4</sub>	137 <sup>1</sup> / <sub>4</sub>	—	—
118	14	1332	3524	0	6	4.688	9/16	53 <sup>1</sup> / <sub>4</sub>	141 <sup>3</sup> / <sub>4</sub>	—	6

Column 13	Column 14	Column 15	Column 16	Column 17	Column 13	Column 14	Column 15	Column 16	Column 17
Number of Bolts Total	Bolt Diameter <sup>d</sup>	Bolt Length	Length of Bolt Thread	Square Locking Bar	Number of Bolts Total	Bolt Diameter <sup>d</sup>	Bolt Length	Length of Bolt Thread	Square Locking Bar
144	20	50	27	16	144	3/4	2	1 <sup>1</sup> / <sub>16</sub>	5/8
164	20	50	25	16	164	3/4	2	1	5/8
136	22	55	30	20	136	7/8	2 <sup>1</sup> / <sub>4</sub>	1 <sup>1</sup> / <sub>8</sub>	3/4
144	22	65	32	20	144	7/8	2 <sup>1</sup> / <sub>2</sub>	1 <sup>1</sup> / <sub>4</sub>	3/4

Note: Washers shall be used on both sides of the plate for shell thicknesses of 16 mm (5/8 in.) or less.

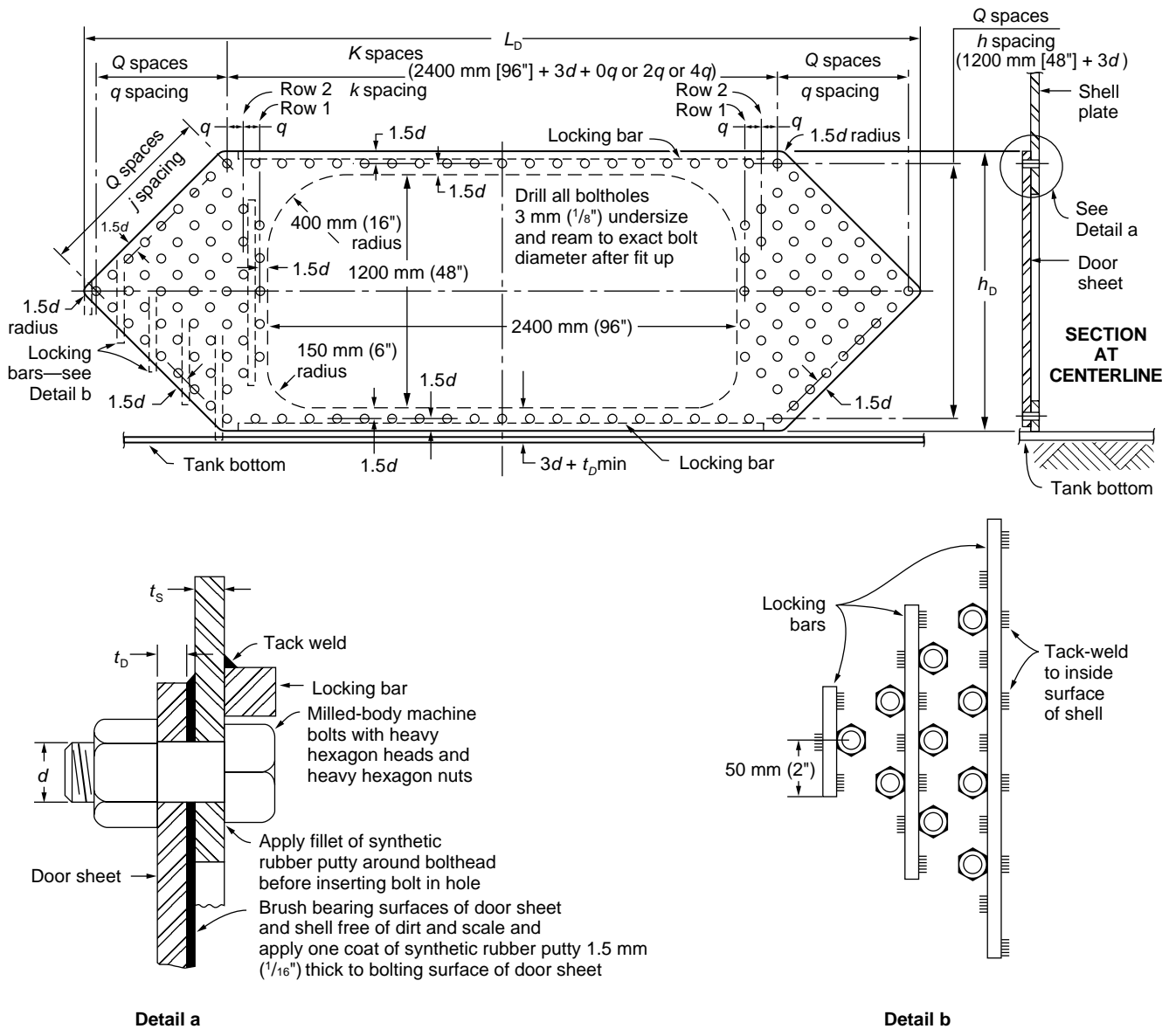

Figure A-3—Raised-Type Bolted Door Sheet (See Table A-6)



## APPENDIX B—RECOMMENDATIONS FOR DESIGN AND CONSTRUCTION OF FOUNDATIONS FOR ABOVEGROUND OIL STORAGE TANKS

### B.1 Scope

**B.1.1** This appendix provides important considerations for the design and construction of foundations for aboveground steel oil storage tanks with flat bottoms. Recommendations are offered to outline good practice and to point out some precautions that should be considered in the design and construction of storage tank foundations.

**B.1.2** Since there is a wide variety of surface, subsurface, and climatic conditions, it is not practical to establish design data to cover all situations. The allowable soil loading and the exact type of subsurface construction to be used must be decided for each individual case after careful consideration. The same rules and precautions shall be used in selecting foundation sites as would be applicable in designing and constructing foundations for other structures of comparable magnitude.

### B.2 Subsurface Investigation and Construction

**B.2.1** At any tank site, the subsurface conditions must be known to estimate the soil bearing capacity and settlement that will be experienced. This information is generally obtained from soil borings, load tests, sampling, laboratory testing, and analysis by an experienced geotechnical engineer familiar with the history of similar structures in the vicinity. The subgrade must be capable of supporting the load of the tank and its contents. The total settlement must not strain connecting piping or produce gauging inaccuracies, and the settlement should not continue to a point at which the tank bottom is below the surrounding ground surface. The estimated settlement shall be within the acceptable tolerances for the tank shell and bottom.

- **B.2.2** When actual experience with similar tanks and foundations at a particular site is not available, the following ranges for factors of safety should be considered for use in the foundation design criteria for determining the allowable soil bearing pressures. (The owner or geotechnical engineer responsible for the project may use factors of safety outside these ranges.)

- a. From 2.0 to 3.0 against ultimate bearing failure for normal operating conditions.
- b. From 1.5 to 2.25 against ultimate bearing failure during hydrostatic testing.
- c. From 1.5 to 2.25 against ultimate bearing failure for operating conditions plus the maximum effect of wind or seismic loads.

**B.2.3** Some of the many conditions that require special engineering consideration are as follows:

- a. Sites on hillsides, where part of a tank may be on undisturbed ground or rock and part may be on fill or another construction or where the depth of required fill is variable.
- b. Sites on swampy or filled ground, where layers of muck or compressible vegetation are at or below the surface or where unstable or corrosive materials may have been deposited as fill.
- c. Sites underlain by soils, such as layers of plastic clay or organic clays, that may support heavy loads temporarily but settle excessively over long periods of time.
- d. Sites adjacent to water courses or deep excavations, where the lateral stability of the ground is questionable.
- e. Sites immediately adjacent to heavy structures that distribute some of their load to the subsoil under the tank sites, thereby reducing the subsoil's capacity to carry additional loads without excessive settlement.
- f. Sites where tanks may be exposed to flood waters, possibly resulting in uplift, displacement, or scour.
- g. Sites in regions of high seismicity that may be susceptible to liquefaction.
- h. Sites with thin layers of soft clay soils that are directly beneath the tank bottom and that can cause lateral ground stability problems.

**B.2.4** If the subgrade is inadequate to carry the load of the filled tank without excessive settlement, shallow or superficial construction under the tank bottom will not improve the support conditions. One or more of the following general methods should be considered to improve the support conditions:

- a. Removing the objectionable material and replacing it with suitable, compacted material.
- b. Compacting the soft material with short piles.
- c. Compacting the soft material by preloading the area with an overburden of soil. Strip or sand drains may be used in conjunction with this method.
- d. Stabilizing the soft material by chemical methods or injection of cement grout.
- e. Transferring the load to a more stable material underneath the subgrade by driving piles or constructing foundation piers. This involves constructing a reinforced concrete slab on the piles to distribute the load of the tank bottom.
- f. Constructing a slab foundation that will distribute the load over a sufficiently large area of the soft material so that the load intensity will be within allowable limits and excessive settlement will not occur.

g. Improving soil properties by vibrocompaction, vibro-replacement, or deep dynamic compaction.

h. Slow and controlled filling of the tank during hydrostatic testing. When this method is used, the integrity of the tank may be compromised by excessive settlements of the shell or bottom. For this reason, the settlements of the tank shall be closely monitored. In the event of settlements beyond established ranges, the test may have to be stopped and the tank releveled.

**B.2.5** The fill material used to replace muck or other objectionable material or to build up the grade to a suitable height shall be adequate for the support of the tank and product after the material has been compacted. The fill material shall be free of vegetation, organic matter, cinders, and any material that will cause corrosion of the tank bottom. The grade and type of fill material shall be capable of being compacted with standard industry compaction techniques to a density sufficient to provide appropriate bearing capacity and acceptable settlements. The placement of the fill material shall be in accordance with the project specifications prepared by a qualified geotechnical engineer.

### B.3 Tank Grades

**B.3.1** The grade or surface on which a tank bottom will rest should be constructed at least 0.3 m (1 ft) above the surrounding ground surface. This will provide suitable drainage, help keep the tank bottom dry, and compensate for some small settlement that is likely to occur. If a large settlement is expected, the tank bottom elevation shall be raised so that the final elevation above grade will be a minimum of 150 mm (6 in.) after settlement.

**B.3.2** There are several different materials that can be used for the grade or surface on which the tank bottom will rest. To minimize future corrosion problems and maximize the effect of corrosion prevention systems such as cathodic protection, the material in contact with the tank bottom should be fine and uniform. Gravel or large particles shall be avoided. Clean washed sand 75 to 100 mm (3 to 4 in.) deep is recommended as a final layer because it can be readily shaped to the bottom contour of the tank to provide maximum contact area and will protect the tank bottom from coming into contact with large particles and debris. Large foreign objects or point contact by gravel or rocks could cause corrosion cells that will cause pitting and premature tank bottom failure.

During construction, the movement of equipment and materials across the grade will mar the graded surface. These irregularities should be corrected before bottom plates are placed for welding.

Adequate provisions, such as making size gradients in sub-layers progressively smaller from bottom to top, should be made to prevent the fine material from leaching down into the

larger material, thus negating the effect of using the fine material as a final layer. This is particularly important for the top of a crushed rock ringwall.

Note: For more information on tank bottom corrosion and corrosion prevention that relates to the foundation of a tank, see API Recommended Practice 651.

- **B.3.3** Unless otherwise specified by the owner, the finished tank grade shall be crowned from its outer periphery to its center at a slope of one inch in ten feet. The crown will partly compensate for slight settlement, which is likely to be greater at the center. It will also facilitate cleaning and the removal of water and sludge through openings in the shell or from sumps situated near the shell. Because crowning will affect the lengths of roof-supporting columns, it is essential that the tank manufacturer be fully informed of this feature sufficiently in advance. (For an alternative to this paragraph, see B.3.4.)
- **B.3.4** As an alternative to B.3.3, the tank bottom may be sloped toward a sump. The tank manufacturer must be advised as required in B.3.3.

## B.4 Typical Foundation Types

### B.4.1 EARTH FOUNDATIONS WITHOUT A RINGWALL

**B.4.1.1** When an engineering evaluation of subsurface conditions that is based on experience and/or exploratory work has shown that the subgrade has adequate bearing capacity and that settlements will be acceptable, satisfactory foundations may be constructed from earth materials. The performance requirements for earth foundations are identical to those for more extensive foundations. Specifically, an earth foundation should accomplish the following:

- a. Provide a stable plane for the support of the tank.
- b. Limit overall settlement of the tank grade to values compatible with the allowances used in the design of the connecting piping.
- c. Provide adequate drainage.
- d. Not settle excessively at the perimeter due to the weight of the shell wall.

**B.4.1.2** Many satisfactory designs are possible when sound engineering judgment is used in their development. Three designs are referred to in this appendix on the basis of their satisfactory long-term performance. For smaller tanks, foundations can consist of compacted crushed stone, screenings, fine gravel, clean sand, or similar material placed directly on virgin soil. Any unstable material must be removed, and any replacement material must be thoroughly compacted. Two recommended designs that include ringwalls are illustrated in Figures B-1 and B-2 and described in B.4.2 and B.4.3.

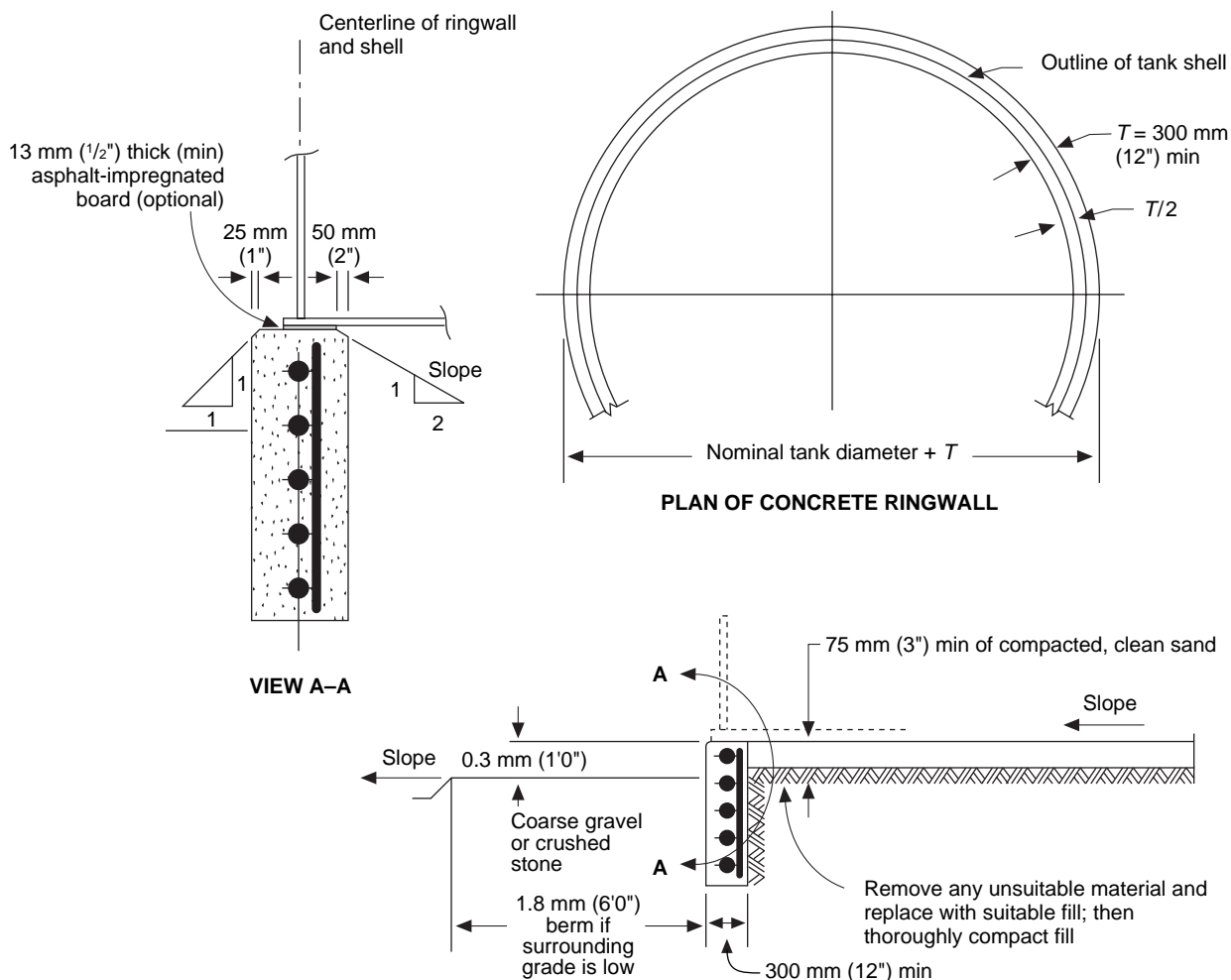

## Notes:

1. See B.4.2.3 for requirements for reinforcement.
2. The top of the concrete ringwall shall be smooth and level. The concrete strength shall be at least 20 MPa (3000 lbf/in.<sup>2</sup>) after 28 days. Reinforcement splices must be staggered and shall be lapped to develop full strength in the bond. If staggering of laps is not possible, refer to ACI 318 for additional development requirements.
3. Ringwalls that exceed 300 mm (12 in.) in width shall have rebars distributed on both faces.
4. See B.4.2.2 for the position of the tank shell on the ringwall.

Figure B-1—Example of Foundation With Concrete Ringwall

## B.4.2 EARTH FOUNDATIONS WITH A CONCRETE RINGWALL

**B.4.2.1** Large tanks, tanks with heavy or tall shells and/or self-supported roofs impose a substantial load on the foundation under the shell. This is particularly important with regard to shell distortion in floating-roof tanks. When there is some doubt whether a foundation will be able to carry the shell load directly, a concrete ringwall foundation should be used. As an alternative to the concrete ringwall noted in this section, a crushed stone ringwall (see B.4.3) may be used. A foundation with a concrete ringwall has the following advantages:

- a. It provides better distribution of the concentrated load of the shell to produce a more nearly uniform soil loading under the tank.
- b. It provides a level, solid starting plane for construction of the shell.
- c. It provides a better means of leveling the tank grade, and it is capable of preserving its contour during construction.
- d. It retains the fill under the tank bottom and prevents loss of material as a result of erosion.
- e. It minimizes moisture under the tank.

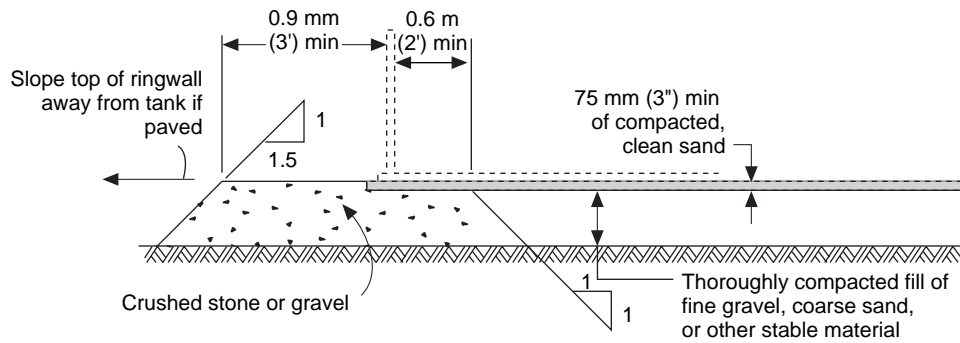

Note: Any unsuitable material shall be removed and replaced with suitable fill; the fill shall then be thoroughly compacted.

Figure B-2—Example of Foundation With Crushed Stone Ringwall

A disadvantage of concrete ringwalls is that they may not smoothly conform to differential settlements. This disadvantage may lead to high bending stresses in the bottom plates adjacent to the ringwall.

**B.4.2.2** When a concrete ringwall is designed, it shall be proportioned so that the allowable soil bearing is not exceeded. The ringwall shall not be less than 300 mm (12 in.) thick. The centerline diameter of the ringwall should equal the nominal diameter of the tank; however, the ringwall centerline may vary if required to facilitate the placement of anchor bolts or to satisfy soil bearing limits for seismic loads or excessive uplift forces. The depth of the wall will depend on local conditions, but the depth must be sufficient to place the bottom of the ringwall below the anticipated frost penetration and within the specified bearing strata. As a minimum, the bottom of the ringwall, if founded on soil, shall be located 0.6 m (2 ft) below the lowest adjacent finish grade. Tank foundations must be constructed within the tolerances specified in 5.5.5. Recesses shall be provided in the wall for flush-type cleanouts, drawoff sumps, and any other appurtenances that require recesses.

**B.4.2.3** A ringwall should be reinforced against temperature changes and shrinkage and reinforced to resist the lateral pressure of the confined fill with its surcharge from product loads. ACI 318 is recommended for design stress values, material specifications, and rebar development and cover. The following items concerning a ringwall shall be considered:

a. The ringwall shall be reinforced to resist the direct hoop tension resulting from the lateral earth pressure on the ringwall's inside face. Unless substantiated by proper geotechnical analysis, the lateral earth pressure shall be assumed to be at least 50% of the vertical pressure due to

fluid and soil weight. If a granular backfill is used, a lateral earth pressure coefficient of 30% may be used.

b. The ringwall shall be reinforced to resist the bending moment resulting from the uniform moment load. The uniform moment load shall account for the eccentricities of the applied shell and pressure loads relative to the centroid of the resulting soil pressure. The pressure load is due to the fluid pressure on the horizontal projection of the ringwall inside the shell.

c. The ringwall shall be reinforced to resist the bending and torsion moments resulting from lateral, wind, or seismic loads applied eccentrically to it. A rational analysis, which includes the effect of the foundation stiffness, shall be used to determine these moments and soil pressure distributions.

d. The total hoop steel area required to resist the loads noted above shall not be less than the area required for temperature changes and shrinkage. The hoop steel area required for temperature changes and shrinkage is 0.0025 times the vertical cross-sectional area of the ringwall or the minimum reinforcement for walls called for in ACI 318, Chapter 14.

e. For ringwalls, the vertical steel area required for temperature changes and shrinkage is 0.0015 times the horizontal cross-sectional area of the ringwall or the minimum reinforcement for walls called for in ACI 318, Chapter 14. Additional vertical steel may be required for uplift or torsional resistance. If the ring foundation is wider than its depth, the design shall consider its behavior as an annular slab with flexure in the radial direction. Temperature and shrinkage reinforcement shall meet the ACI 318 provisions for slabs. (See ACI 318, Chapter 7.)

f. When the ringwall width exceeds 460 mm (18 in.), using a footing beneath the wall should be considered. Footings may also be useful for resistance to uplift forces.

g. Structural backfill within and adjacent to concrete ringwalls and around items such as vaults, undertank piping, and sumps requires close field control to maintain settlement tolerances. Backfill should be granular material compacted to

the density and compacting as specified in the foundation construction specifications. For other backfill materials, sufficient tests shall be conducted to verify that the material has adequate strength and will undergo minimal settlement.

### **B.4.3 EARTH FOUNDATIONS WITH A CRUSHED STONE AND GRAVEL RINGWALL**

**B.4.3.1** A crushed stone or gravel ringwall will provide adequate support for high loads imposed by a shell. A foundation with a crushed stone or gravel ringwall has the following advantages:

- a. It provides better distribution of the concentrated load of the shell to produce a more nearly uniform soil loading under the tank.
- b. It provides a means of leveling the tank grade, and it is capable of preserving its contour during construction.
- c. It retains the fill under the tank bottom and prevents loss of material as a result of erosion.
- d. It can more smoothly accommodate differential settlement because of its flexibility.

A disadvantage of the crushed stone or gravel ringwall is that it is more difficult to construct it to close tolerances and achieve a flat, level plane for construction of the tank shell.

**B.4.3.2** For crushed stone or gravel ringwalls, careful selection of design details is necessary to ensure satisfactory

performance. The type of foundation suggested is shown in Figure B-2. Significant details include the following:

- a. The 0.9 m (3 ft) shoulder and berm shall be protected from erosion by being constructed of crushed stone or covered with a permanent paving material.
- b. Care shall be taken during construction to prepare and maintain a smooth, level surface for the tank bottom plates.
- c. The tank grade shall be constructed to provide adequate drainage away from the tank foundation.
- d. The tank foundation must be true to the specified plane within the tolerances specified in 5.5.5.

### **B.4.4 SLAB FOUNDATIONS**

- **B.4.4.1** When the soil bearing loads must be distributed over an area larger than the tank area or when it is specified by the owner, a reinforced concrete slab shall be used. Piles beneath the slab may be required for proper tank support.

**B.4.4.2** The structural design of the slab, whether on grade or on piles, shall properly account for all loads imposed upon the slab by the tank. The reinforcement requirements and the design details of construction shall be in accordance with ACI 318.

## **B.5 Tank Foundations for Leak Detection**

Appendix I provides recommendations on the construction of tank and foundation systems for the detection of leaks through the bottoms of storage tanks.



## APPENDIX C—EXTERNAL FLOATING ROOFS

### ● C.1 Scope

This appendix provides minimum requirements that, unless otherwise qualified in the text, apply to pan-type, pontoon-type, and double-deck-type floating roofs. This appendix is intended to limit only those factors that affect the safety and durability of the installation and that are considered to be consistent with the quality and safety requirements of this standard. Numerous alternative details and proprietary appurtenances are available; however, agreement between the purchaser and the manufacturer is required before they are used.

### C.2 Material

The material requirements of Section 2 shall apply unless otherwise stated in this appendix. Castings shall conform to any of the following specifications:

- a. ASTM A 27M, grade 405-205 (ASTM A 27, grade 60-30), fully annealed.
- b. ASTM A 27M, grade 450-240 (ASTM A 27, grade 65-35), fully annealed or normalized and tempered, or quenched and tempered.
- c. ASTM A 216M (ASTM A 216) WCA, WCB, or WCC grades annealed and normalized, or normalized and tempered.

### C.3 Design

#### ● C.3.1 GENERAL

The roof and accessories shall be designed and constructed so that the roof is allowed to float to the maximum design liquid level and then return to a liquid level that floats the roof well below the top of the tank shell without damage to any part of the roof, tank, or appurtenances. During such an occurrence, no manual attention shall be required to protect the roof, tank, or appurtenances. If a winds skirt or top-shell extension is used to contain the roof seals at the highest point of travel, appropriate alarm devices shall be provided to indicate that the liquid level in the tank has risen above the designed capacity height unless the tank shell has been designed for a liquid height to the top of the shell extension. The purchaser shall specify the indicator arrangement suitable for operating purposes. Emergency overflow openings may be provided to protect the tank and floating roof from damage.

#### C.3.2 JOINTS

Joints shall be designed as described in 3.1.

#### C.3.3 DECKS

**C.3.3.1** Roofs in corrosive service, such as covering sour crude oil, should be the contact type designed to eliminate the presence of any air-vapor mixture under the deck.

- **C.3.3.2** Unless otherwise specified by the purchaser, all deck plates shall have a minimum nominal thickness of 5 mm ( $3/16$  in.) (permissible ordering basis—37.4 kg/m<sup>2</sup>, 7.65 lbf/ft<sup>2</sup> of plate, 0.180-in. plate, or 7-gauge sheet).

**C.3.3.3** Deck plates shall be joined by continuous full-fillet welds on the top side. On the bottom side, where flexure can be anticipated adjacent to girders, support legs, or other relatively rigid members, full-fillet welds not less than 50 mm (2 in.) long on 250 mm (10 in.) centers shall be used on any plate laps that occur within 300 mm (12 in.) of any such members.

**C.3.3.4** Top decks of double-deck roofs and of pontoon sections, which are designed with a permanent slope for drainage, shall have a minimum slope of 1 in 64 ( $3/16$  in. in 12 in.) and shall preferably be lapped to provide the best drainage. Plate buckles shall be kept to a minimum.

#### C.3.4 PONTOON DESIGN

**C.3.4.1** Floating roofs shall have sufficient buoyancy to remain afloat on liquid with a specific gravity of 0.7 and with primary drains inoperative for the following conditions:

- a. 250 mm (10 in.) of rainfall in a 24-hour period with the roofs intact, except for double-deck roofs provided with emergency drains to keep water to a lesser volume that the roofs will safely support. Such emergency drains shall not allow the product to flow onto the roof.
- b. Single-deck and any two adjacent pontoon compartments punctured in single-deck pontoon roofs and any two adjacent compartments punctured in double-deck roofs, both roof types with no water or live load.

- **C.3.4.2** The pontoon portions of single-deck pontoon-type roofs shall be designed to have adequate strength to prevent permanent distortion when the center deck is loaded by its design rainwater (C.3.4.1, Item a) or when the center deck and two adjacent pontoons are punctured (C.3.4.1, Item b). If calculations are required by the purchaser, the allowable stress and stability criteria shall be jointly established by the purchaser and the manufacturer as part of the inquiry. Alternatively, a proof test simulating the conditions of C.3.4.1, with the roof floating on water, may be performed on the roof or on one of similar design that is of equal or greater diameter.

**C.3.4.3** Any penetration of the floating roof shall not allow product to flow onto the roof under design conditions.

### C.3.5 PONTOON OPENINGS

Each compartment shall be provided with a liquid-tight manhole. Manhole covers shall be provided with suitable hold-down fixtures (which may be of the quick-opening type) or with other means of preventing wind or fire-fighting hose streams from removing the covers. The top edge of the manhole necks shall be at an elevation that prevents liquid from entering the compartments under the conditions of C.3.4.

Each compartment shall be vented to protect against internal or external pressure. Vents may be in the manhole cover or the top deck of the compartment. The vents shall be at an elevation that prevents liquid from entering the compartment under the conditions of C.3.4 and shall terminate in a manner that prevents entry of rain and fire-fighting liquids.

### C.3.6 COMPARTMENTS

Compartment plates are radial or circumferential dividers forming compartments that provide flotation for the roof (see C.3.4). All internal compartment plates (or sheets) shall be single-fillet welded along all of their edges, and other welding shall be performed at junctions as required to make each compartment liquid tight. Each compartment shall be tested for tightness using internal pressure or a vacuum box and a soap solution or penetrating oil.

#### ● C.3.7 LADDERS

Unless otherwise specified by the purchaser, the floating roof shall be supplied with a ladder that automatically adjusts to any roof position so that access to the roof is always provided. The ladder shall be designed for full-roof travel, regardless of the normal setting of the roof-leg supports. If a rolling ladder is furnished, it shall have full-length handrails on both sides and shall be designed for a 4450 N (1000 lbf) midpoint load with the ladder in any operating position.

#### ● C.3.8 ROOF DRAINS

Primary roof drains shall be of the hose, jointed, or siphon type, as specified on the purchase order. A check valve shall be provided near the roof end of the hose and on jointed pipe drains on single-deck and pan-type roofs to prevent backflow of stored product if leakage occurs. Provisions shall be made to prevent kinking of the hose or pinching of the hose under the deck support legs. Hose drains shall be designed to permit their replacement without personnel entering the tank. The swing joints of pipe drains shall be packed to prevent leakage. The installation of either the hose or the pipe drain shall include the installation of the proper shell fittings for its oper-

ation and, if necessary, removal. The minimum-size drain shall be capable of preventing the roof from accumulating a water level greater than design at the maximum rainfall rate specified by the purchaser for the roof when the roof is floating at the minimum operating level; however, the drain shall not be smaller than NPS 3 for roofs with a diameter less than or equal 36 m (120 ft) or smaller than NPS 4 for roofs with a diameter greater than 36 m (120 ft).

#### ● C.3.9 VENTS

Suitable vents shall be provided to prevent overstressing of the roof deck or seal membrane. The purchaser should specify liquid withdrawal rates so that the fabricator may size the vacuum vents. Vents, bleeder valves, or other suitable means shall be adequate to evacuate air and gases from underneath the roof during initial filling.

### C.3.10 SUPPORTING LEGS

- **C.3.10.1** The floating roof shall be provided with supporting legs. Legs fabricated from pipe shall be notched or perforated at the bottom to provide drainage. The length of the legs shall be adjustable from the top side of the roof. The operating- and cleaning-position levels of the supporting legs shall be as specified on the purchase order. The manufacturer shall make certain that all tank appurtenances, such as mixers, interior piping, and the fill nozzle, are cleared by the roof in its lowest position.

**C.3.10.2** The legs and attachments shall be designed to support the roof and a uniform live load of at least 1.2 kPa (25 lbf/ft<sup>2</sup>). Where possible, the roof load shall be transmitted to the legs through bulkheads or diaphragms. Leg attachments to single decks shall be given particular attention to prevent failures at the points of attachment. Steel pads or other means shall be used to distribute the leg loads on the bottom of the tank. If pads are used, they shall be continuously welded to the bottom.

#### ● C.3.11 ROOF MANHOLES

At least one roof manhole shall be provided for access to the tank interior and for ventilation when the tank is empty. The number of roof manholes shall be as specified by the purchaser. Each manhole shall have a minimum nominal diameter of 600 mm (24 in.) and shall have a tight-gasketed, bolted cover equivalent to the cover shown in Figure 3-13.

### C.3.12 CENTERING AND ANTIROTATION DEVICES

Suitable devices shall be provided to maintain the roof in a centered position and to prevent it from rotating. These devices shall be capable of resisting the lateral forces imposed by the roof ladder, unequal snow loads, and wind loads.

**● C.3.13 SEALS**

The space between the outer periphery of the roof and the tank shell shall be sealed by a flexible device that provides a reasonably close fit to the shell surfaces. If the sealing device employs steel shoes in contact with the shell, such shoes shall be made from galvanized sheet conforming to ASTM A 924 with a minimum nominal thickness of 1.5 mm (16 gauge) and a G90 coating. If uncoated shoes are specified, they shall be made from sheet steel with the thickness and quality specified on the purchase order. An adequate but minimum number of expansion joints shall be provided. Any fabric or nonmetallic material used as a seal or seal component shall be durable in its environment and shall not discolor or contaminate the product stored.

API Recommended Practice 2003 should be consulted regarding the possible need for bonding shunts between the roof and the metallic shoes. Provision for such shunts shall be a subject for agreement between the purchaser and the manufacturer.

**● C.3.14 GAUGING DEVICE**

Each roof shall be provided with a gauge hatch or gauge well with a tight cap that complies with the design specified in the purchase order.

**C.4 Fabrication, Erection, Welding, Inspection, and Testing**

**C.4.1** The applicable fabrication, erection, welding, inspection, and testing requirements of this standard shall apply.

**C.4.2** Deck seams and other joints that are required to be liquid or vapor tight shall be tested for leaks by means of penetrating oil or any other method consistent with the methods described in this standard for testing cone-roof seams and tank-bottom seams.

**C.4.3** The roof shall be given a flotation test while the tank is being filled with water and emptied. During this test, the upper side of the lower deck shall be examined for leaks. The appearance of a damp spot on the upper side of the lower deck shall be considered evidence of leakage.

**C.4.4** The upper side of the upper decks of pontoon and double-deck roofs shall be visually inspected for pinholes and defective welding.

**C.4.5** Drainpipe and hose systems of primary drains shall be tested with water at a pressure of 350 kPa (50 lbf/in.<sup>2</sup>) gauge. During the flotation test, the roof drain valves shall be kept open and observed for leakage of the tank contents into the drain lines.



## APPENDIX D—TECHNICAL INQUIRIES

### D.1 Introduction

API will consider written requests for interpretations of API Standard 650. API staff will make such interpretations in writing after consulting, if necessary, with the appropriate committee officers and committee members. The API committee responsible for maintaining API Standard 650 meets regularly to consider written requests for interpretations and revisions and to develop new criteria dictated by technological development. The committee's activities in this regard are limited strictly to interpretations of the standard and to the consideration of revisions to the present standard on the basis of new data or technology. As a matter of policy, API does not approve, certify, rate, or endorse any item, construction, proprietary device, or activity, and accordingly, inquiries that require such consideration will be returned. Moreover, API does not act as a consultant on specific engineering problems or on the general understanding or application of the standard. If, based on the inquiry information submitted, it is the opinion of the committee that the inquirer should seek other assistance, the inquiry will be returned with the recommendation that such assistance be obtained. All inquiries that cannot be understood because they lack information will be returned.

### D.2 Inquiry Format

**D.2.1** Inquiries shall be limited strictly to requests for interpretation of the standard or to the consideration of revisions to the standard on the basis of new data or technology. Inquiries shall be submitted in the format described in D.2.2 through D.2.5.

**D.2.2** The scope of an inquiry shall be limited to a single subject or a group of closely related subjects. An inquiry concerning two or more unrelated subjects will be returned.

**D.2.3** An inquiry shall start with a background section that states the purpose of the inquiry, which would be either to obtain an interpretation of the standard or to propose a revision to the standard. The background section shall concisely provide the information needed for the committee's understanding of the inquiry (with sketches as necessary) and shall cite the applicable edition, revision, paragraphs, figures, and tables.

**D.2.4** After the background section, an inquiry's main section shall state the inquiry as a condensed, precise question, omitting superfluous background information and, where appropriate, posing the question so that the reply could take the form of "yes" or "no" (perhaps with provisos). This inquiry statement should be technically and editorially correct. The inquirer shall state what he or she believes the standard requires. If the inquirer believes a revision to the standard is needed, he or she shall provide recommended wording.

**D.2.5** The inquirer shall include his or her name and mailing address. The inquiry should be typed; however, legible handwritten inquiries will be considered. Inquiries should be submitted to the general manager of the Downstream Segment, American Petroleum Institute, 1220 L Street, N.W., Washington, D.C. 20005.



## APPENDIX E—SEISMIC DESIGN OF STORAGE TANKS

### ● E.1 Scope

This appendix provides minimum requirements that may be specified by the purchaser for the design of storage tanks subject to seismic load. These requirements represent accepted practice for application to flat-bottom tanks; however, other procedures and applicable factors or additional requirements may be specified by the purchaser or jurisdictional authorities. Any deviation from the requirements of this appendix must be by agreement between the purchaser and the manufacturer.

Note: The basis for these requirements, together with the formulas for the design curves in Figures E-2 through E-5 and information for calculating other seismic effects, is included in a paper by R. S. Wozniak and W. W. Mitchell, "Basis of Seismic Design Provisions for Welded Steel Oil Storage Tanks."<sup>14</sup>

### E.2 General

The design procedure considers two response modes of the tank and its contents:

- The relatively high-frequency amplified response to lateral ground motion of the tank shell and roof, together with the portion of the liquid contents that moves in unison with the shell.
- The relatively low-frequency amplified response of the portion of the liquid contents that moves in the fundamental sloshing mode.

The design requires the determination of the hydrodynamic mass associated with each mode and the lateral force and overturning moment applied to the shell as a result of the response of the masses to lateral ground motion. Provisions are included to assure stability of the tank shell with respect to overturning and to preclude buckling of the tank shell as a result of longitudinal compression.

This appendix has no provisions for determining the increased hoop tension that would result from earthquake motion. The increased hoop tension, correctly calculated from the lateral force coefficients specified in this appendix, would not increase the hoop stresses above a generally acceptable stress level that could be used for seismic design of the tank shell.

### E.3 Design Loading

#### E.3.1 OVERTURNING MOMENT

Note: The overturning moment determined in E.3.1 is the moment applied to the bottom of the shell only. The tank foundation is sub-

jected to an additional overturning moment as a result of lateral displacement of the tank contents; this additional moment may need to be considered in the design of some foundations, such as pile-supported concrete mats.

The overturning moment due to seismic forces applied to the bottom of the shell shall be determined as follows:

$$M = ZI (C_1 W_S X_S + C_1 W_r H_t + C_1 W_1 X_1 + C_2 W_2 X_2)$$

where

$M$  = overturning moment applied to the bottom of the tank shell, in N-m (ft-lbf),

- $Z$  = seismic zone factor (horizontal seismic acceleration) as determined by the purchaser or the appropriate government authority that has jurisdiction. The seismic zone maps of Figure E-1, the seismic zone tabulation for areas outside the United States (see Table E-1), or the *Supplement to National Building Code of Canada* may be used as an aid to determine the seismic zone. Table E-2 can be used to determine the seismic zone factor,  $Z$ ,

- $I$  = importance factor,  
= 1.0 for all tanks unless a larger importance factor is specified by the purchaser. The  $I$  factor should not exceed 1.25, and this maximum value should be applied only to tanks that must provide emergency post-earthquake service or to tanks that store toxic or explosive substances in areas where an accidental release of product would be considered to be dangerous to the safety of the general public,

$C_1, C_2$  = lateral earthquake force coefficients determined according to E.3.3,

$W_S$  = total weight of the tank shell, in N (lbf),

$X_S$  = height from the bottom of the tank shell to the shell's center of gravity, in m (ft),

- $W_r$  = total weight of the tank roof (fixed or floating) plus a portion of the snow load, if any, specified by the purchaser, in N (lbf),

$H_t$  = total height of the tank shell, in m (ft),

$W_1$  = weight of the effective mass of the tank contents that move in unison with the tank shell, as determined according to E.3.2.1, in N (lbf),

$X_1$  = height from the bottom of the tank shell to the centroid of lateral seismic force applied to  $W_1$ , as determined according to E.3.2.2, in m (ft),

$W_2$  = weight of the effective mass of the tank contents that move in the first sloshing mode, as determined according to E.3.2.1, in N (lbf),

$X_2$  = height from the bottom of the tank shell to the centroid of lateral seismic force applied to  $W_2$ , as determined according to E.3.2.2, in m (ft).

<sup>14</sup>R. S. Wozniak and W. W. Mitchell, "Basis of Seismic Design Provisions for Welded Steel Oil Storage Tanks," *1978 Proceedings—Refining Department*, Volume 57, American Petroleum Institute, Washington, D.C., 1978, pp. 485–501.

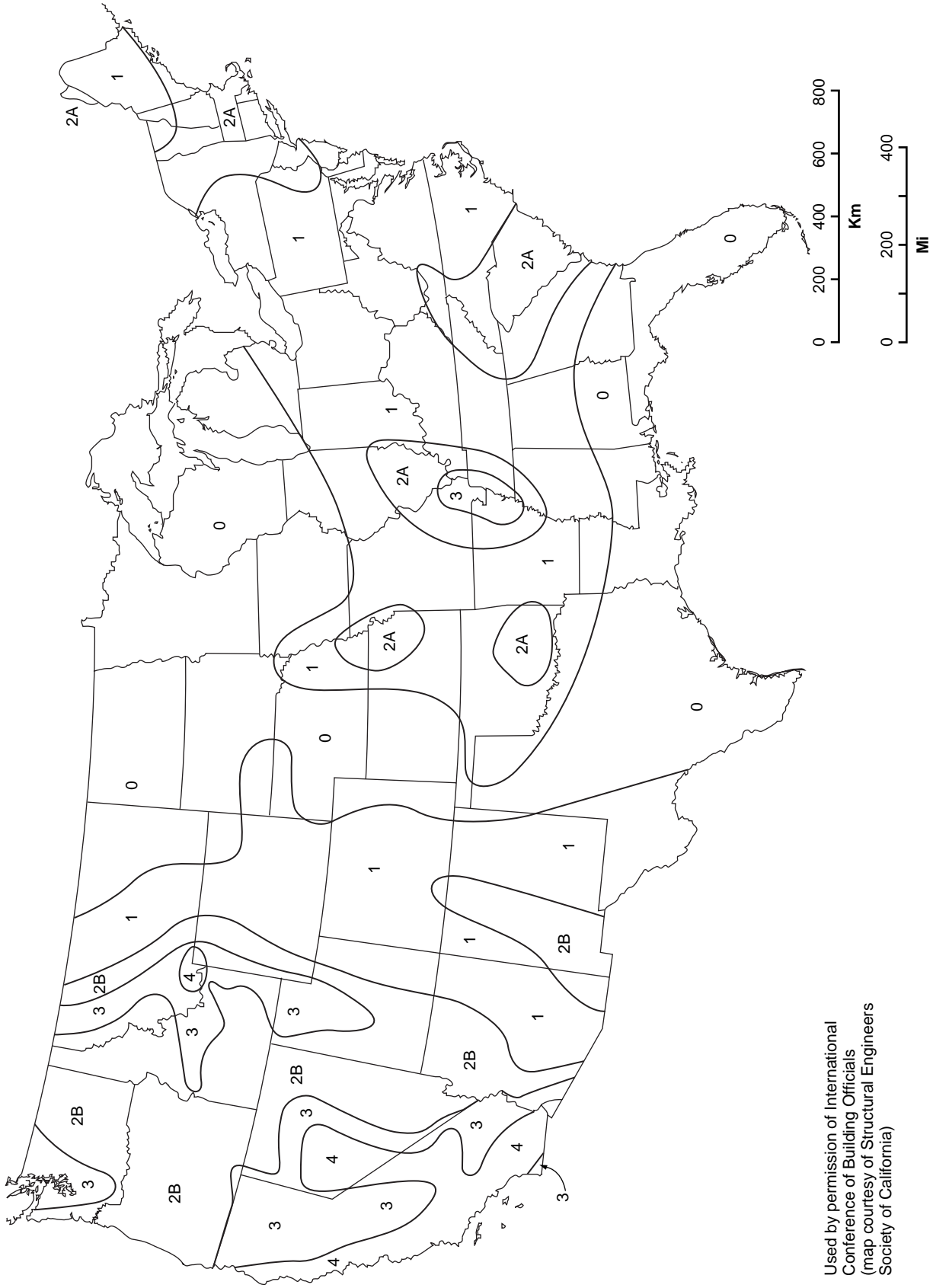

Used by permission of International  
Conference of Building Officials  
(map courtesy of Structural Engineers  
Society of California)

Figure E-1—Seismic Zones

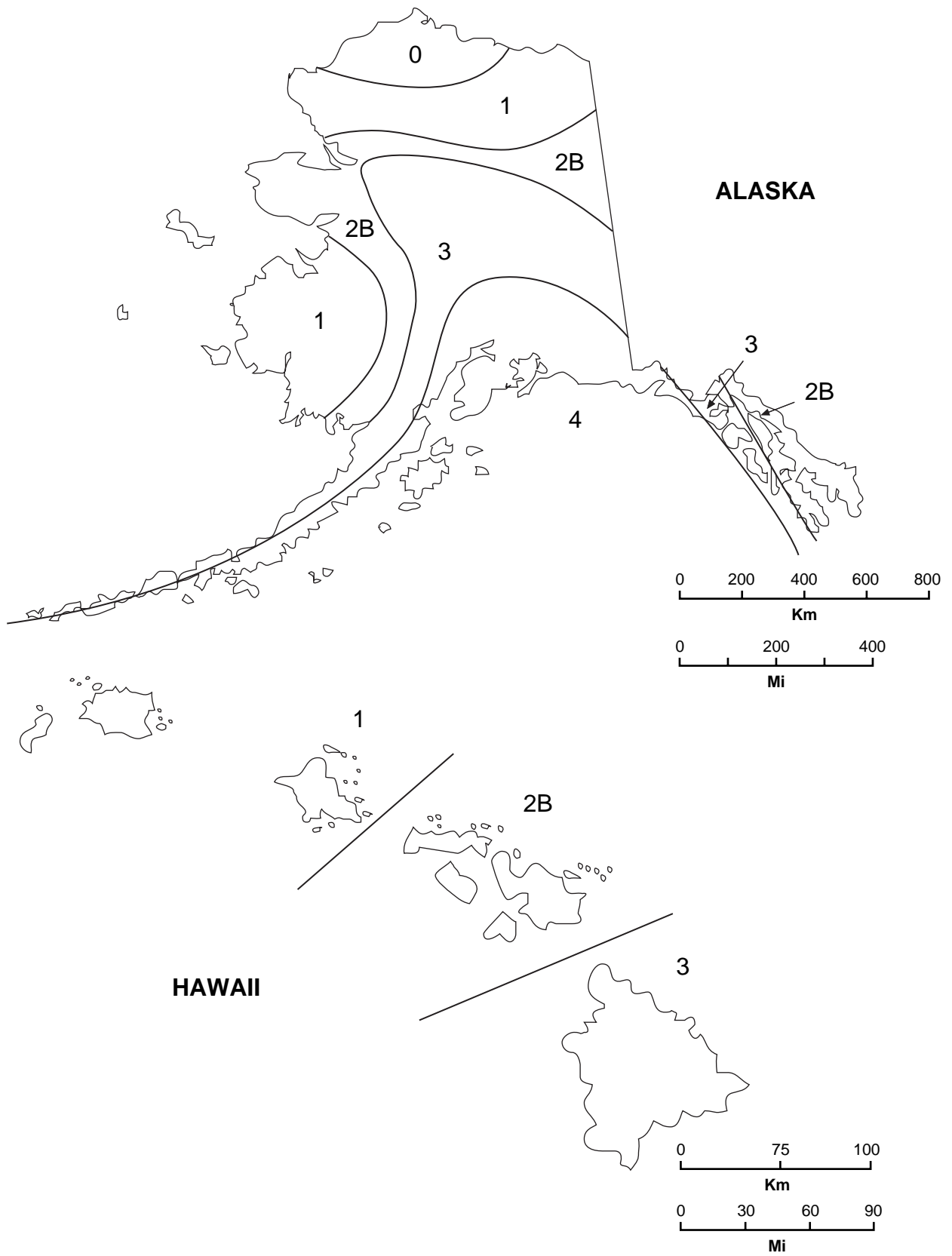

Figure E-1—Seismic Zones (continued)

Table E-1—Seismic Zone Tabulation for Areas Outside the United States

Location	Seismic Zone	Location	Seismic Zone
Asia		Pacific Ocean area	
Turkey		Caroline Islands	
Ankara	2B	Koror, Paulau	2B
Karamursel	3	Ponape	0
Atlantic Ocean area		Johnston Island	1
Azores	2B	Kwajalein	1
Bermuda	1	Mariana Island	
Caribbean		Guam	3
Bahama Islands	1	Saipan	3
Canal Zone	2B	Tinain	3
Leeward Islands	3	Marcus Island	1
Puerto Rico	3	Okinawa	3
Trinidad Island	2B	Philippine Islands	3
North America		Samoa Islands	3
Greenland	1	Wake Island	0
Iceland			
Keflavik	3		

### E.3.2 EFFECTIVE MASS OF TANK CONTENTS

**E.3.2.1** The effective masses  $W_1$  and  $W_2$  may be determined by multiplying  $W_T$  by the ratios  $W_1/W_T$  and  $W_2/W_T$ , respectively, obtained from Figure E-2 for the ratio  $D/H$ .

where

- $W_T$  = total weight of the tank contents, in pounds. (The specific gravity of the product shall be specified by the purchaser.),
- $D$  = nominal tank diameter, in m (ft) (see 3.6.1.1, Note 1),
- $H$  = maximum design liquid level, in m (ft) (see 3.6.3.2).

**E.3.2.2** The heights from the bottom of the tank shell to the centroids of the lateral seismic forces applied to  $W_1$  and  $W_2$ ,  $X_1$  and  $X_2$ , may be determined by multiplying  $H$  by the ratios  $X_1/H$  and  $X_2/H$ , respectively, obtained from Figure E-3 for the ratio  $D/H$ .

**E.3.2.3** The curves in Figures E-2 and E-3 are based on a modification of the equations presented in ERDA Technical Information Document 7024.<sup>15</sup> Alternatively,  $W_1$ ,  $W_2$ ,  $X_1$ , and  $X_2$  may be determined by other analytical procedures based on the dynamic characteristics of the tank.

### E.3.3 LATERAL FORCE COEFFICIENTS

**E.3.3.1** The lateral force coefficient  $C_1$  shall be 0.60 unless the product of  $ZIC_1$  and the product of  $ZIC_2$  are determined as outlined in E.3.3.3.

<sup>15</sup>ERDA Technical Information Document 7024, *Nuclear Reactors and Earthquakes* (prepared by Lockheed Aircraft Corporation and Holmes & Narver, Inc.), U.S. Atomic Energy Commission, August 1963.

Table E-2—Seismic Zone Factor

Seismic Factor (from Figure E-1 or other sources)	Seismic Zone Factor (horizontal acceleration)
1	0.075
2A	0.15
2B	0.20
3	0.30
4	0.40

**E.3.3.2** The lateral force coefficient  $C_2$  shall be determined as a function of the natural period of the first sloshing mode,  $T$ , and the soil conditions at the tank site unless otherwise determined by the method given in E.3.3.3. When  $T$  is less than or equal to 4.5,

$$C_2 = \frac{0.75S}{T}$$

When  $T$  is greater than 4.5,

$$C_2 = \frac{3.375S}{T^2}$$

where

$S$  = site coefficient from Table E-3,

$T$  = natural period of the first sloshing mode, in seconds.  $T$  may be determined from the following equation:

In SI units:

$$T = 1.81k(D^{0.5})$$

where  $D$  = nominal tank diameter in m.

In U.S. Customary units:

$$T = k(D^{0.5})$$

where  $D$  = nominal tank diameter in ft.

$k$  = factor obtained from Figure E-4 for the ratio  $D/H$ .

- **E.3.3.3** Alternatively, by agreement between the purchaser and the manufacturer, the lateral force determined by the products of  $ZIC_1$  and  $ZIC_2$  may be determined from response spectra established for the specific tank site and furnished by the purchaser; however, the lateral force  $ZIC_1$  shall not be less than that determined in accordance with E.3.1 and E.3.3.1.

The response spectra for a specific site should be established considering the active faults within the region, the types of faults, the magnitude of the earthquake that could be generated by each fault, the regional seismic activity rate, the proximity of the site to the potential source faults, the attenuation of the ground motion between the faults and the site, and the soil conditions at the site. The spectrum for the factor  $ZIC_1$  should be established for a damping coefficient of 2% of critical. Scaling of the response spectrum to account for the reserve capacity of the tank is permissible. The acceptable reserve capacity shall be specified by the purchaser and can be determined from table tests, field observations, and the ductility of the structure.

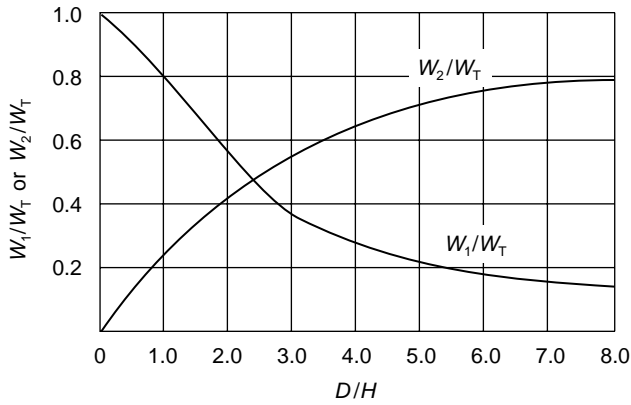

Figure E-2—Effective Masses

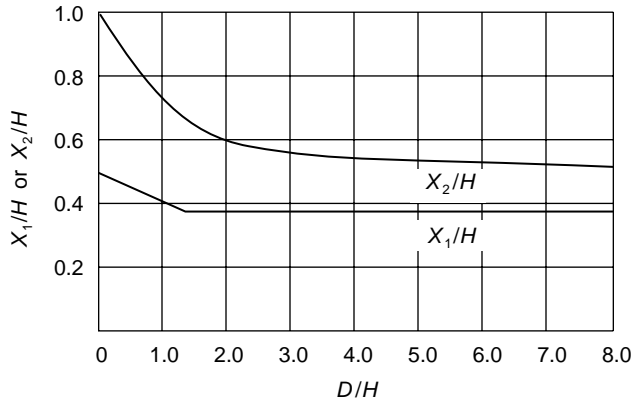

Figure E-3—Centroids of Seismic Forces

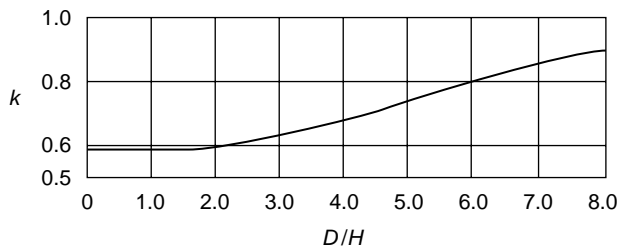

Figure E-4—Factor k

The spectrum for the factor  $ZIC_2$  should correspond to the spectrum for  $ZIC_1$  modified for a damping coefficient of 0.5% of critical. In determining the factor  $ZIC_1$  from the spectrum, the fundamental period of the tank with its contents shall be taken into account unless the maximum spectral acceleration is used.

### E.4 Resistance to Overturning

**E.4.1** Resistance to the overturning moment at the bottom of the shell may be provided by the weight of the tank shell and by the anchorage of the tank shell or, for unanchored tanks, the weight of a portion of the tank contents adjacent to the shell. For unanchored tanks, the portion of the contents that may be used to resist overturning depends on the width of the bottom plate under the shell that lifts off the foundation and may be determined as follows:

In SI units:

$$w_L = 99t_b\sqrt{F_{by}GH}$$

However,  $w_L$  shall not exceed  $196GHD$

where

$w_L$  = maximum weight of the tank contents that may be used to resist the shell overturning moment, in N/m of shell circumference,

$t_b$  = thickness of the bottom plate under the shell, in mm, used to calculate  $w_L$  (see E.4.2),

$F_{by}$  = minimum specified yield strength of the bottom plate under the shell, MPa,

- $G$  = design specific gravity of the liquid to be stored, as specified by the purchaser,

$H$  = maximum design liquid level, m (see 3.6.3.2),

$D$  = nominal tank diameter, m (see 3.6.1.1, Note 1).

In U.S. Customary units:

$$w_L = 7.9t_b\sqrt{F_{by}GH}$$

However,  $w_L$  shall not exceed  $1.25GHD$

where

$w_L$  = maximum weight of the tank contents that may be used to resist the shell overturning moment, in lbf/ft of shell circumference,

$t_b$  = thickness of the bottom plate under the shell in inches, used to calculate  $w_L$  (see E.4.2),

$F_{by}$  = minimum specified yield strength of the bottom plate under the shell (lbf/in.<sup>2</sup>),

- $G$  = design specific gravity of the liquid to be stored, as specified by the purchaser,

$H$  = maximum design liquid level (ft) (see 3.6.3.2),

$D$  = nominal tank diameter (ft) (see 3.6.1.1, Note 1).

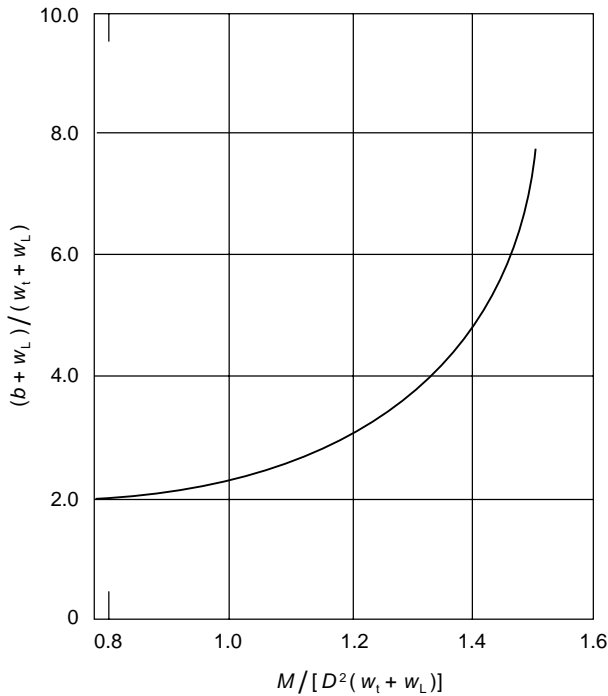

Note: This figure may be used to compute  $b$  when  $M / [D^2(w_t + w_L)]$  is greater than 0.785 but less than or equal to 1.5 (see E.5.1).

Figure E-5—Compressive Force  $b$

**E.4.2** The thickness of the bottom plate under the shell may be greater than or equal to  $t_b$ , but the thickness,  $t_b$ , used to calculate  $w_L$  shall not exceed the larger of 6 mm ( $1/4$  in.) or the first shell course thickness less the shell corrosion allowance, nor shall  $t_b$  exceed the actual thickness of the bottom plate under the shell less the corrosion allowance for the bottom plate. Where the bottom plate under the shell is thicker than the remainder of the bottom, the width of the thicker plate under the shell shall be equal to or greater than:

In SI units:

$$0.1745 \times 10^{-3} w_L / GH \text{ (m)}$$

In U.S. Customary units:

$$0.0274 \times 10^{-3} w_L / GH \text{ (ft)}$$

## E.5 Shell Compression

### E.5.1 UNANCHORED TANKS

For unanchored tanks, the maximum longitudinal compressive force at the bottom of the shell may be determined as follows: When  $M / [D^2(w_t + w_L)]$  is less than or equal to 0.785,

$$b = w_t + \frac{1.273M}{D^2}$$

When  $M / [D^2(w_t + w_L)]$  is greater than 0.785 but less than or equal to 1.5,  $b$  may be computed from the value of the following parameter obtained from Figure E-5:

Table E-3—Site Coefficients (See Note)

Type	Description	S Factor
$S_1$	A soil profile with either a) a rock-like material characterized by a shear wave velocity greater than 760 m/sec (2500 ft/sec) or by other suitable means of classification or b) stiff or dense soil conditions where the soil depth is less than 60 m (200 ft).	1.0
$S_2$	A soil profile with stiff or dense soil conditions where the soil depth exceeds 60 m (200 ft).	1.2
$S_3$	A soil profile 12 m (40 ft) or more in depth containing more than 6 m (20 ft) of soft to medium stiff clay but more than 12 m (40 ft) of soft clay.	1.5
$S_4$	A soil profile containing more than 12 m (40 ft) of soft clay.	2.0

Note: The site factor shall be established from properly substantiated geotechnical data. In locations where the soil properties are not known in sufficient detail to determine the soil profile type, soil profile  $S_3$  shall be used. Soil profile  $S_4$  need not be assumed unless the building official determines that soil profile  $S_4$  may be present at the site or in the event that soil profile  $S_4$  is established by geotechnical data.

$$\frac{b + w_L}{w_t + w_L}$$

When  $M / [D^2(w_t + w_L)]$  is greater than 1.5 but less than or equal to 1.57,

$$\frac{b + w_L}{w_t + w_L} = \frac{1.490}{\left[1 - \frac{0.637M}{D^2(w_t + w_L)}\right]^{0.5}}$$

where

- $b$  = maximum longitudinal compressive force at the bottom of the shell, in N/m (lbf/ft) of shell circumference,
- $w_t$  = weight of the tank shell and the portion of the fixed roof supported by the shell, in N/m (lbf/ft) of shell circumference.

When  $M / [D^2(w_t + w_L)]$  is greater than 1.57 or when  $b/1000t$  ( $b/12t$ ) is greater than  $F_a$  (see E.5.3), the tank is structurally unstable. It is then necessary to take one of the following measures:

- a. Increase the thickness of the bottom plate under the shell,  $t_b$ , to increase  $w_L$  without exceeding the limitations of E.4.1 and E.4.2.
- b. Increase the shell thickness,  $t$ .
- c. Change the proportions of the tank to increase the diameter and reduce the height.
- d. Anchor the tank in accordance with E.6.

### E.5.2 ANCHORED TANKS

For anchored tanks, the maximum longitudinal compressive force at the bottom of the shell may be determined as follows:

$$b = w_t + \frac{1.273M}{D^2}$$

### E.5.3 MAXIMUM ALLOWABLE SHELL COMPRESSION

00 | The maximum longitudinal compressive stress in the shell,  $b/1000t$  ( $b/12t$ ), shall not exceed the maximum allowable stress,  $F_a$ , determined by the following formulas for  $F_a$ , which take into account the effect of internal pressure due to the liquid contents. When  $GHD^2/t^2$  is greater than or equal to 44 (SI units) [ $10^6$  U.S. Customary Units)],

In SI units:

$$F_a = \frac{83t}{D}$$

When  $GHD^2/t^2$  is less than 44,

00 | 
$$F_a = \frac{83t}{2.5D} + 7.5\sqrt{GH}$$

However,  $F_a$  shall not be greater than  $0.5F_{ty}$

where

- $G$  = design specific gravity of the liquid to be stored, as specified by the purchaser,
- $H$  = maximum design liquid level, m (see 3.6.3.2),
- $D$  = nominal tank diameter, m (see 3.6.1.1, Note 1).
- $t$  = thickness of the bottom shell course, excluding any corrosion allowance, in mm.
- $F_a$  = maximum allowable longitudinal compressive stress in the shell, in MPa.
- $F_{ty}$  = minimum specified yield strength of the bottom shell course, in MPa.

In U.S. Customary units:

$$F_a = \frac{10^6 t}{D}$$

When  $GHD^2/t^2$  is less than  $10^6$ ,

00 | 
$$F_a = \frac{10^6 t}{2.5D} + 600\sqrt{GH}$$

However,  $F_a$  shall not be greater than  $0.5F_{ty}$

where

- $G$  = design specific gravity of the liquid to be stored, as specified by the purchaser,
- $H$  = maximum design liquid level (ft) (see 3.6.3.2),
- $D$  = nominal tank diameter (ft) (see 3.6.1.1, Note 1),
- $t$  = thickness of the bottom shell course, excluding any corrosion allowance (in.),
- $F_a$  = maximum allowable longitudinal compressive stress in the shell (lbf/in.<sup>2</sup>),
- $F_{ty}$  = minimum specified yield strength of the bottom shell course (lbf/in.<sup>2</sup>).

### E.5.4 UPPER SHELL COURSES

If the thickness of the lower shell course calculated to resist the seismic overturning moment is greater than the thickness required for hydrostatic pressure, both excluding any corrosion allowance, then the calculated thickness of each upper shell course for hydrostatic pressure shall be increased in the same proportion, unless a special analysis is made to determine the seismic overturning moment and corresponding stresses at the bottom of each upper shell course.

## E.6 Anchorage of Tanks

### E.6.1 MINIMUM ANCHORAGE

When tanks are anchored, then  $w_L$  (see E.4.1) shall not be used to reduce the uplifting load on the anchors. The anchors shall be sized to provide for at least the following minimum anchorage resistance, in N/m (lbf/ft) of shell circumference:

$$\frac{1.273M}{D^2} - w_i$$

plus any uplift, in N/m (lbf/ft) of shell circumference, due to internal design pressure. Wind loading need not be considered in combination with seismic loading. The stresses due to anchor forces in the tank shell at the points where the anchors are attached shall be investigated. (For a design procedure, see AISI E-1, Volume II, Part VII, "Anchor Bolt Chairs.")

### E.6.2 DESIGN CONSIDERATIONS

**E.6.2.1** If an anchored tank is not properly designed, its shell can be susceptible to tearing. Care should be taken to ensure that the strength of the anchorage attachments is greater than the specified minimum yield strength of the anchors so that the anchors yield before the attachments fail. Experience has shown that properly designed anchored tanks retain greater reserve strength with respect to seismic overload than unanchored tanks retain. In addition to the requirements of E.6.1, anchor design shall take into account the requirements of E.6.2.2 through E.6.2.7.

**E.6.2.2** The spacing between anchors shall not exceed 3 m (10 ft). On tanks less than 15 m (50 ft) in diameter, the spacing between anchors shall not exceed 1.8 m (6 ft). When anchor bolts are used, they shall have a minimum diameter of 25 mm (1 in.), excluding any corrosion allowance.

**E.6.2.3** The maximum allowable stress for the anchorage parts shall not exceed the following values:

- a. For anchors designed for seismic loading alone or in combination with other loading, an allowable tensile stress equal to 0.80 yield stress (0.60 of yield stress multiplied by 1.33).
- b. For other parts, 133% of the allowable stress in accordance with 3.10.3.

c. The maximum allowable design stress in the shell at the anchor attachment shall be limited to 170 MPa (25,000 psi) with no increase for seismic loading.

These stresses can be used in conjunction with other loads for seismic loading when the combined loading governs.

**E.6.2.4** The anchor attachment assembly and the attachment to the shell shall be designed for a load equal to the minimum specified yield strength multiplied by the as-built minimum cross-sectional area of the anchor.

**E.6.2.5** The embedment strength of the anchor in the foundation shall be sufficient to develop the specified minimum yield strength of the anchor. Hooked anchors or end plates may be used to resist pullout.

- **E.6.2.6** The purchaser should specify any corrosion allowance that is to be added to the anchor dimensions. The furnished anchors, including their corrosion allowance, shall be used to determine the design loads for the shell attachment and embedment requirements.
- **E.6.2.7** When specified by the purchaser, the anchors shall be designed to allow for thermal expansion of the tank resulting from a shell temperature greater than 90°C (200°F).

## E.7 Piping

Suitable flexibility shall be provided in the vertical direction for all piping attached to the shell or to the bottom of the

tank. On unanchored tanks subject to bottom uplift, piping connected to the bottom shall be free to lift with the bottom or shall be located so that the horizontal distance measured from the shell to the edge of the connecting reinforcement is equal to the width of the bottom hold-down, as calculated in E.4.2, plus 300 mm (12 in.).

## E.8 Additional Considerations

- **E.8.1** The purchaser shall specify any freeboard desired to minimize or prevent overflow and damage to the roof and upper shell that may be caused by sloshing of the liquid contents.
- **E.8.2** The base of the roof-supporting columns shall be restrained to prevent lateral movement during earthquakes. When specified by the purchaser, the columns shall be designed to resist the forces caused by sloshing of the liquid contents.
- **E.8.3** The additional vertical forces at the shell caused by the seismic overturning moment shall be considered in the design of the tank foundation.

**E.8.4** Unless otherwise required, tanks that may be subject to sliding due to earthquake shall use a maximum allowable sliding friction of 0.40 multiplied by the force against the tank bottom.

## APPENDIX F—DESIGN OF TANKS FOR SMALL INTERNAL PRESSURES

### F.1 Scope

**F.1.1** The maximum internal pressure for closed-top API Standard 650 tanks may be increased to the maximum internal pressure permitted when the additional requirements of this appendix are met. This appendix applies to the storage of nonrefrigerated liquids (see also API Standard 620, Appendixes Q and R). For shell temperatures above 90°C (200°F), see Appendix M.

- **F.1.2** When the internal pressure multiplied by the cross-sectional area of the nominal tank diameter does not exceed the nominal weight of the metal in the shell, roof, and any framing supported by the shell or roof, see the design requirements in F.2 through F.6. Overturning stability with respect to wind conditions shall be determined in accordance with 3.11 when specified by the purchaser. Overturning stability with respect to seismic conditions shall be determined independently of internal pressure uplift. Seismic design shall meet the requirements of Appendix E.

**F.1.3** Internal pressures that exceed the weight of the shell, roof, and framing but do not exceed 18 kPa (2<sup>1</sup>/<sub>2</sub> lbf/in.<sup>2</sup>) gauge when the shell is anchored to a counterbalancing weight, such as a concrete ringwall, are covered in F.7.

**F.1.4** Tanks designed according to this appendix shall comply with all the applicable rules of this standard unless the rules are superseded by the requirements of F.7.

**F.1.5** The tank nameplate (see Figure 8-1) shall indicate whether the tank has been designed in accordance with F.1.2 or F.1.3.

**F.1.6** Figure F-1 is provided to aid in the determination of the applicability of various sections of this appendix.

### 01 | F.2 Venting (Deleted)

### F.3 Roof Details

The details of the roof-to-shell junction shall be in accordance with Figure F-2, in which the participating area resisting the compressive force is shaded with diagonal lines.

### F.4 Maximum Design Pressure and Test Procedure

**F.4.1** The design pressure,  $P$ , for a tank that has been constructed or that has had its design details established may be calculated from the following equation (subject to the limitations of  $P_{max}$  in F.4.2):

In SI units:

$$P = \frac{(1.1)(A)(\tan \theta)}{D^2} + 0.08t_h$$

where

$P$  = internal design pressure (kPa),

$A$  = area resisting the compressive force, as illustrated in Figure F-1 (mm<sup>2</sup>),

$\theta$  = angle between the roof and a horizontal plane at the roof-to-shell junction (degrees),

$\tan \theta$  = slope of the roof, expressed as a decimal quantity,

$D$  = tank diameter (m),

$t_h$  = nominal roof thickness (mm).

In US Customary units:

$$P = \frac{(30,800)(A)(\tan \theta)}{D^2} + 8t_h$$

where

$P$  = internal design pressure (in. of water),

$A$  = area resisting the compressive force, as illustrated in Figure F-2 (in.<sup>2</sup>),

$\theta$  = angle between the roof and a horizontal plane at the roof-to-shell junction (degrees),

$\tan \theta$  = slope of the roof, expressed as a decimal quantity,

$D$  = tank diameter (ft),

$t_h$  = nominal roof thickness (in.).

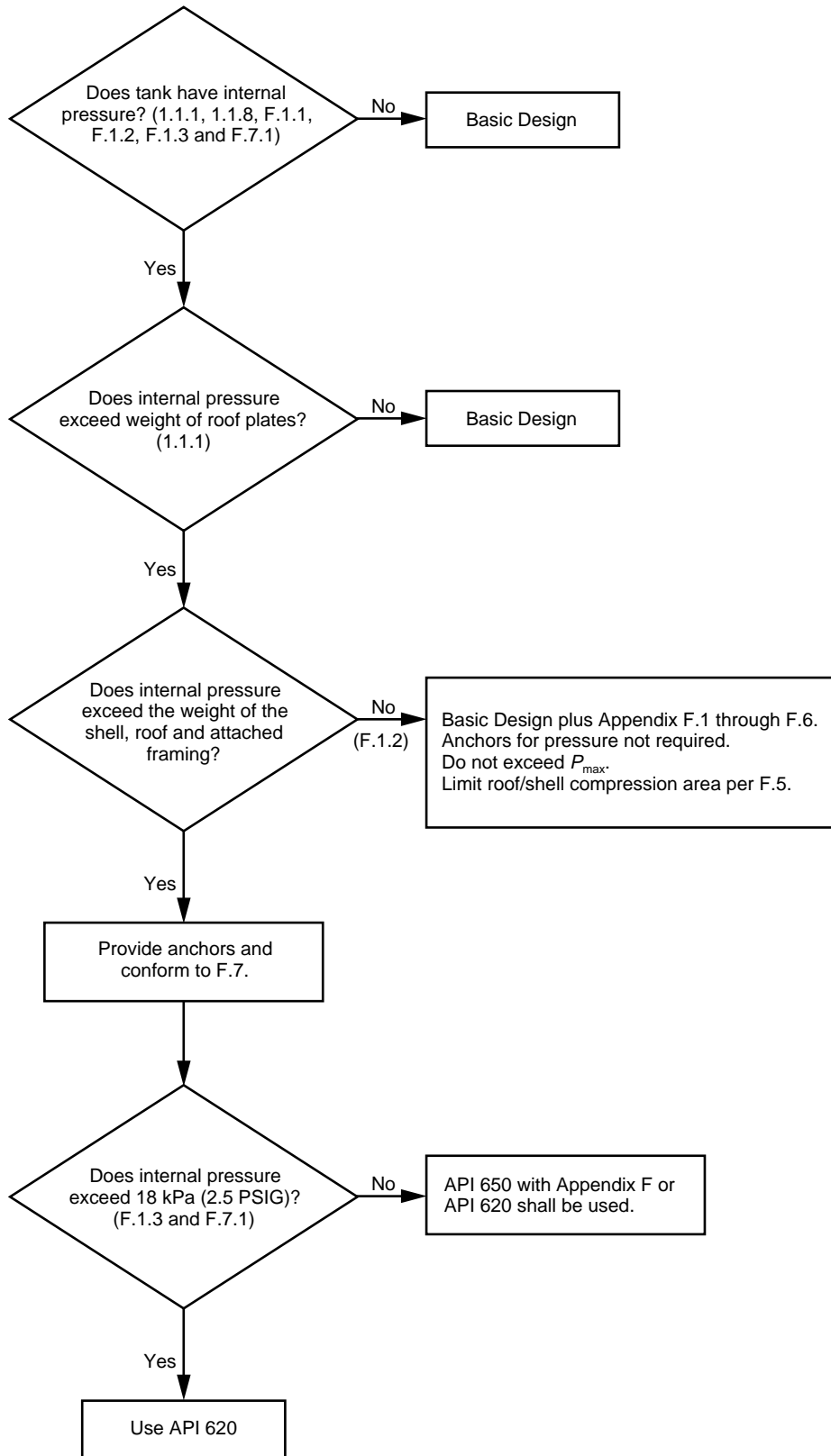
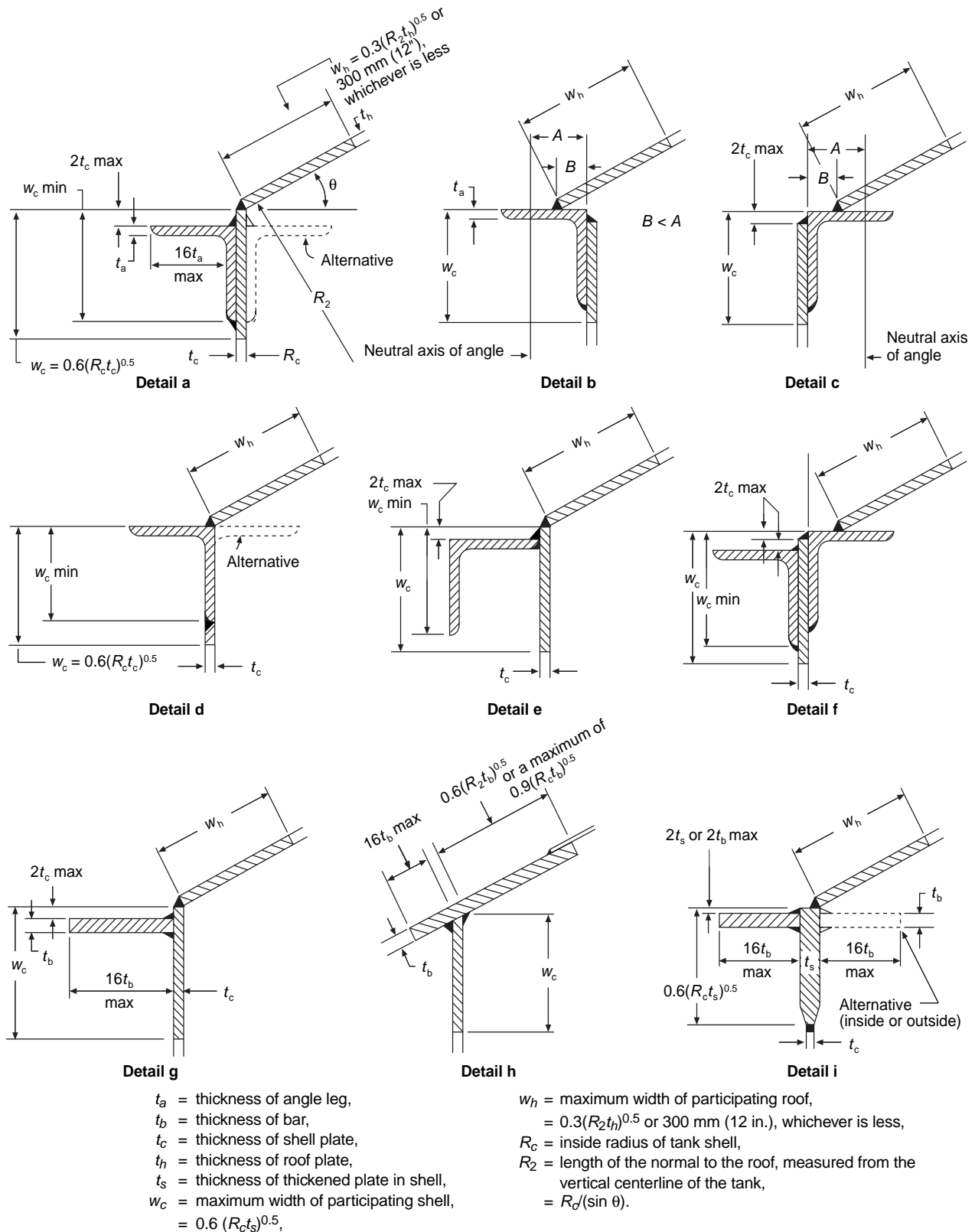

Figure F-1—Appendix F Decision Tree



Note: All dimensions and thicknesses are in mm (in.)

Figure F-2—Permissible Details of Compression Rings

**F.4.2** The maximum design pressure, limited by uplift at the base of the shell, shall not exceed the value calculated from the following equation unless further limited by F.4.3:

In SI units:

$$P_{max} = \frac{0.00127W}{D^2} + 0.08t_h - \frac{0.00382M}{D^3}$$

where

$P_{max}$  = maximum design pressure (kPa),

$W$  = total weight of the shell and any framing (but not roof plates) supported by the shell and roof (N),

$M$  = wind moment (N-m), when wind overturning stability has been specified by the purchaser in accordance with 3.11, otherwise  $M = 0$ . Anchorage may be required when the maximum design pressure is combined with the specified load. If overturning stability has not been specified, the manufacturer shall report the maximum wind velocity the tank may withstand without anchorage when combined with the maximum design pressure.

In US Customary units:

$$P_{max} = \frac{0.245W}{D^2} + 8t_h - \frac{0.735M}{D^3}$$

where

$P_{max}$  = maximum design pressure (in. of water),

$W$  = total weight of the shell and any framing (but not roof plates) supported by the shell and roof (lbf),

$M$  = wind moment (ft-lbf), when wind overturning stability has been specified by the purchaser in accordance with 3.11, otherwise  $M = 0$ . Anchorage may be required when the maximum design pressure is combined with the specified load. If overturning stability has not been specified, the manufacturer shall report the maximum wind velocity the tank may withstand without anchorage when combined with the maximum design pressure.

**F.4.3** As top angle size and roof slope decrease and tank diameter increases, the design pressure permitted by F.4.1 and F.4.2 approaches the failure pressure of F.6 for the roof-to-shell junction. In order to provide a safe margin between the maximum operating pressure and the calculated failure pressure, a suggested further limitation on the maximum design pressure for tanks with a weak roof-to-shell attachment (frangible joint) is:

$$P_{max} < 0.8P_f$$

**F.4.4** When the entire tank is completed, it shall be filled with water to the top angle or the design liquid level, and the

design internal air pressure shall be applied to the enclosed space above the water level and held for 15 minutes. The air pressure shall then be reduced to one-half the design pressure, and all welded joints above the liquid level shall be checked for leaks by means of a soap film, linseed oil, or another suitable material. Tank vents shall be tested during or after this test.

## F.5 Required Compression Area at the Roof-to-Shell Junction

**F.5.1** Where the maximum design pressure has already been established (not higher than that permitted by F.4.2 or F.4.3), the total required compression area at the roof-to-shell junction may be calculated from the following equation:

In SI units:

$$A = \frac{D^2(P - 0.08t_h)}{1.1(\tan \theta)}$$

where

$A$  = total required compression area at the roof-to-shell junction (mm<sup>2</sup>).

In US Customary units:

$$A = \frac{D^2(P - 8t_h)}{30,800(\tan \theta)}$$

where

$A$  = total required compression area at the roof-to-shell junction (in.<sup>2</sup>).

$A$  is based on the nominal material thickness less any corrosion allowance.

**F.5.2** For self-supporting roofs, the compression area shall not be less than the cross-sectional area calculated in 3.10.5 and 3.10.6.

## F.6 Calculated Failure Pressure

In tanks that meet the criteria of 3.10.2.5.1, failure can be expected to occur when the stress in the compression ring area reaches the yield point. On this basis, an approximate formula for the pressure at which failure of the top compression ring is expected to occur can be expressed in terms of the design pressure permitted by F.4.1, as follows:

In SI units:

$$P_f = 1.6P - 0.047 t_h$$

where

$P_f$  = calculated failure pressure (kPa).

In US Customary units:

$$P_f = 1.6P - 4.8 t_h$$

where

$$P_f = \text{calculated failure pressure (in. of water).}$$

Note: This formula is based on failure occurring at a yield stress 220 MPa (32,000 lbf/in.<sup>2</sup>). Experience with actual failures indicates that buckling of the roof-to-shell junction is localized and probably occurs when the yield point of the material is exceeded in the compression ring area.

## F.7 Anchored Tanks with Design Pressures up to 18 kPa (2<sup>1</sup>/<sub>2</sub> lbf/in.<sup>2</sup>) Gauge

**F.7.1** In calculating shell thickness for Appendix F tanks that are to be anchored to resist uplift due to internal pressure and when selecting shell manhole thicknesses in Table 3-3 and flush-type cleanout fitting thicknesses in Table 3-10,  $H$  shall be increased by the quantity  $P/(9.8G)$  [ $P/(12G)$ ]—where  $H$  is the design liquid height, in m (ft),  $P$  is the design pressure kPa (in. of water), and  $G$  is the design specific gravity.

**F.7.2** The required compression area at the roof-to-shell junction of a supported cone roof shall be calculated as in F.5.1, and the participating compression area at the junction shall be determined by Figure F-2. For dome roofs and self-supporting cone roofs, the required area and the participating compression area shall be in accordance with 3.12.4 of API Standard 620, except the allowable compressive stress shall be increased to 140 MPa (20,000 lbf/in.<sup>2</sup>).

**F.7.3** The design and welding of roofs and the design, reinforcement, and welding of roof manholes and nozzles shall be in accordance with API Standard 620. The thickness of a self-supporting roof shall not be less than that specified in 3.10.5 or 3.10.6, as applicable.

● **F.7.4** The design of the anchorage and its attachment to the tank shall be a matter of agreement between the manufacturer and the purchaser and shall satisfy the following conditions:

- The design stresses shall satisfy all of the conditions listed in Table F-1.
- When corrosion is a possibility, an additional thickness should be considered for anchors and attachments. If anchor bolts are used, their nominal diameter should not be less than 25 mm (1 in.) plus a corrosion allowance of at least 6 mm (<sup>1</sup>/<sub>4</sub> in.) on the diameter.
- Any anchor bolts shall be uniformly tightened to a snug fit, and any anchor straps shall be welded while the tank is filled with the test water but before any pressure is applied on top of the water. Measures, such as peening the threads or adding locking nuts, shall be taken to prevent the nuts from backing the threads.

Table F-1—Design Stresses for Anchors of Tanks with Design Pressures up to 18 kPa (2<sup>1</sup>/<sub>2</sub> lbf/in.<sup>2</sup>) Gauge

Uplift Resulting From	Allowable Stress at Root of Anchor Bolt Threads	
	MPa	(lbf/in. <sup>2</sup> )
Tank design pressure	105	15,000
Tank design pressure plus wind <sup>a</sup>	140	20,000
Tank test pressure	140	20,000
Failure pressure (from F.6) × 1.5 <sup>b</sup>	c	c

<sup>a</sup>See Appendix E for seismic design requirements.

<sup>b</sup>For this condition, the effective liquid weight on the tank bottom shall not be assumed to reduce the anchor load. The failure pressure shall be calculated using as-built thicknesses.

<sup>c</sup>Minimum specified yield strength.

d. Attachment of the anchor bolts to the shell shall be through stiffened chair-type assemblies or anchor rings of sufficient size and height. An acceptable procedure for anchor bolt chair design is given in AISI E-1, Volume II, Part VII, “Anchor Bolt Chairs.” When acceptable to the purchaser, anchor straps may be used if shell attachment is via chair-type assemblies or anchor rings of sufficient size and height.

e. Evaluate anchor attachments to the shell to ensure that localized stresses in the shell will be adequately handled. One acceptable evaluation technique is given in ASME Section VIII, Division 2, Appendix 4, using the allowable stress per API 650 substituted for  $S_m$ . The method of attachment and evaluation shall take into account the uplift conditions listed in Table F-1, and shall consider the effect of deflection and rotation of the tank shell.

f. If tanks are to be anchored, the anchors must be sized to resist the combined effects of uplift due to internal pressure and seismic loading or internal pressure and wind loading.

**F.7.5** The counterbalancing weight, such as a concrete ringwall, shall be designed so that the resistance to uplift at the bottom of the shell will be the greatest of the following:

- The uplift produced by 1.5 times the design pressure of the empty tank (minus any specified corrosion allowance) plus the uplift from the design wind velocity on the tank.
- The uplift produced by 1.25 times the test pressure applied to the empty tank (with the as-built thicknesses).
- The uplift produced by 1.5 times the calculated failure pressure ( $P_f$  in F.6) applied to the tank filled with the design liquid. The effective weight of the liquid shall be limited to the inside projection of the ringwall (Appendix-B type) from the tank shell. Friction between the soil and the ringwall may be included as resistance. When a footing is included in the ringwall design, the effective weight of the soil may be included.

**F.7.6** After the tank is filled with water, the shell and the anchorage shall be visually inspected for tightness. Air pressure of 1.25 times the design pressure shall be applied to the tank filled with water to the design liquid height. The air pressure shall be reduced to the design pressure, and the tank shall be checked for tightness. In addition, all seams above the water level shall be tested using a soap film or another mate-

rial suitable for the detection of leaks. After the test water has been emptied from the tank (and the tank is at atmospheric pressure), the anchorage shall be checked for tightness. The design air pressure shall then be applied to the tank for a final check of the anchorage.

**F.7.7 Deleted**

**| 01**

## APPENDIX G—STRUCTURALLY SUPPORTED ALUMINUM DOME ROOFS

### G.1 General

#### G.1.1 PURPOSE

This appendix establishes minimum criteria for the design, fabrication, and erection of structurally supported aluminum dome roofs. When this appendix is applicable, the requirements of 3.10 and the paragraphs in Appendix F that deal with roof design are superseded. All other requirements of API Standard 650 shall apply, except that the operating temperature shall not exceed 90°C (200°F).

#### G.1.2 DEFINITION

A structurally supported aluminum dome roof is a fully triangulated aluminum space truss with the struts joined at points arrayed on the surface of a sphere. Aluminum closure panels are firmly attached to the frame members. The roof is attached to and supported by the tank at mounting points equally spaced around the perimeter of the tank.

#### G.1.3 GENERAL APPLICATION

##### ● G.1.3.1 New Tanks

When this appendix is specified for a new tank, the tank shall be designed to support the aluminum dome roof. The roof manufacturer shall supply the magnitude and direction of all the forces acting on the tank as a result of the roof loads, together with details of the roof-to-shell attachment. The tank shall be designed as an open-top tank, and its wind girder shall meet the requirements of 3.9. The top of the tank shell shall be structurally suitable for attachment of the dome roof structure.

##### ● G.1.3.2 Existing Tanks

When this appendix is specified for an aluminum dome roof to be added to an existing tank (with or without an existing roof), the roof manufacturer shall verify that the tank has sufficient strength to support a new roof. Information on the existing tank shall be provided by the purchaser. The purchaser shall specify the existing or new appurtenances to be accommodated by the roof manufacturer. The roof manufacturer shall supply the values of the forces acting on the tank as a result of the roof loads. The purchaser shall verify the adequacy of the foundations. Unless otherwise specified, any reinforcement required to enable the tank to support the roof shall be the responsibility of the purchaser. The design and erection of the roof shall accommodate the actual tank shape. The existing tank shall be equipped with a wind girder that meets the requirements of 3.9 for an open-top tank.

##### ● G.1.3.3 Existing Tank Data Sheet

When an aluminum dome is ordered for an existing tank, a data sheet shall be completed by the purchaser (see Figure G-1).

#### G.1.4 SPECIAL FEATURES

##### ● G.1.4.1 Self-Supporting Structure

The aluminum dome roof shall be supported only from the rim of the tank; primary horizontal thrust shall be contained by an integral tension ring. The design of the connection between the roof and the tank rim shall allow for thermal expansion. A minimum temperature range of  $\pm 70^{\circ}\text{C}$  ( $120^{\circ}\text{F}$ ) shall be used for design unless a wider range is specified by the purchaser.

##### ● G.1.4.2 Finish

Unless otherwise specified, the aluminum dome roof materials shall have a mill finish.

##### ● G.1.4.3 Maintenance and Inspection

The roof manufacturer shall provide a maintenance and inspection manual for roof items that may require maintenance, periodic inspection, or both.

### G.2 Materials

#### ● G.2.1 GENERAL

Materials furnished to meet the requirements of this appendix shall be new. A complete material specification shall be submitted by the roof manufacturer for approval by the purchaser. The materials shall be compatible with the product specified to be stored in the tank and the surrounding environment. No aluminum alloy with a magnesium content greater than 3% shall be used when the design temperature of the roof exceeds  $65^{\circ}\text{C}$  ( $150^{\circ}\text{F}$ ). Properties and tolerances of aluminum alloys shall conform to *Aluminum Standards and Data*, as published by the Aluminum Association (Washington, D.C.).

#### G.2.2 STRUCTURAL FRAME

Structural frame members shall be fabricated from 6061-T6 or a recognized alloy with properties established by the Aluminum Association, Inc.

#### G.2.3 ROOF PANELS

Roof panels shall be fabricated from Series 3000 or 5000 aluminum with a minimum nominal thickness of 1.20 mm (0.050 in.).

## DATA SHEET FOR A STRUCTURALLY SUPPORTED ALUMINUM DOME ADDED TO AN EXISTING TANK

JOB NO. \_\_\_\_\_ ITEM NO. \_\_\_\_\_  
 PURCHASE ORDER NO. \_\_\_\_\_  
 REQUISITION NO. \_\_\_\_\_  
 INQUIRY NO. \_\_\_\_\_  
 PAGE 1 OF 1 BY \_\_\_\_\_

(INFORMATION TO BE COMPLETED BY THE PURCHASER)

1. PURCHASER/AGENT \_\_\_\_\_  
 ADDRESS \_\_\_\_\_  
 CITY \_\_\_\_\_ STATE \_\_\_\_\_ ZIP \_\_\_\_\_  
 PHONE \_\_\_\_\_ FAX \_\_\_\_\_
2. USER \_\_\_\_\_
3. ERECTION SITE: NAME OF PLANT \_\_\_\_\_  
 LOCATION \_\_\_\_\_
4. TANK NO. \_\_\_\_\_
5. PUMPING RATES: IN \_\_\_\_\_ m<sup>3</sup>/h (bbl/h)      OUT \_\_\_\_\_ m<sup>3</sup>/h (bbl/h)
6. MAXIMUM DESIGN ROOF TEMPERATURE \_\_\_\_\_ [NOT TO EXCEED 90°C (200°F)]
7. DESIGN PRESSURE:  ATMOSPHERIC OR \_\_\_\_\_ kPa (in.) OF WATER (INDICATE WHETHER POSITIVE OR NEGATIVE)
8. ROOF LOADS: UNIFORM LIVE \_\_\_\_\_ kPa (lb/ft<sup>2</sup>)  
 SPECIAL (PROVIDE SKETCH) \_\_\_\_\_ kPa (lb/ft<sup>2</sup>)
9. EARTHQUAKE DESIGN:  YES  NO  
 SEISMIC ZONE \_\_\_\_\_  
 ZONE FACTOR (SEE TABLE E-2) \_\_\_\_\_  
 IMPORTANT FACTOR \_\_\_\_\_  
 SNOW LOAD, IF ANY, TO BE COMBINED WITH SEISMIC \_\_\_\_\_ kPa (lb/ft<sup>2</sup>)
10. WIND LOAD: VELOCITY \_\_\_\_\_ Km/h (mph)
11. MAXIMUM HEIGHT FROM TOP OF SHELL TO TOP OF DOME \_\_\_\_\_ m (ft)

12. TANK SHELL THICKNESS (ACTUAL)

COURSE NUMBER	MINIMUM THICKNESS	TYPICAL THICKNESS	PLATE WIDTH
_____	_____	_____	_____
_____	_____	_____	_____
_____	_____	_____	_____
_____	_____	_____	_____
_____	_____	_____	_____
_____	_____	_____	_____

13. ACTUAL TANK STIFFENER DETAILS, POSITION AND DIMENSIONS (PROVIDE SKETCH)
14. GASES EXPECTED IN THE VAPOR SPACE \_\_\_\_\_
15. REQUIRED FREEBOARD ABOVE TOP OF TANK \_\_\_\_\_ mm (in.)
16. ACTUAL MINIMUM TANK DIAMETER AT THE TOP OF THE TANK \_\_\_\_\_ m (ft)  
 ACTUAL MAXIMUM TANK DIAMETER AT THE TOP OF THE TANK \_\_\_\_\_ m (ft)
17. ELEVATION OF TOP OF TANK: MAXIMUM \_\_\_\_\_ MINIMUM \_\_\_\_\_
18. LIST ALL APPURTENANCES, OTHER THAN THOSE TO BE REMOVED BY THE PURCHASER, AND INDICATE ACTION REQUIRED OF CONTRACTOR

APPURTENANCE	CONTRACTOR ACTION	
	REMOVE	ACCOMMODATE
_____	<input type="radio"/>	<input type="radio"/>
_____	<input type="radio"/>	<input type="radio"/>
_____	<input type="radio"/>	<input type="radio"/>
_____	<input type="radio"/>	<input type="radio"/>
_____	<input type="radio"/>	<input type="radio"/>
_____	<input type="radio"/>	<input type="radio"/>
_____	<input type="radio"/>	<input type="radio"/>
_____	<input type="radio"/>	<input type="radio"/>

Figure G-1—Data Sheet for a Structurally Supported Aluminum Dome Added to an Existing Tank

**G.2.4 BOLTS AND FASTENERS**

Fasteners shall be of 7075-T73 aluminum, 2024-T4 aluminum, austenitic stainless steel, or other materials as agreed to by the purchaser. Only stainless steel fasteners shall be used to attach aluminum to steel.

**G.2.5 SEALANT AND GASKET MATERIAL**

**G.2.5.1** Sealants shall be silicone or urea urethane compounds that conform to Federal Spec TT-S-00230C unless another material is required for compatibility with stored materials. Sealants shall remain flexible over a temperature range of -60°C to +150°C (-80°F to +300°F) without tearing, cracking, or becoming brittle. Elongation, tensile strength, hardness, and adhesion shall not change significantly with aging or exposure to ozone, ultraviolet light, or vapors from the product stored in the tank.

**G.2.5.2** Preformed gasket material shall be Neoprene, silicone, Buna-N, urea urethane, or EPDM elastomer meeting ASTM C 509 or Federal Spec ZZ-R-765C unless another material is required for compatibility with stored materials.

**G.2.6 SKYLIGHT PANELS**

Skylight panels shall be clear acrylic or polycarbonate with a minimum nominal thickness of 6 mm (0.25 in.).

**G.3 Allowable Stresses**

**G.3.1 ALUMINUM STRUCTURAL MEMBERS**

Aluminum structural members and connections shall be designed in accordance with the *Aluminum Design Manual*, as published by the Aluminum Association, Inc. (Washington, D.C.), except as modified by this appendix.

**G.3.2 ALUMINUM PANELS**

Aluminum panels shall be designed in accordance with *Specifications for Aluminum Sheet Metal Work in Building Construction*, as published by the Aluminum Association, Inc. (Washington, D.C.) and this appendix. Attachment fasteners shall not penetrate both the panel and the flange of the structural member.

**G.3.3 BOLTS AND FASTENERS**

**G.3.3.1** The maximum stress in bolts and fasteners for any design condition shall not exceed the allowable stress given in Table G-1.

**G.3.3.2** The hole diameter for a fastener shall not exceed the diameter of the fastener plus 1.5 mm (1/16 in.).

Table G-1—Bolts and Fasteners

Materials	Allowable Tensile Stress <sup>a,b</sup>		Allowable Shear Stress <sup>a,b,c</sup>	
	(MPa)	(ksi)	(MPa)	(ksi)
Austenitic stainless steel <sup>d</sup>	172	25.0	124	18.0
Austenitic stainless steel <sup>e</sup>	234	34.0	172	25.0
2024-T4 aluminum	182	26.0	109	16.0
7075-T73 aluminum	201	28.0	120	17.0

<sup>a</sup>The root-of-thread area shall be used to calculate the strength of threaded parts.  
<sup>b</sup>For wind and seismic loads, these values may be increased by one-third.  
<sup>c</sup>If the thread area is completely out of the shear area, the cross-sectional area of the shank may be used to determine the allowable shear load.  
<sup>d</sup>For bolts with a minimum tensile strength of 620 MPa (90 ksi).  
<sup>e</sup>For bolts with a minimum tensile strength of 860 MPa (125 ksi).  
<sup>f</sup>For fasteners not shown above, design shall be in accordance with the *Aluminum Design Manual*, as published by the Aluminum Association, Inc. (Washington, D.C.).

**G.4 Design**

**G.4.1 DESIGN PRINCIPLES**

**G.4.1.1** The roof framing system shall be designed as a three-dimensional space frame or truss with membrane covering (roof panels) providing loads along the length of the individual members. The design must consider the increased compression induced in the framing members due to the tension in the roof panels.

**G.4.1.2** The actual stresses in the framing members and panels under all design load conditions shall be less than or equal to the allowable stresses per the *Aluminum Design Manual*, as published by the Aluminum Association, Inc. (Washington, D.C.).

**G.4.1.3** Local and general buckling of the dome roof must be considered with a minimum factor of safety of 1.65 applied to the buckling equation or method. General buckling of the dome roof shall be considered either by using non-linear finite element analysis or the following equation:

In SI units:

$$W_a = \frac{108.1 \times 10^6 \sqrt{I_x A_g}}{(SF)LR^2}$$

where

- $W_a$  = allowable total dead load, plus live load in kPa,
- $I_x$  = moment of inertia of frame members against bending in a plane normal to the dome surface in cm<sup>4</sup>,
- $A_g$  = cross sectional area of beam in cm<sup>2</sup>,
- $R$  = spherical radius of the dome in cm,
- $L$  = average dome beam length in cm,
- $SF$  = safety factor (1.65).

In US Customary units:

$$W_a = \frac{2258 \times 10\% \sqrt{I_x A_g}}{(SF)LR^2}$$

where

- $W_a$  = allowable total dead load, plus live load (lbf/ft<sup>2</sup>),
- $I_x$  = moment of inertia of frame members against bending in a plane normal to the dome surface (in.<sup>4</sup>),
- $A_g$  = cross sectional area of beam (in.<sup>2</sup>),
- $R$  = spherical radius of the dome (in.),
- $L$  = average dome beam length (in.),
- $SF$  = safety factor (1.65).

**G.4.1.4** The minimum net tension ring area (exclusive of bolt holes and member top flange protrusions) shall be determined per the following formula:

In SI units:

$$A_n = \frac{5.27D^2}{\eta \tan \theta \sin\left(\frac{180}{\eta}\right) F_t}$$

where

- $A_n$  = net area of tension beam, in cm<sup>2</sup>,
- $D$  = nominal tank diameter, in m,
- $\eta$  = number of dome supports,
- $\theta$  =  $1/2$  the central angle of the dome or roof slope at the tank shell,
- $F_t$  = allowable stress of the tension ring, in kPa.

In US Customary units:

$$A_n = \frac{11D^2}{\eta \tan \theta \sin\left(\frac{180}{\eta}\right) F_t}$$

where

- $A_n$  = net area of tension beam (in.<sup>2</sup>),
- $D$  = nominal tank diameter (ft),
- $\eta$  = number of dome supports,
- $\theta$  =  $1/2$  the central angle of the dome or roof slope at the tank shell,
- $F_t$  = allowable stress of the tension ring (lbf/in.<sup>2</sup>).

In cases where the total dead load plus live load is greater than 1.34 kPa (28 lb/ft<sup>2</sup>), the above formula shall be multiplied by the factor  $W/1.34$  (or 28), where  $W$  = the total dead load plus live load for the dome.

Note: This formula does not include factors for bending stresses due to loads from the panel attached to the beam. These stresses must also be considered in the tension ring design, as per G.3.1.

## G.4.2 DESIGN LOADS

### G.4.2.1 Dead Load

The dead load shall be the weight of the roof and all accessories permanently attached to it, including any insulation.

### G.4.2.2 Live Load

#### ● G.4.2.2.1 Uniform Live Load

The minimum live load shall be a uniform load of 1.2 kPa (25 lbf/ft<sup>2</sup>) of projected area.

#### G.4.2.2.2 Unbalanced Live Load

The design shall consider one-half of the uniform load required per square foot applied to one-half of the dome with no live load on the other half.

### G.4.2.3 Wind Load

- **G.4.2.3.1** For dome structural design, the minimum wind load shall be the load resulting from a design wind velocity of 160 km/h (100 mph) which imposes a dynamic pressure of 1.48 kPa (31 lbf/ft<sup>2</sup>), unless a different wind loading is specified by the purchaser. The following pressure coefficients shall be used: 100

- a. Windward quarter = -0.9.
- b. Center half = -0.7.
- c. Leeward quarter = -0.5.

For domes designed for wind velocities other than 160 km/h (100 mph), the wind load shall be adjusted per the following:

In SI units:

$$(V/160)^2$$

In US Customary units:

$$(V/100)^2$$

where

- $V$  = wind velocity in km/h (mph), as specified by the purchaser. 100

Note: The reference velocity pressure of 1.48 kPa (31 lbf/ft<sup>2</sup>) is based on ASCE 7-93, "Category IV, Exposure C, with an Importance Factor of 0.95." 100

- **G.4.2.3.2** See 3.11 for tank overturning stability, when specified by the purchaser.

#### G.4.2.4 Seismic Load

If the tank is designed for seismic loads, the roof shall be designed for a horizontal seismic force determined as follows:

$$F = 0.6 ZIW_r$$

where

$F$  = horizontal seismic force.

$Z$ ,  $I$ , and  $W_r$  are as defined in Appendix E. The force shall be uniformly applied over the surface of the roof.

#### ● G.4.2.5 Load Combinations

The following load combinations shall be considered:

- a. Dead load.
- b. Dead load plus uniform live load.
- c. Dead load plus unbalanced live load.
- d. Dead load plus wind load.
- e. Dead load plus uniform live load plus wind load.
- f. Dead load plus unbalanced live load plus wind load.
- g. Dead load plus seismic load.

If an internal or external design pressure is specified by the purchaser, the loads resulting from either of these pressures shall be added to the load combinations specified in Items a–g above, and the structure shall be designed for the most severe loading.

#### G.4.2.6 Panel Loads

**G.4.2.6.1** Roof panels shall be of one-piece aluminum sheet (except for skylights as allowed by G.8.4) and shall be designed to support a uniform load of 3 kPa (60 lbf/ft<sup>2</sup>) over the full area of the panel without sustaining permanent distortion.

**G.4.2.6.2** The roof shall be designed to support two concentrated loads 1100 N (250 lbf), each distributed over two separate 0.1 m<sup>2</sup> (1 ft<sup>2</sup>) areas of any panel.

**G.4.2.6.3** The loads specified in G.4.2.6.1 and G.4.2.6.2 shall not be considered to act simultaneously or in combination with any other loads.

#### ● G.4.3 INTERNAL PRESSURE

Unless otherwise specified by the purchaser, the internal design pressure shall not exceed the weight of the roof. In no case shall the maximum design pressure exceed 2.2 kPa (9 in.) water column. When the design pressure,  $P_{max}$ , for a tank with an aluminum dome roof is being calculated, the weight of the roof, including structure, shall be added to the weight of the shell in the  $W$  term in F.4.2, and  $t_h$  shall be

01 | taken as zero.

## G.5 Roof Attachment

### G.5.1 LOAD TRANSFER

Structural supports for the roof shall be bolted or welded to the tank. To preclude overloading of the shell, the number of attachment points shall be determined by the roof manufacturer in consultation with the tank manufacturer. The attachment detail shall be suitable to transfer all roof loads to the tank shell and keep local stresses within allowable limits.

### G.5.2 ROOF SUPPORTS

The roof attachment points may incorporate a slide bearing with low-friction bearing pads to minimize the horizontal radial forces transferred to the tank. As an alternative, the roof may be attached directly to the tank, and the top of the tank analyzed and designed to sustain the horizontal thrust transferred from the roof, including that from differential thermal expansion and contraction.

#### ● G.5.3 SEPARATION OF CARBON STEEL AND ALUMINUM

Unless another method is specified by the purchaser, aluminum shall be isolated from carbon steel by an austenitic stainless steel spacer or an elastomeric isolator bearing pad.

### G.5.4 ELECTRICAL GROUNDING

The aluminum dome roof shall be electrically interconnected with and bonded to the steel tank shell or rim. As a minimum, stainless steel cable conductors 3 mm (<sup>1</sup>/<sub>8</sub> in.) in diameter shall be installed at every third support point. The choice of cable shall take into account strength, corrosion resistance, conductivity, joint reliability, flexibility, and service life.

## G.6 Physical Characteristics

### G.6.1 SIZES

An aluminum dome roof may be used on any size tank erected in accordance with this standard.

#### ● G.6.2 DOME RADIUS

The maximum dome radius shall be 1.2 times the diameter of the tank. The minimum dome radius shall be 0.7 times the diameter of the tank unless otherwise specified by the purchaser.

#### ● G.7 Platforms, Walkways, and Handrails

Platforms, walkways, and handrails shall conform to 3.8.10 except that the maximum concentrated load on walkways or stairways supported by the roof structure be 4450 N (1000 lbf). When walkways are specified to go across the exterior of the

roof (to the apex, for example), stairways shall be provided on portions of walkways whose slope is greater than 20 degrees. Walkways and stairways may be curved or straight segments.

## G.8 Appurtenances

### ● G.8.1 ROOF HATCHES

If roof hatches are required, each hatch shall be furnished with a curb 100 mm (4 in.) or higher and a positive latching device to hold the hatch in the open position. The minimum size of opening shall not be less than 600 mm (24 in.). The axis of the opening may be perpendicular to the slope of the roof, but the minimum clearance projected on a horizontal plane shall be 500 mm (20 in.).

### G.8.2 ROOF NOZZLES AND GAUGE HATCHES

Roof nozzles and gauge hatches shall be flanged at the base and bolted to the roof panels with an aluminum reinforcing plate on the underside of the panels. The axis of a nozzle or gauge hatch shall be vertical. If the nozzle is used for venting purposes, it shall not project below the underside of the roof

panel. Aluminum or stainless steel flanges may be bolted directly to the roof panel, with the joint caulked with sealant. Steel flanges shall be separated from the aluminum panel by a gasket (see Figure G-2 for a typical nozzle detail).

### G.8.3 ROOF VENTS (Section replaced by 3.10.8)

01

### ● G.8.4 SKYLIGHTS

**G.8.4.1** If skylights are specified by the purchaser, each skylight shall be furnished with a curb 100 mm (4 in.) or higher and shall be designed for the live and wind loads specified in G.4.2.6. The purchaser shall specify the total skylight area to be provided.

01

**G.8.4.2** When skylights are specified for tanks without floating roofs or for floating roof tanks which are sealed and gas blanketed (not provided with circulation venting per H.5.2.2.1 & H.5.2.2.2), the purchaser shall consider skylight material compatibility with exposure to elevated concentrations of the stored product.

01

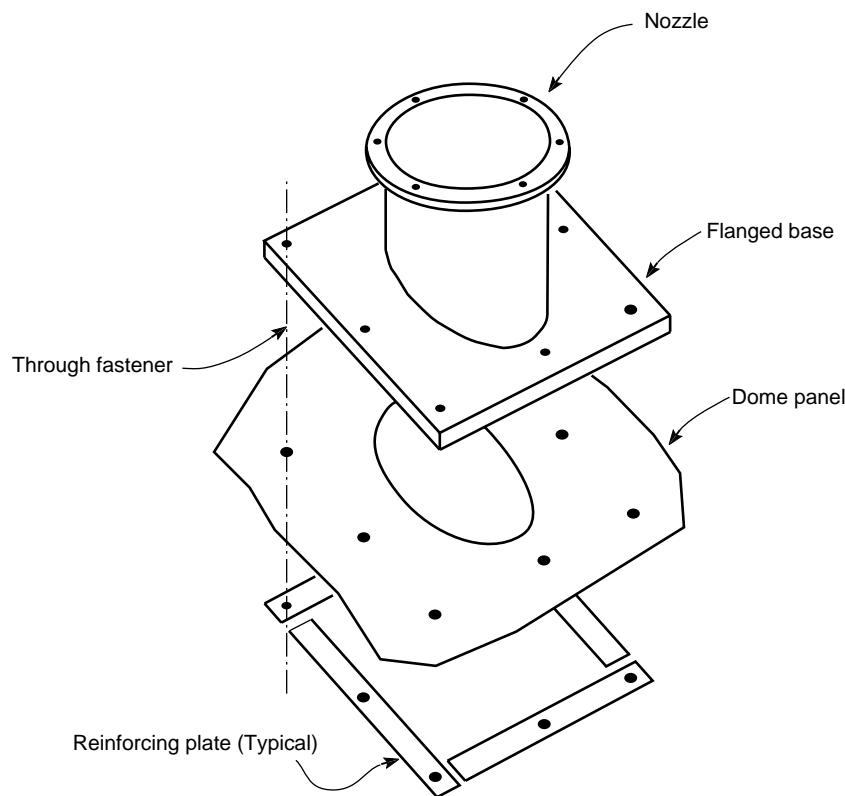

Figure G-2—Typical Roof Nozzle

## ● G.9 Sealing at the Shell

The roof need not be sealed to the tank shell unless specified by the purchaser or required to contain internal pressure. The bottom of the flashing shall extend at least 50 mm (2 in.) below the top of the tank. Corrosion-resistant coarse-mesh screen [13 mm ( $1/2$  in.) openings] shall be provided to prevent the entrance of birds.

## G.10 Testing

### G.10.1 LEAK TESTING

- **G.10.1.1** After completion, the roof seams shall be leak tested by spraying the outside of the seams with water from a hose with a minimum static head pressure 350 kPa (50 lbf/in.<sup>2</sup>) gauge at the nozzle. Because of possible corrosive effects, consideration shall be given to the quality of the water used and the duration of the test. Potable water shall be used unless otherwise specified. The water shall not be sprayed directly on roof vents. Any water on the inside of the roof shall constitute evidence of leakage.

- **G.10.1.2** Where gastight roofs are required, leak testing may be accomplished in accordance with F.4.4 or F.7.6 or by another means acceptable to the roof manufacturer and the purchaser.

**G.10.1.3** Any leaks discovered during testing shall be sealed, and the roof shall be retested until all leaks are sealed.

## G.11 Fabrication and Erection

### G.11.1 GENERAL

The dome contractor shall perform the work described in this appendix using qualified supervisors who are skilled and experienced in the fabrication and erection of aluminum structures.

### G.11.2 FABRICATION

All roof parts shall be prefabricated for field assembly. Fabrication procedures shall be in accordance with Section 6

of AA AS-GSD-516169 All structural shapes used to make the roof shall be punched or drilled before any shop coating is applied. **100**

### ● G.11.3 WELDING

The design and fabrication of welded aluminum parts shall be in accordance with the *Aluminum Design Manual: Specifications for Aluminum Structures* and AWS D1.2. All aluminum structural welds and components joined by welding shall be visually inspected and tested by dye-penetrant examination in accordance with Section 6, Part D, of AWS D1.2. All structural welding of aluminum shall be performed before the dome is erected in the field. A full set of satisfactory examination records shall be delivered to the owner before field erection.

### G.11.4 SHIPPING AND HANDLING

Materials shall be handled, shipped, and stored in a manner that does not damage the surface of aluminum or the surface coating of steel.

### G.11.5 ERECTION

The erection supervisor shall be experienced in the construction of aluminum dome roofs and shall follow the manufacturer's instructions and drawings furnished for that purpose.

### G.11.6 WORKMANSHIP

To minimize internal stresses on the structure when fasteners are tightened, the roof shall be installed on supports that are in good horizontal alignment. The components of the structure shall be erected with precise fit and alignment. Field cutting and trimming, relocation of holes, or the application of force to the parts to achieve fit-up is not acceptable.



## APPENDIX H—INTERNAL FLOATING ROOFS

### ● H.1 Scope

This appendix provides minimum requirements that apply to a tank with an internal floating roof and a fixed roof at the top of the tank shell, and to the tank appurtenances. This appendix is intended to limit only those factors that affect the safety and durability of the installation and that are considered to be consistent with the quality and safety requirements of this standard. Types of internal floating roofs (listed under H.2) and materials (listed under H.3) are provided as a basic guide and shall not be considered to restrict the purchaser option of employing other commonly accepted or alternative designs, as long as all design loading is documented to meet the minimum requirements herein, and all other criteria are met (except alternative materials and thicknesses as permitted by H.3.1). The requirements apply to the internal floating roof of a new tank and may be applied to an existing fixed-roof tank. Section 3.10 of this standard is applicable, except as modified in this appendix.

### H.2 Types

- 01 ● **H.2.1** The internal floating roof type shall be selected by the purchaser after consideration of both proposed and future product service, operating conditions, maintenance requirements, regulatory compliance, service life expectancy, ambient temperature, design temperature, product vapor pressure, corrosion conditions and other compatibility factors. Other operating conditions requiring consideration include (but are not limited to) anticipated pumping rates, roof landing cycles, and the potential for turbulence resulting from upsets, such as vapor slugs injected into the tank. Safety and risk factors associated with the roof types shall also be evaluated.<sup>1</sup>

**H.2.2** The following types of internal floating roofs are described in this appendix:

- a. Metallic pan internal floating roofs<sup>2,3</sup> have a peripheral rim above the liquid for buoyancy. These roofs are in full contact with the liquid surface and are typically constructed of steel.
- b. Metallic open top bulk-headed internal floating roofs<sup>3</sup> have peripheral open-top bulk-headed compartments for

<sup>1</sup>Internal floating roof tanks generally have reduced fire risk, and the use of fixed fire suppression systems is often not mandatory. Various internal floating roof materials will have unique flammability characteristics, melting points and weights (perhaps with reduced buoyancy being required). If fire suppression systems are used, certain roof types need to be evaluated for full surface protection. NFPA 11 can provide guidance for this evaluation.

<sup>2</sup>The Purchaser should note that this design does not have multiple flotation compartments necessary to meet the requirements of H.4.2.4.

buoyancy. Distributed open-top bulk-headed compartments shall be used as required. These roofs are in full contact with the liquid surface and are typically constructed of steel.

c. Metallic pontoon internal floating roofs have peripheral closed-top bulk-headed compartments for buoyancy. Distributed closed-top bulk-headed compartments shall be used as required. These roofs are in full contact with the liquid surface and are typically constructed of steel.

d. Metallic double-deck internal floating roofs have continuous closed top and bottom decks which contain bulk-headed compartments for buoyancy. These roofs are in full contact with the liquid surface and are typically constructed of steel.

e. Metallic internal floating roofs on floats have their deck above the liquid, supported by closed pontoon compartments for buoyancy. These roof decks are not in full contact with the liquid surface and are typically constructed of aluminum alloys or stainless steel.

f. Metallic sandwich-panel internal floating roofs have metallic panel modules for buoyancy compartments. Panel modules may include a honeycomb core; however, cell walls within the panel module are not considered “compartments” for purposes of inspection and design buoyancy requirements (see H.4.1.7 and H.4.2.4)<sup>4</sup>. These roofs are in full contact with the liquid surface and are typically constructed of aluminum alloys.

g. Hybrid internal floating roofs shall, upon agreement between the purchaser and the manufacturer, be a design combination of roof types described in H.2.2.b and H.2.2.c, having bulkhead compartments with closed-top perimeter pontoon and open-top center compartments for buoyancy. These roofs are in full contact with the liquid surface and are typically constructed of steel.

### H.3 Material

- 01 ● **H.3.1** Internal floating roof materials shall be selected by the purchaser after consideration of items listed under H.2.1. The manufacturer shall submit a complete material

<sup>3</sup>These designs contain no closed buoyancy compartments, and are subject to flooding during sloshing or during application of fire fighting foam/water solution. Also, without bracing of the rim being provided by the pontoon top plate, design to resist buckling of the rim must be evaluated. These types are considered a fixed roof tank (i.e., having no internal floating roof) for the siting requirements of NFPA 30.

<sup>4</sup>A single inspection opening per panel module is permitted, regardless of core material; however, core materials producing enclosed spaces within a module may result in undetectable combustible gas in areas isolated from the inspection opening. Design buoyancy shall be based on the loss of any two full panel modules (not cells within modules).

specification in his proposal. The choice of materials should be governed by compatibility with the specified liquid. Material produced to specifications other than those listed in this appendix (alternative materials) may be used. Material shall be certified to meet all the requirements of a material specification listed in this appendix, and approved by the purchaser or shall comply with requirements as specified by the purchaser. When specified by the purchaser, a corrosion allowance shall be added to the minimum nominal thickness indicated below. The “nominal thickness” is the purchased thickness with allowance for the permissible mill tolerance.

### H.3.2 STEEL

Steel shall conform to the requirements of Section 2 of this standard. Steel in contact with vapor or liquid shall be 5 mm ( $\frac{3}{16}$  in.) minimum nominal thickness. Other steel shall be 2.5 mm (0.094 in.) minimum nominal thickness.

### H.3.3 ALUMINUM

Aluminum shall conform to the requirements of Section 2 of ASME B96.1. Aluminum skin shall be 0.51 mm (0.020 in.) minimum nominal thickness. Aluminum floats shall be 1.3 mm (0.050 in.) minimum nominal thickness. For a sandwich panel flotation unit, core material shall be at least 25 mm (1.0 in.) thick, and metallic skin (except carbon steel) shall be 0.41 mm (0.016 in.) minimum nominal thickness.

### H.3.4 STAINLESS STEEL

Stainless steel shall conform to the requirements of ASTM A 240/A 240M (austenitic type only). Stainless steel skin shall be 0.46 mm (0.018 in.) minimum nominal thickness. Stainless steel floats shall be 1.2 mm (0.048 in.) minimum nominal thickness.

## H.4 Requirements for All Types

### H.4.1 GENERAL

**H.4.1.1** An internal floating roof and its accessories shall be designed and constructed to allow the roof to operate throughout its normal travel without manual attention and without damage to any part of the fixed roof, the internal floating roof, internal floating roof seals (except for normal wear), the tank, or their appurtenances. The internal floating roof and seals shall be designed to operate in a tank constructed within the dimensional limits defined in Section 5.5 of this standard.

**H.4.1.2** The internal floating roof shall be designed and built to float and rest in a uniform horizontal plane (no drainage slope required).

**H.4.1.3** All seams in the internal floating roof that are exposed to product vapor or liquid shall be vapor tight in accordance with H.4.3.1.

**H.4.1.4** A vapor tight rim (or skirt), extending at least 150 mm (6 in.) above the liquid at the design flotation level, shall be provided around both the internal floating roof periphery and around all internal floating roof penetrations (columns, ladders, stilling wells, manways, open deck drains and other roof openings).

**H.4.1.5** The non-contact type (H.2.2.e) internal floating roof shall have a vapor-tight rim (or skirt), extending at least 100 mm (4 in.) into the liquid at the design flotation level, around both the internal floating roof periphery and around all internal floating roof penetrations (columns, ladders, stilling wells, manways, open deck drains and other roof openings), with the exception of penetrations for pressure-vacuum (bleeder) vents (per H.5.2.1).

- **H.4.1.6** All conductive parts of the internal floating roof shall be electrically interconnected and bonded to the outer tank structure. This may be accomplished by electric bonding shunts in the seal area (a minimum of four, uniformly distributed) or flexible cables from the external tank roof to the internal floating roof (a minimum of two, uniformly distributed). The choice of bonding devices shall be specified by the purchaser, considering strength, corrosion resistance, joint reliability, flexibility, and service life.

**H.4.1.7** Each compartment shall be capable of being field-inspected for the presence of combustible gas. Inspection openings shall be located above the liquid level and closed compartments shall be capable of being resealed in the field after periodic inspection (to prevent liquid or vapor entry). Closed-top compartments (types H.2.2.c, d, and g) shall be accessible from the top of the internal floating roof and provided with a secured and gasketed manhole for visual internal inspection and the manhole cover shall be provided with a suitable vent. The top edge of the manhole shall extend a minimum of 25mm (1 in.) above the top of the pontoon rim/skirt.

- **H.4.1.8** All closed flotation compartments shall be seal welded to prevent liquid or vapor entry, unless otherwise specified by the purchaser. For pontoon, double-deck and hybrid internal floating roofs (types H.2.2.c, d, and g), included with seal welding the flotation compartment, the top edge of each bulkhead shall also be provided with a continuous seal weld so that the top edge is liquid and vapor tight.

**H.4.1.9** For metallic sandwich-panel roofs (type H.2.2.f), if the use of adhesives is allowed by the purchaser (per H.4.3.4) to seal the flotation panels (in lieu of welding), all exposed adhesives shall be compatible with the product service and flotation test water (purchaser shall consider future product

service, the hydrostatic test condition, and design condition changes to specify adhesive compatibility).

- **H.4.1.10** When specified by the purchaser for deck surfaces above the liquid level, deck drains shall be provided to return any spillage or condensate to the product. Such drains shall close automatically or extend at least 100 mm (4 in.) into the product to minimize vapor loss.

**H.4.1.11** Internal floating roofs classified as full contact types (see H.2.2) shall be designed to minimize trapped vapor space beneath the internal floating roof.

## H.4.2 INTERNAL FLOATING ROOF DESIGN

**H.4.2.1** All internal floating roof design calculations shall be based on the lower of the product specific gravity or 0.7 (to allow for operation in a range of hydrocarbon service), regardless of any higher specific gravity that might be specified by the purchaser.

- **H.4.2.2** The internal floating roof shall be designed to safely support at least two men (2.2 kN [500 lbf] over 0.1 m<sup>2</sup> [1 ft<sup>2</sup>]) walking anywhere on the roof while it is floating or resting on its supports without damaging the floating roof and without allowing product on the roof. If specified by the purchaser, the concentrated load design criteria may be modified for roofs less than 9 m (30 ft.) diameter (where internal floating roofs may become unstable), to account for access needs, and expected concentrated live loads.

**H.4.2.3** All internal floating roofs shall include buoyancy required to support at least twice its dead weight (including the weight of the flotation compartments, seal and all other floating roof and attached components), plus additional buoyancy to offset the calculated friction exerted by peripheral and penetration seals during filling.

**H.4.2.4** All internal floating roofs with multiple flotation compartments shall be capable of floating without additional damage after any two compartments are punctured and flooded. Designs which employ an open center deck in contact with the liquid (types H.2.2.b, c, and g) shall be capable of floating without additional damage after any two compartments and the center deck are punctured and flooded.

- **H.4.2.5** Internal floating roof supports and deck structural attachments (such as reinforcing pads and pontoon end gussets) shall be designed to support the full dead load of the internal floating roof (including all components, such as seals and accessories) plus a uniform live load of 0.6 kPa (12.5 lbf/ft<sup>2</sup>) over the internal floating roof deck surface while the internal floating roof is resting on its supports. This uniform live load may be reduced to 0.24 kPa (5 lbf/ft<sup>2</sup>) if the floating roof is equipped with operable drains or other means of automatically preventing an accumulation of liquid. Consideration shall also be made for non-uniform support settlement/

load distribution, based on anticipated conditions specified by the purchaser.

- **H.4.2.6** Calculations for both the floating and supported condition, considering internal floating roof deflections and stresses for each of the load conditions required by this appendix, shall be performed and reported to the purchaser, when specified. All calculations for the floating condition shall be based upon the design specific gravity (per H.4.2.1).

**H.4.2.7** The manufacturer shall specify the internal floating roof weight and total flotation displacement provided based on a flotation level for design specific gravity per H.4.2.1.

**H.4.2.8** Aluminum load carrying members, assemblies and connections shall comply with the design requirements of the latest edition of the “Aluminum Design Manual: Specification for Aluminum Structures,” as published by the Aluminum Association, Inc. (Washington, DC).

- **H.4.2.9** Steel structural components shall be proportioned so that the maximum stresses shall not exceed the limitations specified in the latest edition of the “Manual of Steel Construction, Allowable Stress Design,” as published by the American Institute of Steel Construction (Chicago, IL). For other steel components, the allowable stress and stability requirements shall be jointly established by the purchaser and the manufacturer, as part of the inquiry. Alternatively, a proof test (simulating the conditions of H.4.2) may be performed on the roof or on one of similar design.

## H.4.3 JOINT DESIGN

- **H.4.3.1** All seams in the floating roof exposed directly to product vapor or liquid shall be welded, bolted, screwed, riveted, clamped, or sealed and checked for vapor tightness per H.6.2.

**H.4.3.2** Welded joints between stainless steel members and welded joints between carbon steel members shall conform to Section 3.1 of this standard. Welded joints between aluminum members shall conform to Section 3.1 of ASME B96.1.

**H.4.3.2.1** Single-welded butt joints without backing are acceptable for flotation units where one side is inaccessible.

**H.4.3.2.2** Fillet welds on material less than 5 mm (<sup>3</sup>/<sub>16</sub> in.) thick shall not have a thickness less than that of the thinner member of the joint.

- **H.4.3.3** Bolted, threaded, and riveted joints are acceptable when mutually agreed upon by the purchaser and the manufacturer.
- **H.4.3.3.1** Only austenitic type stainless steel hardware shall be used to join aluminum and/or stainless steel components to each other or to carbon steel. Where acceptable to the purchaser and the manufacturer, aluminum hardware may be used to join aluminum components. Aluminum shall be iso-

01

01

lated from carbon steel by an austenitic stainless steel spacer, an elastomeric pad, or equivalent protection.

- **H.4.3.4** Use of any joint sealing compound, insulating material, elastomer or adhesive must be pre-approved by the purchaser. The joining procedure along with test results demonstrating the properties required by this paragraph shall be described completely. Where such joints are permitted, any joint sealing compound, insulating material, elastomeric or adhesive shall be compatible with the product stored, specified service conditions, and with materials joined. Resulting joints shall be equivalent in serviceability (with the basic floating roof components), of a size and strength that will accept the roof design loads without failure or leakage, and shall have an expected life equal to the service life of the roof.
- **H.4.3.5** If specified by the purchaser, all steel plate seams exposed to the product liquid or vapor shall be seal welded (for corrosive service conditions).

#### H.4.4 PERIPHERAL SEALS

**H.4.4.1** A peripheral seal (also referred to as “rim seal”) that spans the annular space between the internal floating roof deck and the shell shall be provided. When an internal floating roof has two such devices, one mounted above the other, the lower is the primary peripheral seal and the upper is the secondary peripheral seal. When there is only one such device, it is a primary peripheral seal, regardless of its mounting position

- **H.4.4.2** The peripheral seal type and material shall be selected by the purchaser after consideration of both proposed and future product service, tank shell construction/condition, maintenance requirements, regulatory compliance, service life expectancy, ambient temperature, design temperature, permeability, abrasion resistance, discoloration, aging, embrittlement, flammability, and other compatibility factors. The various seal types (listed H.4.4.5) will have variable life expectancy and service limitations.

**H.4.4.3** All peripheral seals and their attachment to the floating roof shall be designed to accommodate  $\pm 100$  mm (4 in.) of local deviation between the floating roof and the shell.

**H.4.4.4** The seal material may be fabricated in sections resulting in seams, but any such seam shall be joined or otherwise held tightly together along the entire seam. For peripheral seals that use a fabric material to effect the seal, the requirement in the preceding sentence applies only to the fabric and not to any support devices.

#### H.4.4.5 Seal Types

a. Liquid-mounted rim seal: Means a resilient foam-filled or liquid-filled primary rim seal mounted in a position resulting in the bottom of the seal being normally in contact with the stored liquid surface. This seal may be a flexible foam (such

as polyurethane foam in accordance with ASTM D 3453) or liquid contained in a coated fabric envelope. Circumferential joints on liquid-mounted peripheral seals shall be liquid tight and shall overlap at least 75 mm (3 in.). The material and thickness of the envelope fabric shall be determined after the factors given in H.4.4.2 are considered.

b. Vapor-mounted rim seal: Means a peripheral seal positioned such that it does not normally contact the surface of the stored liquid. Vapor-mounted peripheral seals may include, but are not limited to, resilient-filled seals (similar in design to liquid-mounted rim seals per H.4.4.5.a), secondary mechanical shoe type (similar in design to shoe seals per H.4.4.5.c) and flexible-wiper seals. Flexible-wiper seal means a rim seal comprised of a blade of flexible material such as extruded rubber or synthetic rubber, with or without a reinforcing cloth or mesh.

c. Mechanical shoe (metallic shoe): Means a peripheral seal that utilizes a light-gauge metallic band as the sliding contact with the shell and a fabric seal to close the annular space between the metallic band and the rim of the floating roof deck. The band is typically formed as a series of sheets (shoes) that are overlapped or joined together to form a ring and held against the shell by a series of mechanical devices. Galvanized shoes shall conform to ASTM A 924 and shall have a minimum nominal thickness of 1.5 mm (16 gauge) and a G90 coating. Stainless steel shoes shall conform to H.3.3, and shall have a minimum nominal thickness of 1.2 mm (18 gauge). The primary shoes shall extend at least 150 mm (6 in.) above and at least 100 mm (4 in.) into the liquid at the design flotation level.

#### H.4.5 ROOF PENETRATIONS

Columns, ladders, and other rigid vertical appurtenances that penetrate the deck shall be provided with a seal that will permit a local deviation of  $\pm 125$  mm ( $\pm 5$  in.). Appurtenances shall be plumb within a tolerance of  $\pm 75$  mm ( $\pm 3$  in.).

#### H.4.6 ROOF SUPPORTS

- **H.4.6.1** The floating roof shall be provided with adjustable supports, unless the purchaser specifies fixed supports.
- **H.4.6.2** Unless specified otherwise, the height of the floating roof shall be adjustable to two positions with the tank in service. The design of the supports shall prevent damage to the fixed roof and floating roof when the tank is in an overflow condition.
- **H.4.6.3** The purchaser shall specify clearance requirements to establish the low (operating) and high (maintenance) levels of the roof supports. The purchaser shall provide data to enable the manufacturer to ensure that all tank appurtenances (such as mixers, interior piping, and fill nozzles) are cleared by the roof in its lowest position.

**H.4.6.4** Support attachments in the deck area shall be designed to prevent failure at the point of attachment. On the bottom of the steel welded deck plates (used on types H.2.2. a, b, c, d, and g), where flexure is anticipated adjacent to supports or other relatively rigid members, full-fillet welds not less than 50 mm (2 in.) long on 250 mm (10 in.) centers shall be used on any plate laps that occur within 300 mm (12 in.) of any such support or member.

- **H.4.6.5** Supports shall be fabricated from pipe, unless cable or another type is specified and approved by the purchaser. Supports fabricated from pipe shall be notched or perforated at the bottom to provide drainage.
- **H.4.6.6** Steel pads or other means shall be used to distribute the loads on the bottom of the tank and provide a wear surface. With the purchaser's approval, pads may be omitted if the tank bottom will support the live load plus the dead load of the floating roof. If pads are used, they shall be continuously welded to the tank bottom.
- **H.4.6.7** Aluminum supports shall be isolated from carbon steel by an austenitic stainless steel spacer, an elastomeric bearing pad, or equivalent protection, unless specified otherwise by the purchaser.
- **H.4.6.8** Special protective measures (corrosion allowance, material selection, coatings) are to be evaluated for supports that interface with stratified product bottoms, which may include corrosive contaminant combinations not found in the normal product. The purchaser shall specify if any protective measures are required.

## H.5 Openings and Appurtenances

### H.5.1 LADDER

- **H.5.1.1** The tank interior is considered a confined space environment with restricted access (see API Recommended Practice 2026). If specified by the purchaser, the tank shall be supplied with a ladder for internal floating roof deck access. If a ladder is not supplied and the floating roof is not steel, a ladder landing pad shall be provided on the floating roof.
- H.5.1.2** The ladder shall be designed to allow for the full travel of the internal floating roof, regardless of any settling of the roof supports.
- H.5.1.3** The ladder shall be installed within a fixed-roof manway, per H.5.5.1.
- **H.5.1.4** If a level-gauge stilling well is provided, the well may form one or both legs of the ladder, as specified by the purchaser.
- H.5.1.5** The ladder shall not be attached to the tank bottom unless provision is made for vertical movement at the upper connection.

### H.5.2 VENTS

#### ● H.5.2.1 Internal Floating Roof Pressure-Vacuum (Bleeder) Vents

Vents suitable to prevent overstressing of the roof deck or seal membrane shall be provided on the floating roof. These vents shall be adequate to evacuate air and gases from underneath the roof such that the internal floating roof is not lifted from resting on its supports during filling operations, until floating on the stored liquid. The vents shall also be adequate to release any vacuum generated underneath the roof after it settles on its supports during emptying operations. The purchaser shall specify filling and emptying rates so that the manufacturer can size the vents. Leg activated vents shall be adjustable as required per H.4.6.

#### ● H.5.2.2 Tank Circulation Vents

**H.5.2.2.1** Peripheral circulation vents shall be located on the tank roof (unless otherwise specified by the purchaser) and meet the requirements of H.5.3.3, so that they are above the seal of the internal floating roof when the tank is full. The maximum spacing between vents shall be 10 m (32 ft), based on an arc measured at the tank shell, but there shall not be fewer than four equally spaced vents. The venting shall be distributed such that the sum of the open areas of the vents located within any 10 m (32 ft) interval is at least 0.2 m<sup>2</sup> (2.0 ft<sup>2</sup>). The total net open area of these vents shall be greater than or equal to 0.06 m<sup>2</sup>/m (0.2 ft<sup>2</sup>/ft) of tank diameter. These vents shall be covered with a corrosion-resistant coarse-mesh screen [13 mm (1/2 in.) openings] and shall be provided with weather shields (the closed area of the screen must be deducted to determine the net open vent area).

**H.5.2.2.2** A center circulation vent with a minimum net open area of 30,000 mm<sup>2</sup> (50 in.<sup>2</sup>) shall be provided at the center of the fixed roof or at the highest elevation possible on the fixed roof. It shall have a weather cover and shall be provided with a corrosion-resistant coarse-mesh screen (the closed area of the screen must be deducted to determine the net open vent area).

- **H.5.2.2.3** If circulation vents (per H.5.2.2.1 and H.5.2.2.2) are not installed, gas blanketing or another acceptable method to prevent the development of a combustible gas mixture within the tank is required. Additionally, the tank shall be protected by pressure-vacuum vents in accordance with 3.10.8, based on information provided by the purchaser.

### H.5.3 LIQUID-LEVEL INDICATION AND OVERFLOW SLOTS

- **H.5.3.1** The purchaser shall provide appropriate alarm devices to indicate a rise of the liquid in the tank to a level

above the normal and overflow protection levels (see NFPA 30 and API Recommended Practice 2350). Overflow slots shall not be used as a primary means of detecting an overflow incident.

- **H.5.3.2** The internal floating roof manufacturer shall provide information defining the internal floating roof and seal dimensional profile for the purchasers' determination of the maximum normal operating and overflow protection liquid levels (considering tank fixed roof support, overflow slots or any other top of shell obstructions). The floating roof manufacturer shall provide the design flotation level (liquid surface elevation) of the internal floating roof at which the pressure/vacuum relief vents will begin to open (to facilitate the purchasers' determination of minimum operating levels).
- **H.5.3.3** The use of emergency overflow slots shall only be permitted if specified by the purchaser. When emergency overflow slots are used, they shall be sized to discharge at the pump-in rates for the tank. The greater of the product specific gravity or 1.0 shall be used to determine the overflow slot position so that accidental overfilling will not damage the tank or roof or interrupt the continuous operation of the floating roof. Overflow discharge rates shall be determined by using the net open area (less screen) and using a product level (for determining head pressure) not exceeding the top of the overflow opening. The overflow slots shall be covered with a corrosion-resistant coarse-mesh screen [13 mm ( $1/2$  in.) openings] and shall be provided with weather shields (the closed area of the screen must be deducted to determine the net open area). The open area of emergency overflow slots may contribute to the peripheral venting requirement of H.5.2.2.1 provided that at least 50 percent of the circulation-vent area remains unobstructed during emergency overflow conditions. The floating-roof seal shall not interfere with the operation of the emergency overflow openings. Overflow slots shall not be placed over the stairway or nozzles unless restricted by tank diameter/height or unless overflow piping, collection headers, or troughs are specified by the purchaser to divert flow.

#### H.5.4 ANTIROTATION AND CENTERING DEVICES

The internal floating roof shall be centered and restrained from rotating. A guide pole with rollers, two or more seal centering cables or other suitable device(s) shall be provided as required for this purpose. The internal floating roof shall not depend solely on the peripheral seals or vertical penetration wells to maintain the centered position or to resist rotation. Any device used for either purpose shall not interfere with the ability of the internal floating roof to travel within the full operating elevations in accordance with H.4.1.1.

## H.5.5 MANHOLES AND INSPECTION HATCHES

### H.5.5.1 Fixed-Roof Manholes

At least one fixed roof manhole, with a nominal opening of 600 mm (24 in.) or larger, shall be provided in the fixed roof for maintenance ventilation purposes. If used for access to the tank interior, the minimum clear opening shall be 750mm (30 in.).

### H.5.5.2 Floating-Roof Manholes

At least one internal floating roof deck manhole shall be provided for access to and ventilation of the tank when the floating roof is on its supports and the tank is empty. The manhole shall have a nominal opening of 600 mm (24 in.) or larger and shall be provided with a bolted or secured and gasketed manhole cover. The manhole neck dimensions shall meet the requirements of H.4.1.4 and H.4.1.5.

- **H.5.5.3 Inspection Hatches**

When specified by the purchaser, inspection hatches shall be located on the fixed roof to permit visual inspection of the seal region. The maximum spacing between inspection hatches shall be 23 m (75 ft), but there shall not be fewer than four equally spaced hatches. Designs that combine inspection hatches with tank-shell circulation vents (located on the tank roof) are acceptable.

- **H.5.6 INLET DIFFUSER**

Purchaser shall specify the need for an inlet diffuser sized to reduce the inlet velocity to less than 1 m (3 ft) per second during initial fill per API Recommended Practice 2003. Purchaser shall provide pumping rates and any blending, pigging and recirculation data along with the inlet diameter, for manufacturers determination of the diffuser design and size.

- **H.5.7 GAUGING AND SAMPLING DEVICES**

When specified by the purchaser, the fixed roof and the internal floating roof shall be provided with and/or accommodate gauging and sampling devices.

- **H.5.8 CORROSION GAUGE**

When specified by the purchaser, a corrosion gauge for the internal floating roof shall be provided adjacent to the ladder to indicate the general corrosion rate.

## H.6 Fabrication, Erection, Welding, Inspection, and Testing

- **H.6.1** The applicable fabrication, erection, welding, inspection, and testing requirements of this standard shall be met. Upon the start of internal floating roof installation, or concurrent with assembly within a tank under construction, the tank

(interior shell and vertical components) shall be inspected by the floating roof erector, unless otherwise specified. The purpose of this inspection shall be to confirm plumbness of all interior components, along with roundness and the condition of the shell (for the presence of damage, projections, or obstructions) to verify that the floating roof and seals will operate properly. Any defects, projections, obstructions or tank tolerance limits (exceeding those defined in Section 5.5 of this standard), which would inhibit proper internal floating roof and seal operation, that are identified by the internal floating roof erector shall be reported to the purchaser.

- **H.6.2** Deck seams and other joints that are required to be liquid tight or vapor tight per H.4.1.3 shall be tested by the joint assembler for leaks. Joint testing shall be performed by means of penetrating oil or another method consistent with those described in this standard for testing cone-roof and/or tank-bottom seams, or by any other method mutually agreed upon by the purchaser and the manufacturer.

**H.6.3** Upon assembly and prior to a flotation test, the erector shall inspect to verify that the peripheral seal produces an acceptable fit against the tank shell.

- **H.6.4** A flotation test and initial fill inspection shall be conducted by the purchaser. This test may be performed or witnessed by the erector, as subject to agreement with the purchaser.

- **H.6.4.1** Internal floating roofs in accordance with H.5.1 types H.2.2.a, b, c, d, and g. shall be given a flotation test on water. Internal floating roofs in accordance with types H.2.2.e and H.2.2.f shall be given a flotation test on water or product at the option of the purchaser. During this test, the roof and all accessible compartments shall be checked to confirm that they are free from leaks. The appearance of a damp spot on the upper side of the part in contact with the liquid shall be considered evidence of leakage.

- **H.6.4.2** During initial fill the internal floating roof should be checked to confirm that it travels freely to its full height. The peripheral seal shall be checked for proper operation throughout the entire travel of the internal floating roof.

- **H.6.4.3** Because of possible corrosive effects, consideration shall be given to the quality of water used and the duration of the test. Potable water is recommended. For aluminum or stainless steel floating roofs, S.4.10 shall be followed.

01

01



## APPENDIX I—UNDERTANK LEAK DETECTION AND SUBGRADE PROTECTION

### I.1 Scope and Background

**I.1.1** This appendix provides acceptable construction details for the detection of product leaks through the bottoms of aboveground storage tanks, and provides guidelines for tanks supported by grillage.

Note: API supports a general position of installation of a Release Prevention Barrier (RPB) under new tanks during initial construction. An RPB includes steel bottoms, synthetic materials, clay liners, and all other barriers or combination of barriers placed in the bottom of or under an aboveground storage tank, which have the following functions: (a) preventing the escape of contaminated material, and (b) containing or channeling released material for leak detection.

- **I.1.2** Several acceptable construction details are provided for detection of leaks through the tank bottom and details for tanks supported by grillage (see Figures I-1 through I-11). Alternative details or methods may be used if agreed upon by the tank owner and manufacturer, provided the details or methods satisfy the requirements of I.2.
- **I.1.3** The tank owner shall determine whether the undertank area is to be constructed for leak detection. If leak detection is required, the owner shall specify the method or methods to be employed.

**I.1.4** The bottoms of aboveground storage tanks may leak as a result of topside corrosion, bottomside corrosion, or a combination of both. The extent of topside corrosion can be detected using standard inspection techniques during an internal inspection, but determining the nature and extent of bottomside corrosion is more difficult. Therefore, in certain services and tank locations, it may be desirable to provide for undertank monitoring of leakage through the tank bottom plates.

**I.1.5** For additional information on the use of internal linings to prevent internal bottom corrosion, refer to API Recommended Practice 652. Similarly, refer to API Recommended Practice 651 for guidelines and requirements relating to preventing corrosion from the underside of the bottom plate.

**I.1.6** When the appropriate tank foundation design is being selected, it is important to consider the environmental and safety regulatory implications of leakage of tank contents into the containment space below the tank floor. Specifically, the contamination of permeable material such as sand used as a floor support may constitute the generation of a hazardous waste. The treatment or disposal costs of such contaminated material must be determined.

**I.1.7** The requirements for secondary containment as it relates to diked areas and impoundments are not within the scope of this appendix.

### I.2 Performance Requirements

The following general requirements shall be satisfied for all leak detection systems:

- a. Leaks through the tank bottom shall be detectable by observation at the tank perimeter. If a leak is detected, it shall be collected.
- b. The use of electronic sensors for the detection of vapors and liquids is acceptable; however, the requirements of Item a above shall be satisfied. Any such sensor shall be fail-safe or have provision for calibration.
- c. The materials of construction shall be chemically resistant to the range of products to be stored at the temperature range expected in service. Other physical properties shall be specified by the tank owner.

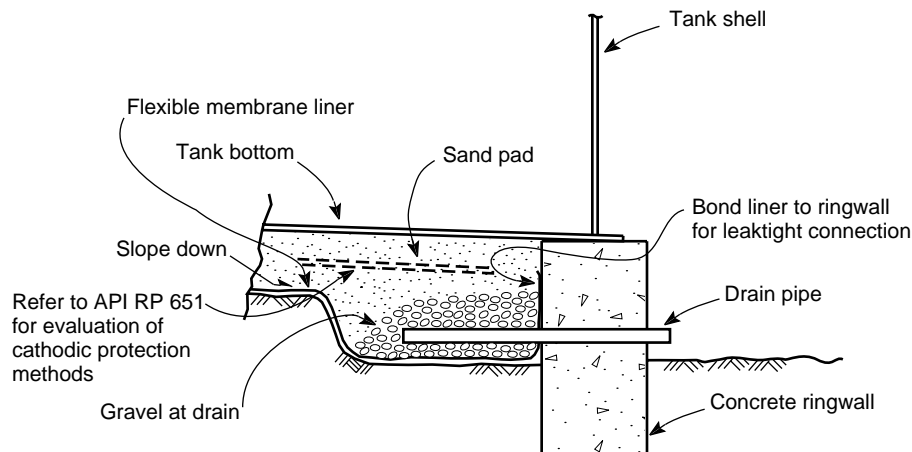

Figure I-1—Concrete Ringwall with Undertank Leak Detection at the Tank Perimeter (Typical Arrangement)

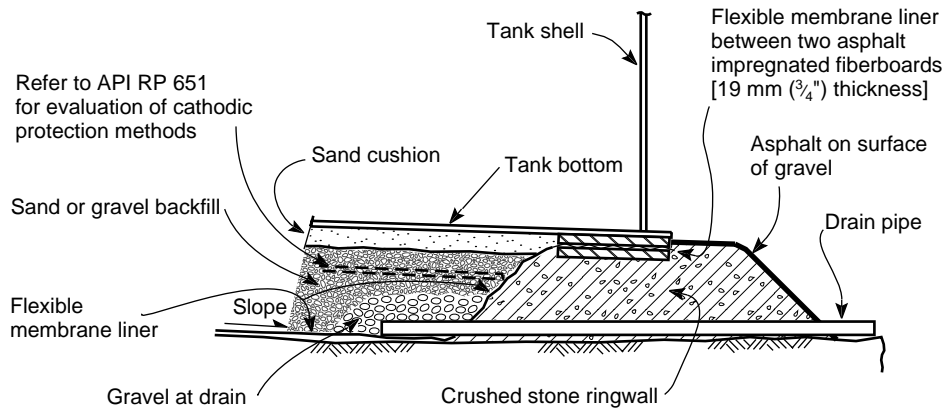

Figure I-2—Crushed Stone Ringwall with Undertank Leak Detection at the Tank Perimeter (Typical Arrangement)

- d. The permeability of the leak detection barrier shall not exceed  $1 \times 10^{-7}$  centimeter (400 mils) per second.
- e. The material in contact with the subgrade shall be suitable for below-grade service or be protected against degradation.
- f. The leak barrier shall be of one-piece construction, or the joints shall satisfy the leak tightness, permeability, and chemical resistance requirements for the base leak-barrier material. The manufacturer and a complete description of the leak barrier material shall be identified to the tank owner.
- g. The installation of sumps and pipes below the tank bottom is acceptable; however, the required leak detection and leak tightness shall be maintained. Refer to Figures I-8 and I-9 for typical details.

### I.3 Cathodic Protection

Cathodic protection systems may be installed in conjunction with undertank leak detection systems. Refer to API Recommended Practice 651 for guidelines on the use of cathodic protection methods.

### I.4 Double Steel Bottom Construction

**I.4.1** If a double steel bottom is used, the details of construction shall provide for the proper support of the primary bottom and shell for all operating conditions. The design shall be evaluated to verify that the primary bottom and shell are not overstressed. The evaluation shall consider all anticipated operating conditions such as design temperature, fill height, hydrostatic testing, seismic conditions, and tank settlement. The evaluation is not required if the primary bottom is uniformly supported on both sides of the shell and is not structurally attached to the secondary bottom or primary bottom support.

**I.4.2** For double steel bottom systems that use steel members (such as grating, structural shapes, or wire mesh) to separate the bottoms, ingress of water between the bottoms will result in local accelerated corrosion rates. If the perimeter of the floors is not sealed, corrosion protection of the tank bottoms shall be provided.

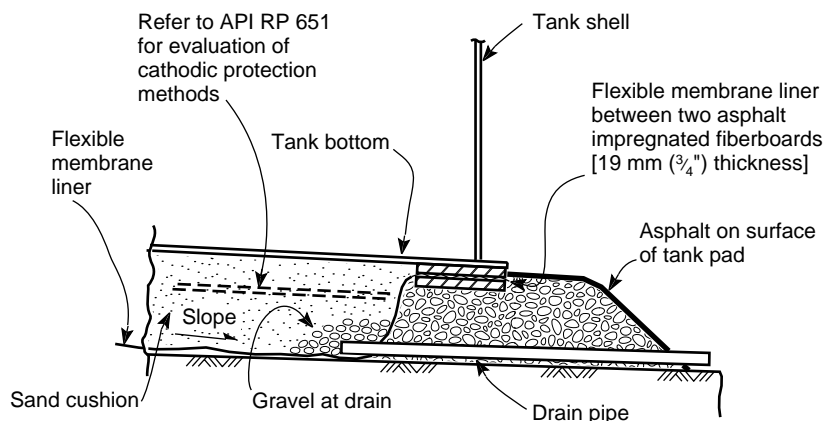

Figure I-3—Earthen Foundation with Undertank Leak Detection at the Tank Perimeter (Typical Arrangement)

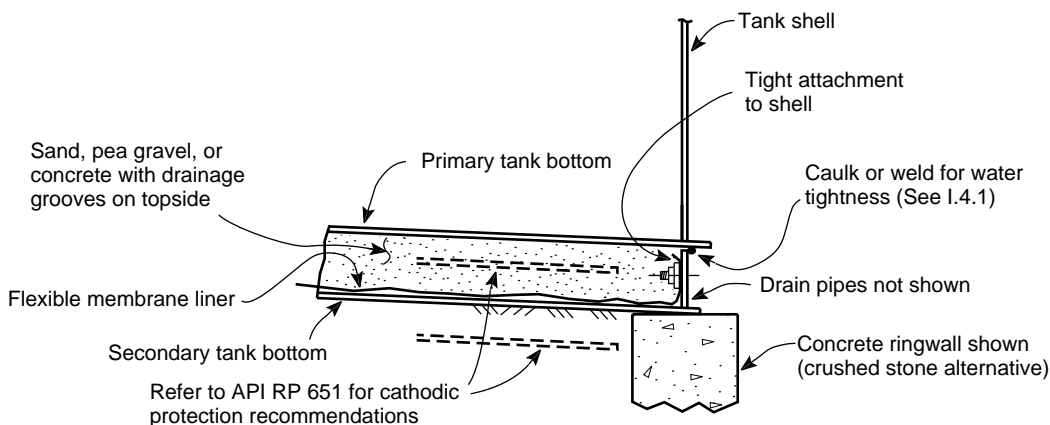

Figure I-4—Double Steel Bottom with Leak Detection at the Tank Perimeter (Typical Arrangement)

### I.5 Material Requirements and Construction Details

**I.5.1** The minimum thickness of flexible-membrane leak barriers shall be 800  $\mu\text{m}$  (30 mils) for fiber-reinforced membranes and 1000  $\mu\text{m}$  (40 mils) for unreinforced membranes. If clay liners are used, they shall be thick enough to meet the permeability requirements of I.2, Item d.

**I.5.2** The leak barrier shall be protected as required to prevent damage during construction. If the foundation fill or tank pad material is likely to cause a puncture in the leak barrier, a layer of sand or fine gravel or a geotextile material shall be used as a protective cushion.

**I.5.3** For a flexible-membrane liner installed over a steel bottom, all nicks, burrs, and sharp edges shall be removed or a layer of fine sand, gravel, or geotextile material shall be used to protect the liner.

**I.5.4** The flexible leak barrier shall be covered by at least 100 mm (4 in.) of sand, except as otherwise shown in Figures I-1 through I-10. This dimension may have to be increased if cathodic protection is to be provided in the space between the tank bottom and the leak barrier.

- I.5.5** If drain pipes are used around the tank perimeter, they shall be at least NPS 1 in diameter and have a minimum wall thickness of Schedule 40. The pipes may be perforated in the

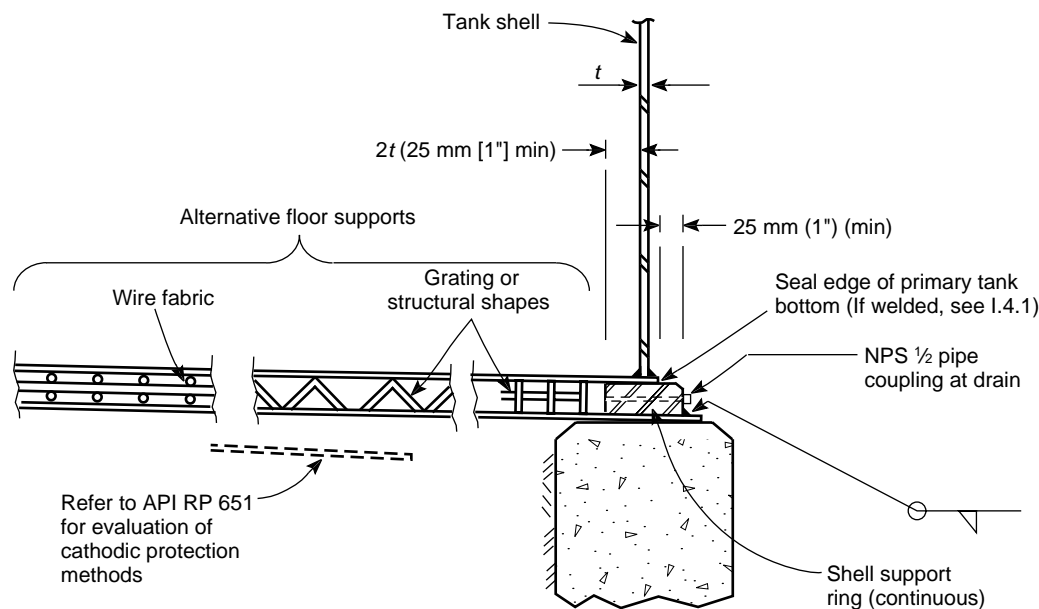

Figure I-5—Double Steel Bottom with Leak Detection at the Tank Perimeter (Typical Arrangement)

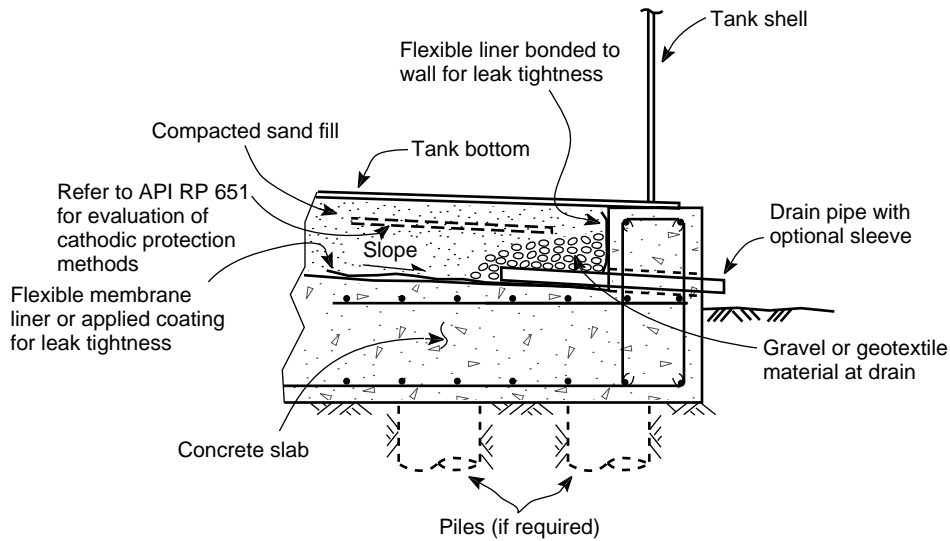

Figure I-6—Reinforced Concrete Slab with Leak Detection at the Perimeter (Typical Arrangement)

undertank area to improve their leak detection function. The inner ends and perforations of the drain pipes shall be protected from clogging by the use of gravel, screening, geotextiles, or another method approved by the tank owner. The drain pipes shall exit through the foundation and shall be visible to indicate any leakage. If specified by the owner, the undertank drains shall be fitted with a valve or piped to a leak detection well as shown in Figure I-10. The maximum spacing of drain pipes shall be 15 m (50 ft), with a minimum of four drain pipes per tank; however, two drain pipes may be used for tanks 6 m (20 ft) or less in diameter.

**I.5.6** The need for pipe sleeves, expansion joints, or both in conjunction with drain pipes shall be evaluated.

**I.5.7** The outlet of the drain pipes and collection sumps, if used, shall be protected from the ingress of water from external sources.

**I.5.8** Leak detection systems that use sumps in the liner below the tank bottom shall have a drain line that extends from the sump to the tank perimeter. Consideration shall be given to installation of supplemental perimeter drains.

## I.6 Testing and Inspection

**I.6.1** The leak barrier, all leak-barrier penetrations, attachments of the leak barrier to the foundation ringwall, and other appurtenances shall be visually inspected for proper construction in accordance with applicable specifications.

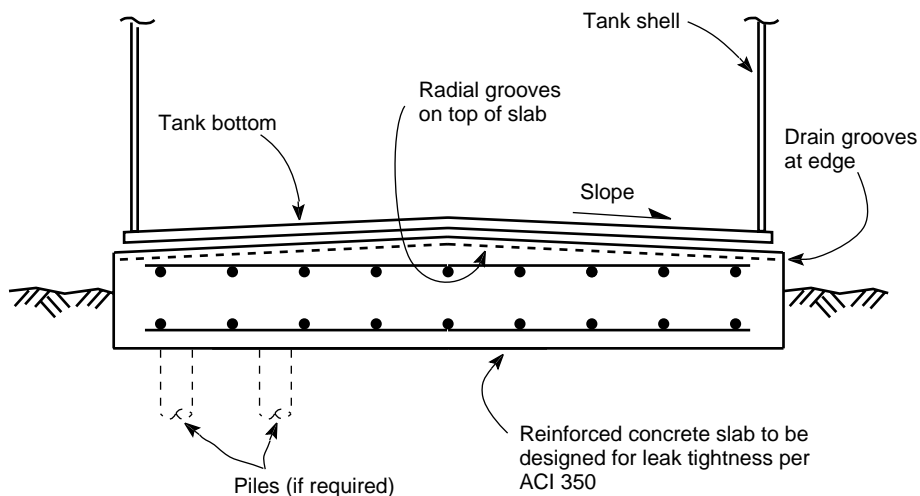

Figure I-7—Reinforced Concrete Slab with Radial Grooves for Leak Detection (Typical Arrangement)

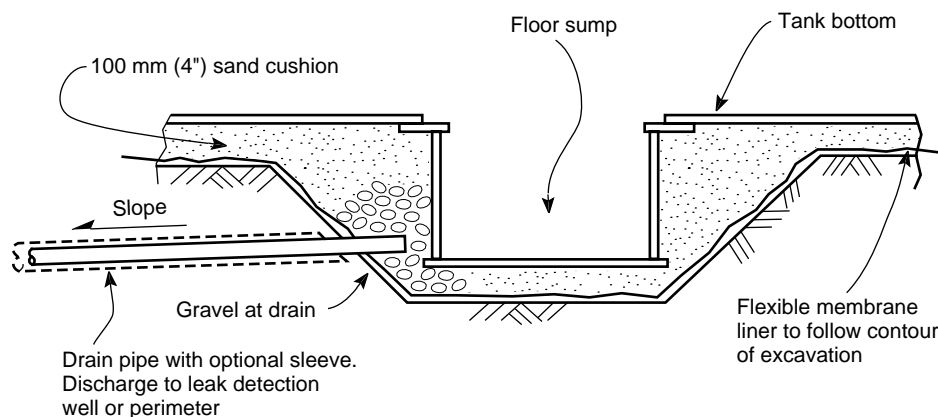

Figure I-8—Typical Drawoff Sump

- **I.6.2** The shop and field seams of flexible-membrane liners shall pass a vacuum-box test. All leaks shall be repaired and retested. Alternative testing methods may be used with the tank owner's approval.
- **I.6.3** Proof testing of samples of the flexible-membrane liner seam shall be performed to verify the seam strength and flexibility and the adequacy of the bonding. The procedure (including testing methods) used to bond or weld the liner seams shall be submitted to the owner for review and shall specify all critical parameters, such as temperature, speed, surface preparation, and curing time, required to achieve liquid-tight seams. The required strength and flexibility of the liner seams shall be agreed upon by the tank owner and manufacturer. The seam samples shall be produced at the beginning of each shift for each operator and welding machine.
- **I.6.4** All liner penetrations, attachments of the liner to the foundation ringwall, and other appurtenances shall be demonstrated to be leak tight. This may be demonstrated by a mock-up test, prior experience, or other methods acceptable to the owner.

## I.7 Tanks Supported by Grillage

- **I.7.1** Tanks designed and constructed in accordance with API 650 standard that have a maximum nominal shell thickness of 13 mm ( $1/2$  in.), including any customer specified corrosion allowance, and operating temperatures not exceeding 90°C (200°F) may be supported by steel or concrete grillage. By agreement between the purchaser and manufacturer, these rules may be applied to tanks with shell thickness greater than 13 mm ( $1/2$  in.). These rules apply to single steel butt-welded bottoms supported by grillage members.

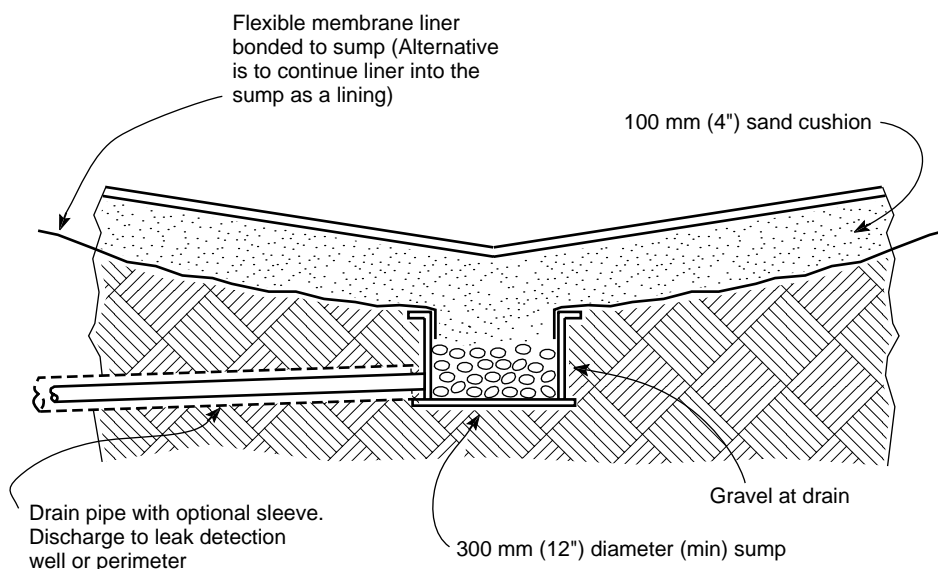
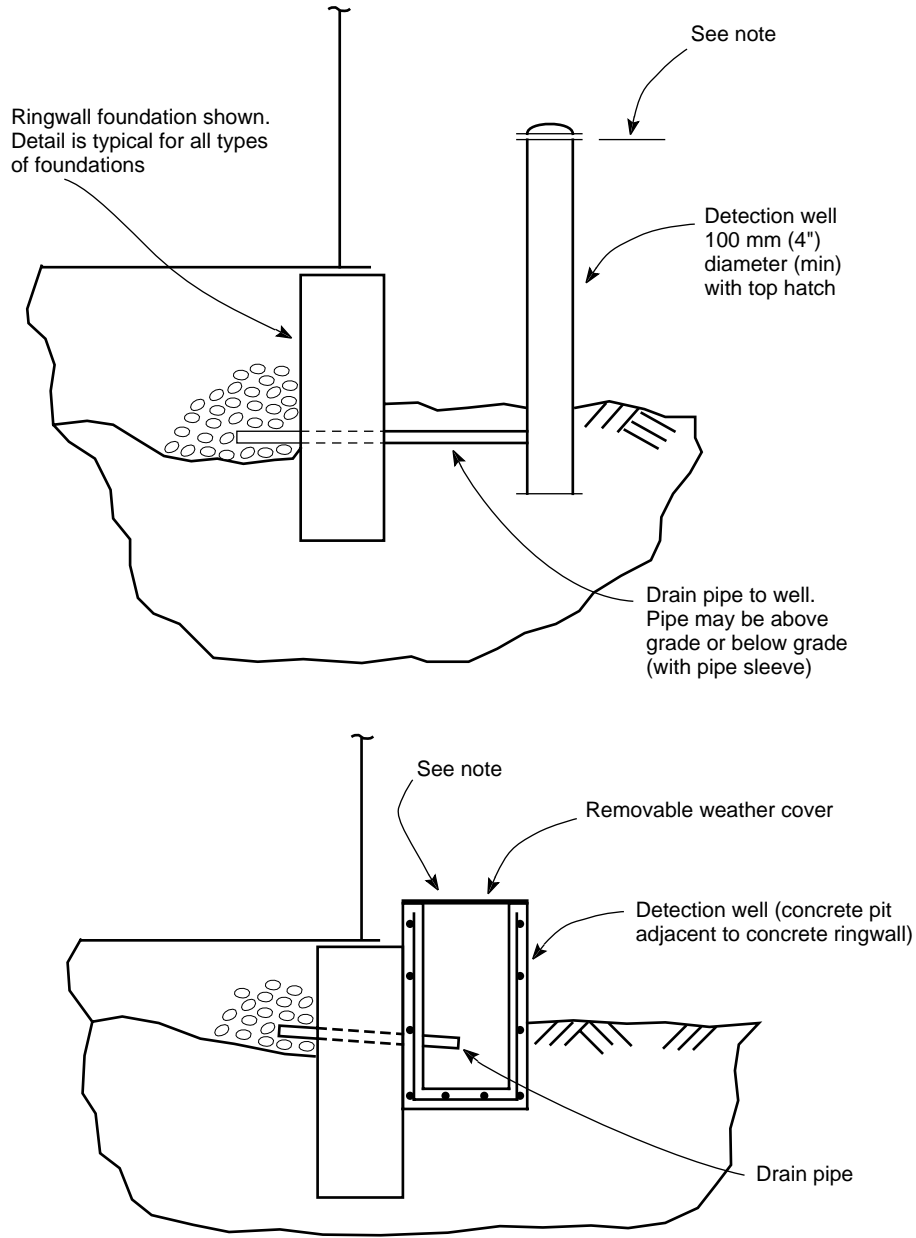

Figure I-9—Center Sump for Downward-Sloped Bottom



Note: Top of well shall be above maximum high water level within dike.

Figure I-10—Typical Leak Detection Wells

**1.7.2** The thickness and design metal temperature of the bottom plate shall be in accordance with Figure 2-1.

**1.7.3** The maximum spacing between adjacent or radial grillage members and the bottom plate thickness shall satisfy the requirements of 1.7.3.1 and 1.7.3.2.

**1.7.3.1** The maximum spacing between adjacent or radial grillage members shall not exceed:

$$b = \left[ \frac{1.5F_y (t_g - CA)^2}{p} \right]^{0.5}$$

**1.7.3.2** The required minimum thickness of the bottom plate supported on grillage shall be determined by the following equation:

$$t_g = \left[ \frac{b^2(p)}{1.5F_y} \right]^{0.5} + CA$$

where

$b$  = maximum allowable spacing (center-to-center) between adjacent or radial grillage members, in mm (in.),

$F_y$  = Specified minimum yield strength of bottom plate material, in MPa (psi),

$t_g$  = nominal thickness (including any corrosion allowance) of the bottom plate supported on grillage, in mm (in.),

•  $CA$  = corrosion allowance to be added to the bottom plate, in mm (in.). The purchaser shall specify the corrosion allowance,

$p$  = uniform pressure (including the weight of the bottom plate) acting on the bottom resulting from the greater of the weight of the product plus any internal pressure, or the weight of the hydrostatic test water, in MPa (psi).

**1.7.3.3** The maximum calculated deflection of the bottom plate at mid-span shall not exceed  $(t_g - CA) / 2$ :

$$d = \frac{0.0284pb^4}{E_s(t_g - CA)^3} \leq (t_g - CA) / 2$$

where

$d$  = maximum calculated deflection of the bottom plate at mid-span, in mm (in.),

$E_s$  = modulus of elasticity of the bottom plate material, in MPa (psi).

**1.7.4** The bottom plates shall be jointed together by butt-welds having complete penetration and complete fusion. Joints shall be visually inspected prior to welding to ensure the weld gap and fit-up will allow complete penetration. Each weld pass shall be visually inspected. The alignment and spacing of grillage members shall be such that the joints between bottom plates are located approximately above the center of the grillage members to the greatest extent practical. Grillage members shall be arranged to minimize the length of unsupported tank shell spanning between grillage members.

**1.7.5** Grillage members shall be symmetrical about their vertical centerline. Steel grillage members shall be designed to prevent web crippling and web buckling as specified in Chapter K of the AISC *Manual of Steel Construction, Allowable Stress Design*.<sup>3</sup> Concrete grillage members may also be used.

• **1.7.6** The purchaser shall specify the corrosion allowance to be added to steel grillage members. If a corrosion allowance is required, the manner of application (added to webs only, added to webs and flanges, added to one surface, added to all surfaces, and so forth) shall also be specified.

**1.7.7** For tanks designed to withstand wind or seismic loads, provisions shall be made to prevent sliding, distortion, and overturning of the grillage members. Lateral bracing between the top and bottom flanges of adjacent steel grillage members may be required to prevent distortion and overturning. The lateral bracing and connections shall be designed to transfer the specified lateral loads. If friction forces between the grillage members and the foundation are not adequate to transfer the specified lateral load, the grillage members shall be anchored to the foundation.

**1.7.8** The tank shall be anchored to resist uplift forces (in excess of the corroded dead load) due to pressure and wind or seismic overturning. Anchors shall be located near the intersection of the tank shell and a grillage member, or near an additional stiffening member.

**1.7.9** The tank shell shall be designed to prevent local buckling at the grillage members and consideration shall be given to shell distortion when the spacing of the grillage members is determined.

**1.7.10** The bottom plate and grillage members directly beneath roof support columns and other items supported by the bottom shall be designed for the loads imposed. Additional support members are to be furnished if required to adequately support the bottom.

**1.7.11** If flush-type cleanouts or flush-type shell connections are furnished, additional support members shall be provided to adequately support the bottom-reinforcing and bottom-transition plates. As a minimum, the additional support members shall consist of a circumferential member

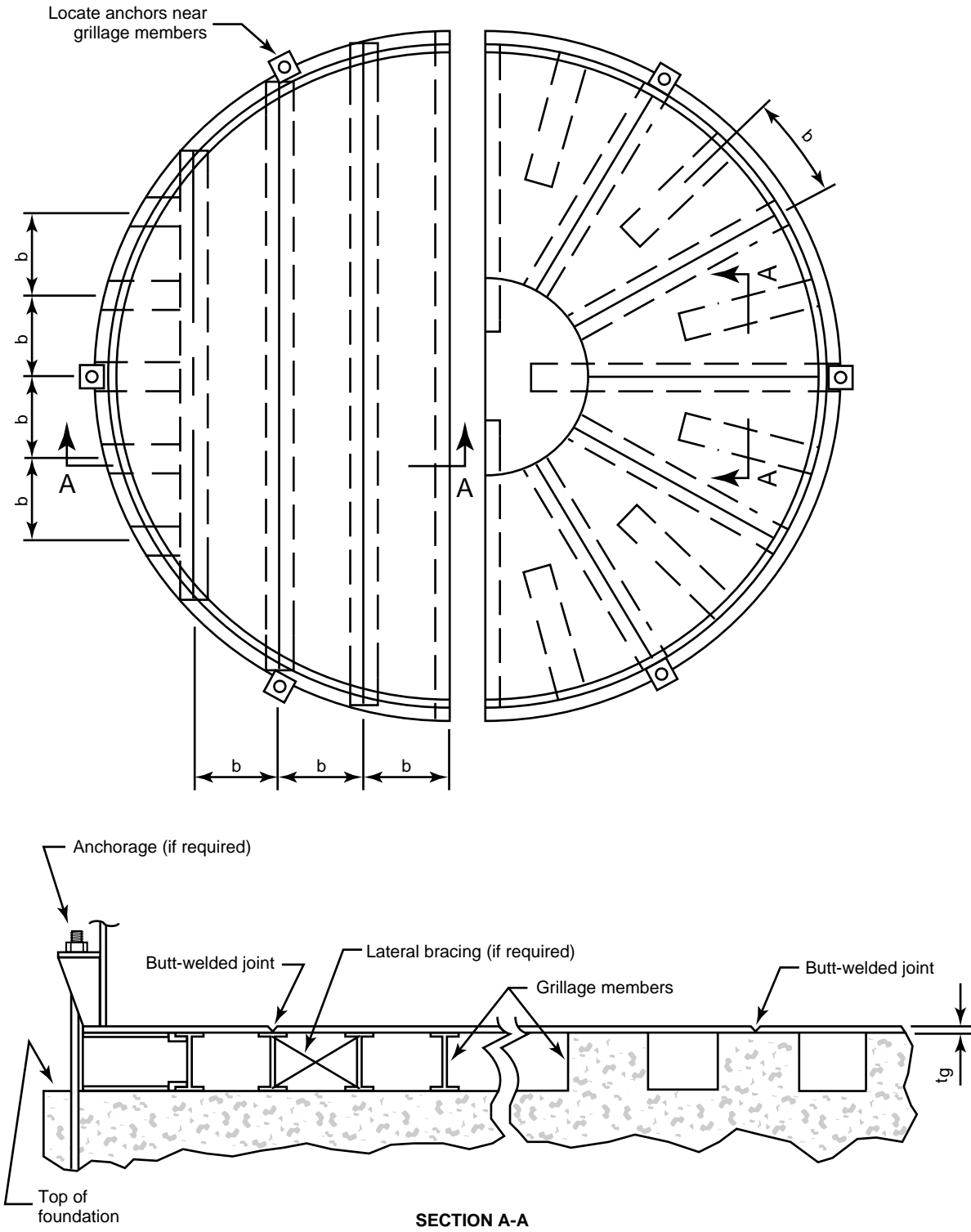

Figure I-11—Tanks Supported by Grillage Members (General Arrangement)

- (minimum length and location according to Method A of Figure 3-10) and radial support members. The radial support members shall extend from the circumferential member to the inner edge of the bottom reinforcing (for flush-type cleanouts) or bottom transition plate (for flush-type shell connections). The circumferential spacing of the radial support members shall not exceed 300 mm (12 in.).

**1.7.12** For tanks located in a corrosive environment, and where atmospheric corrosion due to wet/dry cycles may occur, consideration shall be given to protecting the underside of the bottom plates, grillage members, and in particular, the

contact surface between the bottom plates and grillage members by utilizing protective coatings or by adding a corrosion allowance to these members.

## I.8 Typical Installations

Although it is not the intent of this appendix to provide detailed designs for the construction of undertank leak detection systems and tanks supported by grillage, Figures I-1 through I-11 illustrate the general use and application of the recommendations presented in this appendix.



## APPENDIX J—SHOP-ASSEMBLED STORAGE TANKS

### J.1 Scope

**J.1.1** This appendix provides requirements for the design and fabrication of vertical storage tanks in sizes that permit complete shop assembly and delivery to the installation site in one piece. Storage tanks designed according to this appendix shall not exceed 6 m (20 ft) in diameter.

- **J.1.2** The application of this appendix to the design and fabrication of shop-assembled storage tanks shall be mutually agreed upon by the purchaser and the manufacturer.

### J.2 Materials

The material requirements of Section 2 of this standard are applicable.

### J.3 Design

#### J.3.1 JOINTS

**J.3.1.1** Joints shall be designed as specified in 3.1; however, lap-welded joints in bottoms are not permissible. In addition, the modifications given in J.3.1.2 through J.3.1.5 are applicable.

**J.3.1.2** All shell joints shall be butt welded so that full penetration is produced without the use of backup bars.

**J.3.1.3** Shell plates shall be sized to limit the number of plates to the smallest practical number consistent with sound economic practice. Each course should preferably be constructed of one plate.

**J.3.1.4** Top angles are not required for flanged-roof tanks.

**J.3.1.5** Joints in bottom plates shall be butt-welded. The welding shall produce complete penetration of the parent metal.

#### J.3.2 BOTTOMS

- **J.3.2.1** All bottom plates shall have a minimum nominal thickness of 6 mm ( $1/4$  in.) [70 kPa (10.2 lbf/ft<sup>2</sup>), see 2.2.1.2 and 3.4.1].

**J.3.2.2** Bottoms shall be constructed of a minimum number of pieces; wherever feasible they shall be constructed of one piece.

**J.3.2.3** Bottoms may be flat or flat flanged. A flat bottom shall project at least 25 mm (1 in.) beyond the outside diameter of the weld attaching the bottom to the shell plate. A flat-flanged bottom shall have an inside corner radius that is not less than three times the bottom thickness and a straight flange that is a minimum of 19 mm ( $3/4$  in.).

**J.3.2.4** For flat bottoms, the attachment between the bottom edges of the lowest course shell plate and the bottom plate shall be a continuous fillet weld laid on each side of the shell plate. Each fillet weld shall be sized in accordance with 3.1.5.7. A flat-flanged bottom shall be attached to the shell by full-penetration butt-welds.

#### J.3.3 SHELLS

Shell plates shall be designed in accordance with the formula given in A.4.1, but the nominal thickness of shell plates shall not be less than the following:

- a. For tanks with a diameter less than or equal to 3.2 m (10.5 ft) – 5 mm ( $3/16$  in.).
- b. For tanks with a diameter greater than 3.2 m (10.5 ft) – 6 mm ( $1/4$  in.).

#### J.3.4 WIND GIRDERS FOR OPEN-TOP TANKS

Open-top tanks shall be provided with wind girders as specified in 3.9.

#### J.3.5 ROOFS

##### J.3.5.1 General

Roofs for tanks constructed in accordance with this appendix shall be of the self-supporting type and shall conform to either J.3.5.2 or J.3.5.3.

##### J.3.5.2 Cone Roofs

Self-supporting cone roofs shall be designed as specified in 3.10.5, except they may be provided with a flange that will permit butt-welded attachment to the shell (see J.3.1.4). Flanges shall be formed with a minimum inside corner radius of three times the roof thickness or 19 mm ( $3/4$  in.), whichever is larger.

##### J.3.5.3 Dome and Umbrella Roofs

Self-supporting dome and umbrella roofs shall be designed as specified in 3.10.6, except they may be flanged as described in J.3.5.2. For dome roofs that are flanged, the radius of curvature shall not be limited to the maximum requirements given in 3.10.6; instead, the curvature shall be limited by the depth of the roof, including the crown and knuckle depth, as listed in Table J-1.

##### J.3.5.4 Top Angles

When top angles are required, they shall be attached as specified in 3.10.7.

Table J-1—Maximum Roof Depths for Shop-Assembled Dome-Roof Tanks

Diameter		Depth	
m	ft	mm	in.
≤ 1.8	6	50	2
≤ 2.4	8	90	3½
≤ 3.0	10	140	5½
≤ 3.7	12	200	8
≤ 4.3	14	275	11
≤ 4.9	16	375	15
≤ 6.0	20	500	20

### J.3.6 TANK CONNECTIONS AND APPURTENANCES

**J.3.6.1** Manholes, nozzles, and other connections in the shell shall be constructed and attached as specified in 3.7, but it is unlikely that reinforcing plates will be required for manholes and nozzles in the tank shell. The need for reinforcement shall be checked according to the procedure given in 3.7.2. Since the minimum shell-plate thicknesses given in J.3.3 will normally exceed the calculated thickness, the excess material in the shell should satisfy the reinforcement requirements in nearly all cases.

- **J.3.6.2** The roofs of tanks constructed in accordance with this appendix will be inherently strong because of the limitations in diameter required for shipping clearances. Thus, reinforcement of roof manholes and nozzles is not required unless specifically requested by the purchaser or unless roof loads exceed 1.2 kPa (25 lbf/ft<sup>2</sup>), in which case the amount and type of reinforcement shall be agreed upon by the purchaser and the manufacturer.

### J.3.7 CORROSION ALLOWANCE

- **J.3.7.1** If the purchaser requires that a corrosion allowance be provided, the allowance and the areas to which the allowance is to be added shall be specified. If a corrosion allowance is specified without an indication of the area to which it is to be added, the manufacturer shall assume that it is to be added only to the calculated shell-plate thickness.
- **J.3.7.2** When a corrosion allowance is specified for the roof and bottom plates, it shall be added to the minimum nominal thicknesses.

### J.3.8 LIFTING LUGS

**J.3.8.1** Lugs or clips for use in loading and unloading tanks and for use in placing tanks on foundations shall be provided on all tanks constructed in accordance with this appendix.

- **J.3.8.2** There shall be a minimum of two lugs on each tank. The location of the lugs shall be agreed upon by the purchaser and the manufacturer. The lugs shall preferably be located at the top of the tank, in pairs, 180 degrees apart.

**J.3.8.3** Lugs and their attachment welds shall be designed to carry their share of the applied load (twice the empty weight of the tank) distributed in a reasonable manner and based on a safety factor of 4.

**J.3.8.4** Lugs capable of carrying the load described in J.3.8.3 shall be designed and attached in a manner that will not damage the tank.

### J.3.9 ANCHORING

Because of the proportions of shop-assembled storage tanks, overturning as a result of wind loading must be considered. If necessary, adequate provisions for anchoring shall be provided.

## J.4 Fabrication and Construction

### J.4.1 GENERAL

**J.4.1.1** Fabrication and construction shall be in accordance with the applicable provisions of Sections 4 and 5 of this standard. Erection shall be interpreted as assembly, and it shall be understood that the entire vessel is constructed in the shop and not at the field site.

**J.4.1.2** Paragraphs 5.2.2 and 5.2.5 of this standard are not applicable to the bottoms and roofs of shop-assembled tanks.

### J.4.2 TESTING, REPAIRS, AND INSPECTION

#### J.4.2.1 General

For testing of, repairs to, and inspection of shop-assembled tanks, the requirements of J.4.2.2 through J.4.2.4 replace those of 5.3.2 through 5.3.7.

#### ● J.4.2.2 Testing

Unless otherwise specified by the purchaser, as an alternative to the requirements of 5.3.2 through 5.3.7, a tank may be shop tested for leaks by the following method:

- The tank bottom shall be braced by securely attaching an external stiffening member as required to prevent permanent deformation during the test.
- All openings shall be closed with plugs or covers as needed. Bolts and gaskets of the size and type required for final installation shall be used during the test.
- An internal air pressure of 14 to 21 kPa (2 to 3 lbf/in.<sup>2</sup>) gauge shall be applied to the tank. For tanks with a diameter of 3.7 m (12 ft) or less, a maximum pressure of 35 kPa (5 lbf/in.<sup>2</sup>) gauge shall be used.

d. A soap film, linseed oil, or another material suitable for the detection of leaks shall be applied to all shell, bottom, roof, and attachment welds, and the tank shall be carefully examined for leaks.

e. After the air pressure is released, the external stiffening member shall be removed, and any weld scars shall be repaired.

#### **J.4.2.3 Repairs**

All weld defects found by the leak test or by radiographic examination shall be repaired as specified in Section 6.

#### **J.4.2.4 Inspection**

01 | The purchaser's inspector shall have free entry to the manufacturer's shop at all times. The manufacturer shall afford the purchaser's inspector reasonable facilities to assure the inspector that the work is being performed in accordance with the requirements of this standard. All material and workmanship shall be subject to the replacement requirements of 4.2.3.

### **J.5 Inspection of Shell Joints**

The methods of inspecting shell joints described in Section 6 apply to shop-assembled tanks, but spot radiography may be omitted when a joint efficiency of 0.70 is used (see A.3.4).

### **J.6 Welding Procedure and Welder Qualifications**

The requirements for qualification of welding procedures and welders given in Section 7 apply to shop-assembled tanks.

### **J.7 Marking**

Shop-assembled tanks shall be marked in accordance with Section 8, except that 8.1.4 and 8.2 are not applicable. The nameplate (see Figure 8-1) shall indicate that the tank has been designed in accordance with this appendix.



## APPENDIX K—SAMPLE APPLICATION OF THE VARIABLE- DESIGN-POINT METHOD TO DETERMINE SHELL-PLATE THICKNESS

### K.1 Data

[ ] Design condition      [X] Test condition

Specific gravity of liquid, $G$ :	1.0
Corrosion allowance:	0.0 mm (0.0 in.)
Tank diameter, $D$ :	85.0 m (280 ft)
Total height of tank, $H$ :	19.2 m (64 ft)
Number of courses:	8.0
Allowable stress for design, $S_d$ :	—
Allowable stress for testing, $S_t$ :	208 MPa (30,000 lbf/in. <sup>2</sup> )
Height of bottom course, $h_1$ :	2,400 mm (96 in.)
Nominal tank radius, $r$ :	42,500 mm (1,680 in.)

(See 3.6.4 for definition of nomenclature.)

### K.2 Calculations

#### K.2.1 FIRST COURSE ( $t_1$ )

For the test condition,  $t_1$  is equal to  $t_{1t}$  but not greater than  $t_{pt}$ .

In SI units:

$$\begin{aligned}
 t_{pt} &= \frac{4.9D(H-0.3)}{S_t} = \frac{(4.9)(85)(19.2-0.3)}{208} = 37.85 \\
 t_{1t} &= \left[ 1.06 - \frac{0.0696D}{H} \sqrt{\frac{H}{S_t}} \right] \left[ \frac{(4.9HD)}{S_t} \right] \\
 &= \left[ 1.06 - \frac{0.0696(85)}{19.2} \sqrt{\frac{19.2}{208}} \right] \left[ \frac{4.9(19.2)(85)}{208} \right] \\
 &= [1.06 - (0.3081)(0.3038)][38.45] \\
 &= [1.06 - 0.0936][38.45] \\
 &= [0.9664][38.45] \\
 &= 37.15 \text{ mm} = t_1
 \end{aligned}$$

In US Customary units:

$$\begin{aligned}
 t_{pt} &= \frac{2.6D(H-1)}{S_t} = \frac{2.6(280)(64-1)}{30,000} = 1.529 \\
 t_{1t} &= \left[ 1.06 - \frac{(0.463D)}{H} \sqrt{\frac{H}{S_t}} \right] \left[ \frac{(2.6HD)}{S_t} \right] \\
 &= \left[ 1.06 - \frac{0.463(280)}{64} \sqrt{\frac{64}{30,000}} \right] \left[ \frac{2.6(64)(280)}{30,000} \right] \\
 &= [1.06 - (2.026)(0.0462)][1.553] \\
 &= [1.06 - 0.0936][1.553] \\
 &= [0.9664][1.553] \\
 &= 1.501 \text{ in.} = t_1
 \end{aligned}$$

**K.2.2 SECOND COURSE ( $t_2$ )**

In SI units:

$$\frac{h_1}{(rt_1)^{0.5}} = \frac{2400}{[(42,500)(37.2)]^{0.5}} = 1.909$$

$$\text{If } \frac{h_1}{(rt_1)^{0.5}} \leq 1.375, t_2 = t_1; \quad \text{if } \frac{h_1}{(rt_1)^{0.5}} \geq 2.625, t_2 = t_{2a}$$

$$\text{If } 1.375 < \frac{h_1}{(rt_1)^{0.5}} < 2.625$$

$$\begin{aligned} t_2 &= t_{2a} + (t_1 - t_{2a}) \left[ 2.1 - \frac{h_1}{1.25(rt_1)^{0.5}} \right] \\ &= 31.28 + (5.87) \left[ 2.1 - \frac{2400}{1.25[(42,500)(37.16)]^{0.5}} \right] \\ &= 31.28 + (5.87)[2.1 - 1.528] \\ &= 31.28 + (5.87)[0.572] \\ &= 31.28 + 3.36 \\ &= 34.64 \text{ mm} \end{aligned}$$

In US Customary units:

$$\frac{h_1}{(rt_1)^{0.5}} = \frac{96}{[(1680)(1.501)]^{0.5}} = \frac{96}{50.216} = 1.912$$

$$\text{If } \frac{h_1}{(rt_1)^{0.5}} \leq 1.375, t_2 = t_1; \quad \text{if } \frac{h_1}{(rt_1)^{0.5}} \geq 2.625, t_2 = t_{2a}$$

$$\text{If } 1.375 < \frac{h_1}{(rt_1)^{0.5}} < 2.625$$

$$\begin{aligned} t_2 &= t_{2a} + (t_1 - t_{2a}) \left[ 2.1 - \frac{h_1}{1.25(rt_1)^{0.5}} \right] \\ &= 1.263 + (0.238) \left[ 2.1 - \frac{96}{1.25[(1680)(1.501)]^{0.5}} \right] \\ &= 1.263 + (0.238)[2.1 - 1.529] \\ &= 1.263 + (0.238)[0.571] \\ &= 1.263 + 0.136 \\ &= 1.399 \text{ in.} \end{aligned}$$

**K.2.3 UPPER COURSES****K.2.3.1 Course 2**

Note:  $H = 16.8$  m (56 ft).

**K.2.3.1.1 First Trial**

In SI units:

$$t_{tx} = \frac{4.9D(H - 0.3)}{S_t} = \frac{4.9(85)(16.8 - 0.3)}{208}$$

$$= 33.04 \text{ mm} = t_u$$

$$t_L = 37.15 \text{ mm}$$

$$K = \frac{t_L}{t_u} = \frac{37.15}{33.04} = 1.124$$

$$K^{0.5} = 1.060$$

$$C = \frac{K^{0.5}(K - 1)}{1 + K^{1.5}} = \frac{(1.06)(0.124)}{1 + 1.192} = 0.060$$

$$(rt_u)^{0.5} = [(42,500)(33.04)]^{0.5} = 1185.0$$

$$x_1 = 0.61(rt_u)^{0.5} + 320CH$$

$$= 0.61(1185) + 320(0.060)(16.8) = 1045.4$$

$$x_2 = 1000CH = 1000(0.060)(16.8) = 1008$$

$$x_3 = 1.22(rt_u)^{0.5} = 1.22(1185) = 1445.7$$

$$x = \min(x_1, x_2, x_3) = 1008$$

$$x/1000 = 1.008$$

$$t_{tx} = \frac{4.9D(H - x)}{S_t} = \frac{4.9(85)(16.8 - 1.008)}{208} = 31.62 \text{ mm}$$

In US Customary units:

$$t_{tx} = \frac{2.6D(H - 1)}{S_t} = \frac{2.6(280)(55)}{30,000}$$

$$= 1.335 \text{ in.} = t_u$$

$$t_L = 1.501 \text{ in.}$$

$$K = \frac{t_L}{t_u} = \frac{1.501}{1.335} = 1.124$$

$$K^{0.5} = 1.060$$

$$C = \frac{K^{0.5}(K - 1)}{1 + K^{1.5}} = \frac{(1.06)(0.124)}{1 + 1.191} = 0.060$$

$$(rt_u)^{0.5} = [(1680)(1.335)]^{0.5} = 47.358$$

$$x_1 = 0.61(rt_u)^{0.5} + 3.84CH$$

$$= 0.61(47.358) + 3.84(0.060)(56) = 28.89 + 12.90 = 41.79$$

$$x_2 = 12CH = 12(0.060)(56) = 40.32$$

$$x_3 = 1.22(rt_u)^{0.5} = 1.22(47.358) = 57.78$$

$$x = \min(x_1, x_2, x_3) = 40.32$$

$$x/12 = 3.36$$

$$t_{tx} = \frac{2.6D(H - x/12)}{S_t} = \frac{2.6(280)(56 - 3.36)}{30,000} = 1.277 \text{ in.}$$

With this value of  $t_{tx}$ , start the second trial.

**K.2.3.1.2 Second Trial**

In SI units:

$$t_u = t_{tx} \text{ from first trial} = 31.62 \text{ mm}$$

$$t_L = 37.15 \text{ mm}$$

$$K = \frac{t_L}{t_u} = \frac{37.15}{31.62} = 1.175$$

$$K^{0.5} = 1.084$$

$$C = \frac{K^{0.5}(K-1)}{1+K^{1.5}} = \frac{(1.084)(0.175)}{1+1.175^{1.5}} = 0.0834$$

$$(rt_u)^{0.5} = [(42,500)(31.62)]^{0.5} = 1159.2$$

$$\begin{aligned} x_1 &= 0.61(rt_u)^{0.5} + 320CH \\ &= 0.61(1159.2) + 320(0.0834)(16.8) = 1155.5 \end{aligned}$$

$$x_2 = 1000CH = 1000(0.0834)(16.8) = 1401.1$$

$$x_3 = 1.22(rt_u)^{0.5} = 1.22(1159.2) = 1414.2$$

$$x = \min(x_1, x_2, x_3) = 1155.5$$

$$x/1000 = 1.155$$

$$t_{tx} = \frac{4.9D(H-x/1000)}{S_t} = \frac{4.9(85)(16.8-1.155)}{208} = 31.33 \text{ mm}$$

In US Customary units:

$$t_u = t_{tx} \text{ from first trial} = 1.277 \text{ in.}$$

$$t_L = 1.501 \text{ in.}$$

$$K = \frac{t_L}{t_u} = \frac{1.501}{1.277} = 1.175$$

$$K^{0.5} = 1.084$$

$$C = \frac{K^{0.5}(K-1)}{1+K^{1.5}} = \frac{(1.084)(0.175)}{1+1.274} = 0.0834$$

$$(rt_u)^{0.5} = [(1680)(1.277)]^{0.5} = 46.32$$

$$\begin{aligned} x_1 &= 0.61(rt_u)^{0.5} + 3.84CH \\ &= 0.61(46.32) + 3.84(0.0834)(56) = 28.25 + 17.93 = 46.19 \end{aligned}$$

$$x_2 = 12CH = 12(0.0834)(56) = 56.04$$

$$x_3 = 1.22(rt_u)^{0.5} = 1.22(46.32) = 56.51$$

$$x = \min(x_1, x_2, x_3) = 46.19$$

$$x/12 = 3.80$$

$$t_{tx} = \frac{2.6D(H-x/12)}{S_t} = \frac{2.6(280)(56-3.80)}{30,000} = 1.267 \text{ in.}$$

With this value of  $t_{tx}$ , start the third trial.

**K.2.3.1.3 Third Trial**

In SI units:

$$t_u = t_{tx} \text{ from second trial} = 31.33 \text{ mm}$$

$$t_L = 37.15 \text{ mm}$$

$$K = \frac{t_L}{t_u} = \frac{37.15}{31.33} = 1.186$$

$$K^{0.5} = 1.089$$

$$C = \frac{K^{0.5}(K-1)}{1+K^{1.5}} = \frac{(1.089)(0.186)}{1+1.186^{1.5}} = 0.088$$

$$(rt_u)^{0.5} = [(42,500)(31.33)]^{0.5} = 1153.9$$

$$\begin{aligned} x_1 &= 0.61(rt_u)^{0.5} + 320CH \\ &= 0.61(1153.9) + 320(0.088)(16.8) = 1177.0 \end{aligned}$$

$$x_2 = 1000CH = 1000(0.088)(16.8) = 1478.4$$

$$x_3 = 1.22(rt_u)^{0.5} = 1.22(1153.9) = 1407.8$$

$$x = \min(x_1, x_2, x_3) = 1177$$

$$x/1000 = 1.177$$

$$t_{tx} = \frac{4.9D(H-x/1000)}{S_t} = \frac{4.9(85)(16.8-1.177)}{208} = 31.28 \text{ mm} = t_{2a}$$

In US Customary units:

$$t_u = t_{tx} \text{ from first trial} = 1.267 \text{ in.}$$

$$t_L = 1.501 \text{ in.}$$

$$K = \frac{t_L}{t_u} = \frac{1.501}{1.267} = 1.185$$

$$K^{0.5} = 1.089$$

$$C = \frac{K^{0.5}(K-1)}{1+K^{1.5}} = \frac{(1.089)(0.185)}{1+1.290} = 0.088$$

$$(rt_u)^{0.5} = [(1680)(1.266)]^{0.5} = 46.12$$

$$\begin{aligned} x_1 &= 0.61(rt_u)^{0.5} + 3.84CH \\ &= 0.61(46.12) + 3.84(0.088)(56) = 28.13 + 18.92 = 47.05 \end{aligned}$$

$$x_2 = 12CH = 59.14$$

$$x_3 = 1.22(rt_u)^{0.5} = 1.22(46.12) = 56.27$$

$$x = \min(x_1, x_2, x_3) = 47.05$$

$$x/12 = 3.92$$

$$t_{tx} = \frac{2.6D(H-x/12)}{S_t} = \frac{2.6(280)(56-3.92)}{30,000} = 1.263 \text{ in.} = t_{2a}$$

Use this value to calculate  $t_2$ .

**K.2.3.2 Course 3**

Note:  $H = 14.4$  m (48 ft).

**K.2.3.2.1 First Trial**

In SI units:

$$t_{tx} = \frac{4.9D(H - 0.3)}{S_t} = \frac{4.9(85)(14.4 - 0.3)}{208}$$

$$= 28.23 \text{ mm} = t_u$$

$$t_L = 34.64 \text{ mm}$$

$$K = \frac{t_L}{t_u} = \frac{34.64}{28.23} = 1.227$$

$$K^{0.5} = 1.108$$

$$C = \frac{K^{0.5}(K - 1)}{1 + K^{0.5}} = \frac{(1.108)(0.227)}{1 + 1.227^{1.5}} = 0.107$$

$$(rt_u)^{0.5} = [(42,500)(28.23)]^{0.5} = 1095$$

$$x_1 = 0.61(rt_u)^{0.5} + 320CH$$

$$= 0.61(1095) + 320(0.107)(14.4) = 1161$$

$$x_2 = 1000CH = 1000(0.107)(14.4) = 1541$$

$$x_3 = 1.22(rt_u)^{0.5} = 1.22(1095) = 1336$$

$$x = \min(x_1, x_2, x_3) = 1161$$

$$x/1000 = 1.161$$

$$t_{tx} = \frac{4.9D(H - x/1000)}{S_t} = \frac{4.9(85)(14.4 - 1.161)}{208} = 26.51 \text{ mm}$$

In US Customary units:

$$t_{tx} = \frac{2.6D(H - 1)}{S_t} = \frac{2.6(280)(47)}{30,000}$$

$$= 1.141 \text{ in.} = t_u$$

$$t_L = 1.399 \text{ in.}$$

$$K = \frac{t_L}{t_u} = \frac{1.399}{1.141} = 1.226$$

$$K^{0.5} = 1.107$$

$$C = \frac{K^{0.5}(K - 1)}{1 + K^{1.5}} = \frac{(1.107)(0.266)}{1 + 1.357} = 0.106$$

$$(rt_u)^{0.5} = [(1680)(1.141)]^{0.5} = 43.78$$

$$x_1 = 0.61(rt_u)^{0.5} + 3.84CH$$

$$= 0.61(43.78) + 3.84(0.106)(48) = 26.71 + 19.54 = 46.25$$

$$x_2 = 12CH = 12(0.106)(48) = 61.06$$

$$x_3 = 1.22(rt_u)^{0.5} = 1.22(43.78) = 53.41$$

$$x = \min(x_1, x_2, x_3) = 46.25$$

$$x/12 = 3.85$$

$$t_{tx} = \frac{2.6D(H - x/12)}{S_t} = \frac{2.6(280)(48 - 3.85)}{30,000} = 1.071 \text{ in.}$$

With this value of  $t_{tx}$ , start the second trial.

**K.2.3.2.2 Second Trial**

In SI units:

$$t_u = t_{tx} \text{ from the first trial} = 26.51 \text{ mm}$$

$$t_L = 34.64 \text{ mm}$$

$$K = \frac{t_L}{t_u} = \frac{34.64}{26.51} = 1.307$$

$$K^{0.5} = 1.143$$

$$C = \frac{K^{0.5}(K-1)}{1+K^{1.5}} = \frac{(1.143)(0.307)}{1+1.307^{1.5}} = 0.141$$

$$(rt_u)^{0.5} = [(42,500)(26.51)]^{0.5} = 1061$$

$$\begin{aligned} x_1 &= 0.61(rt_u)^{0.5} + 320CH \\ &= 0.61(1061) + 320(0.141)(14.4) = 1297 \end{aligned}$$

$$x_2 = 1000CH = 1000(0.141)(14.4) = 2030$$

$$x_3 = 1.22(rt_u)^{0.5} = 1.22(1061) = 1294$$

$$x = \min(x_1, x_2, x_3) = 1294$$

$$x/1000 = 1.294$$

$$t_{tx} = \frac{4.9D(H-x/1000)}{S_t} = \frac{4.9(85)(14.4-1.294)}{208} = 26.24 \text{ mm}$$

In US Customary units:

$$t_u = t_{tx} \text{ from first trial} = 1.071 \text{ in.}$$

$$t_L = 1.399 \text{ in.}$$

$$K = \frac{t_L}{t_u} = \frac{1.399}{1.071} = 1.306$$

$$K^{0.5} = 1.143$$

$$C = \frac{K^{0.5}(K-1)}{1+K^{1.5}} = \frac{(1.143)(0.306)}{1+1.493} = 0.140$$

$$(rt_u)^{0.5} = [(1680)(1.071)]^{0.5} = 42.42$$

$$\begin{aligned} x_1 &= 0.61(rt_u)^{0.5} + 3.84CH \\ &= 0.61(42.42) + 3.84(0.140)(48) = 25.88 + 25.80 = 51.68 \end{aligned}$$

$$x_2 = 12CH = 12(0.140)(48) = 80.64$$

$$x_3 = 1.22(rt_u)^{0.5} = 1.22(42.42) = 51.75$$

$$x = \min(x_1, x_2, x_3) = 51.68$$

$$x/12 = 4.31$$

$$t_{tx} = \frac{2.6D(H-x/12)}{S_t} = \frac{2.6(280)(48-4.31)}{30,000} = 1.060 \text{ in.}$$

With this value of  $t_{tx}$ , start the third trial.

**K.2.3.2.3 Third Trial**

In SI units:

$$t_u = t_{tx} \text{ from the second trial} = 26.24 \text{ mm}$$

$$t_L = 34.64 \text{ mm}$$

$$K = \frac{t_L}{t_u} = \frac{34.64}{26.24} = 1.320$$

$$K^{0.5} = 1.149$$

$$C = \frac{K^{0.5}(K-1)}{1+K^{1.5}} = \frac{(1.149)(0.320)}{1+1.320^{1.5}} = 0.146$$

$$(rt_u)^{0.5} = [(42,500)(26.24)]^{0.5} = 1056$$

$$\begin{aligned} x_1 &= 0.61(rt_u)^{0.5} + 320CH \\ &= 0.61(1056) + 320(0.146)(14.4) = 1317 \end{aligned}$$

$$x_2 = 1000CH = 1000(0.146)(14.4) = 2102$$

$$x_3 = 1.22(rt_u)^{0.5} = 1.22(1056) = 1288$$

$$x = \min(x_1, x_2, x_3) = 1288$$

$$x/1000 = 1.288$$

$$t_{tx} = \frac{4.9D(H-x/1000)}{S_t} = \frac{4.9(85)(14.4-1.288)}{208} = 26.26 \text{ mm for Course 3}$$

In US Customary units:

$$t_u = t_{tx} \text{ from second trial} = 1.060 \text{ in.}$$

$$t_L = 1.399 \text{ in.}$$

$$K = \frac{t_L}{t_u} = \frac{1.399}{1.060} = 1.320$$

$$K^{0.5} = 1.149$$

$$C = \frac{K^{0.5}(K-1)}{1+K^{1.5}} = \frac{(1.149)(0.320)}{1+1.517} = 0.146$$

$$(rt_u)^{0.5} = [(1680)(1.06)]^{0.5} = 42.20$$

$$\begin{aligned} x_1 &= 0.61(rt_u)^{0.5} + 3.84CH \\ &= 0.61(42.40) + 3.84(0.146)(48) = 25.74 + 26.91 = 52.65 \end{aligned}$$

$$x_2 = 12CH = 12(0.146)(48) = 84.10$$

$$x_3 = 1.22(rt_u)^{0.5} = 1.22(42.20) = 51.48$$

$$x = \min(x_1, x_2, x_3) = 51.48$$

$$x/12 = 4.29$$

$$t_{tx} = \frac{2.6D(H-x/12)}{S_t} = \frac{2.6(280)(48-4.29)}{30,000} = 1.061 \text{ in. for Course 3}$$

(Sample calculated shell-plate thicknesses for various tank sizes and allowable stresses are given in Tables K-1 through K-3.)

Table K-1—Shell-Plate Thicknesses Based on the Variable-Design-Point Method (See 3.6.4) Using 2400 mm (96 in.) Courses and an Allowable Stress of 159 MPa (23,000 lbf/in.<sup>2</sup>) for the Test Condition

Tank Height m (ft)	Tank Diameter m (ft)	Weight of Shell Mg (tons)	Shell Plate Thickness for Course, mm (in.)								Nominal Tank Volume m <sup>3</sup> (bbl)	
			1	2	3	4	5	6	7	8		
12 (40)	60 (200)	233 (272)	21.40 (0.871)	16.18 (0.659)	11.96 (0.487)	8.00 (0.317)	8.00 (0.313)	—	—	—	—	33,900 (224,000)
	65 (220)	282 (333)	22.99 (0.949)	17.42 (0.720)	12.90 (0.533)	10.00 (0.375)	10.00 (0.375)	—	—	—	—	39,800 (271,000)
	75 (240)	363 (389)	26.09 (1.025)	20.95 (0.807)	14.58 (0.574)	10.00 (0.375)	10.00 (0.375)	—	—	—	—	53,000 (322,500)
	80 (260)	408 (453)	27.59 (1.099)	22.97 (0.907)	15.39 (0.613)	10.02 (0.398)	10.00 (0.375)	—	—	—	—	60,300 (378,500)
	85 (280)	457 (522)	29.06 (1.171)	24.95 (1.004)	16.21 (0.653)	10.59 (0.427)	10.00 (0.375)	—	—	—	—	68,100 (439,000)
	90 (300)	510 (594)	30.51 (1.241)	26.88 (1.098)	17.01 (0.692)	11.16 (0.454)	10.00 (0.375)	—	—	—	—	76,300 (504,000)
	100 (320)	621 (671)	33.31 (1.310)	30.59 (1.189)	18.57 (0.730)	12.28 (0.482)	10.00 (0.375)	—	—	—	—	94,200 (573,400)
	105 (340)	680 (751)	34.66 (1.377)	32.40 (1.277)	19.32 (0.768)	12.84 (0.509)	10.00 (0.375)	—	—	—	—	103,900 (647,300)
	110 (360)	741 (835)	35.99 (1.433)	34.21 (1.362)	20.06 (0.804)	13.39 (0.536)	10.00 (0.375)	—	—	—	—	114,000 (725,700)
	115 (380)	804 (923)	37.29 (1.506)	35.94 (1.448)	20.78 (0.840)	13.93 (0.562)	10.00 (0.375)	—	—	—	—	124,600 (808,600)
14.4 (48)	55 (180)	276 (312)	23.90 (0.956)	18.85 (0.755)	14.99 (0.600)	11.06 (0.443)	8.00 (0.313)	8.00 (0.313)	—	—	—	34,200 (217,700)
	60 (200)	322 (376)	25.90 (1.055)	20.43 (0.832)	16.29 (0.664)	11.96 (0.487)	8.00 (0.317)	8.00 (0.313)	—	—	—	40,700 (268,800)
	65 (220)	388 (463)	27.85 (1.150)	22.54 (0.943)	17.49 (0.721)	12.89 (0.533)	10.00 (0.375)	10.00 (0.375)	—	—	—	47,800 (325,200)
	75 (240)	505 (543)	31.65 (1.243)	27.47 (1.063)	19.76 (0.776)	14.78 (0.579)	10.00 (0.375)	10.00 (0.375)	—	—	—	63,600 (387,000)
	80 (260)	569 (633)	33.50 (1.334)	29.85 (1.181)	20.92 (0.833)	15.71 (0.625)	10.00 (0.397)	10.00 (0.375)	—	—	—	72,400 (454,200)
	85 (280)	638 (729)	35.32 (1.423)	32.17 (1.295)	22.05 (0.889)	16.63 (0.669)	10.53 (0.424)	10.00 (0.375)	—	—	—	81,700 (526,800)
	90 (298)	711 (821)	37.11 (1.502)	34.44 (1.394)	23.17 (0.938)	17.54 (0.710)	11.08 (0.448)	10.00 (0.375)	—	—	—	91,600 (596,700)
16.8 (56)	50 (160)	306 (333)	25.42 (0.995)	20.83 (0.817)	17.30 (0.678)	13.69 (0.537)	10.15 (0.398)	8.00 (0.313)	8.00 (0.313)	—	—	33,000 (200,700)
	55 (180)	364 (412)	27.97 (1.119)	22.77 (0.912)	18.98 (0.760)	14.96 (0.599)	11.06 (0.443)	8.00 (0.313)	8.00 (0.313)	—	—	39,900 (254,000)
	60 (200)	428 (502)	30.42 (1.239)	25.25 (1.033)	20.54 (0.836)	16.27 (0.663)	11.96 (0.487)	8.00 (0.317)	8.00 (0.313)	—	—	47,500 (313,600)
	65 (220)	514 (615)	32.73 (1.351)	28.17 (1.175)	22.02 (0.908)	17.59 (0.727)	12.89 (0.532)	10.00 (0.375)	10.00 (0.375)	—	—	55,700 (379,400)
	75 (240)	671 (723)	37.24 (1.462)	33.81 (1.313)	25.01 (0.982)	20.17 (0.790)	14.72 (0.577)	10.00 (0.375)	10.00 (0.375)	—	—	74,200 (451,500)
	77 (247)	705 (764)	38.12 (1.500)	34.91 (1.361)	25.60 (1.007)	20.69 (0.812)	15.09 (0.592)	10.00 (0.379)	10.00 (0.375)	—	—	78,200 (478,300)
19.2 (64)	50 (160)	390 (423)	29.12 (1.139)	24.42 (0.957)	20.95 (0.820)	17.28 (0.677)	13.69 (0.537)	10.15 (0.398)	8.00 (0.313)	8.00 (0.313)	—	37,700 (229,300)
	55 (180)	466 (527)	32.03 (1.282)	27.03 (1.078)	22.92 (0.918)	18.95 (0.758)	14.98 (0.599)	11.06 (0.443)	8.00 (0.313)	8.00 (0.313)	—	45,600 (290,300)
	60 (200)	551 (646)	34.95 (1.423)	30.39 (1.242)	24.75 (1.007)	20.63 (0.841)	16.27 (0.662)	11.96 (0.487)	8.00 (0.317)	8.00 (0.313)	—	54,300 (358,400)
	62.5 (212)	610 (735)	36.29 (1.502)	32.04 (1.338)	25.66 (1.061)	21.47 (0.890)	16.91 (0.700)	12.41 (0.514)	10.00 (0.375)	10.00 (0.375)	—	58,900 (402,600)

Table K-2—Shell-Plate Thicknesses Based on the Variable-Design-Point Method (See 3.6.4)  
Using 2400 mm (96 in.) Courses and an Allowable Stress of 208 MPa (30,000 lbf/in.<sup>2</sup>) for the Test Condition

Tank Height m (ft)	Tank Diameter m (ft)	Weight of Shell Mg (tons)	Shell Plate Thickness for Course, mm (in.)								Nominal Tank Volume m <sup>3</sup> (bbl)	
			1	2	3	4	5	6	7	8		
12 (40)	75 (240)	298 (320)	20.26 (0.798)	15.36 (0.603)	11.38 (0.447)	10.00 (0.375)	10.00 (0.375)	10.00 (0.375)	—	—	—	53,000 (322,500)
	80 (260)	332 (365)	21.45 (0.856)	16.48 (0.651)	12.06 (0.482)	10.00 (0.375)	10.00 (0.375)	10.00 (0.375)	—	—	—	60,300 (378,500)
	85 (280)	369 (417)	22.63 (0.914)	18.07 (0.729)	12.65 (0.511)	10.00 (0.375)	10.00 (0.375)	10.00 (0.375)	—	—	—	68,100 (439,000)
	90 (300)	409 (472)	23.78 (0.971)	19.63 (0.806)	13.27 (0.541)	10.00 (0.375)	10.00 (0.375)	10.00 (0.375)	—	—	—	76,300 (504,000)
	100 (320)	493 (530)	26.03 (1.026)	22.64 (0.880)	14.51 (0.572)	10.00 (0.375)	10.00 (0.375)	10.00 (0.375)	—	—	—	94,200 (573,400)
	105 (340)	537 (594)	27.12 (1.080)	24.10 (0.952)	15.12 (0.602)	10.00 (0.395)	10.00 (0.375)	10.00 (0.375)	—	—	—	103,900 (647,300)
	110 (360)	585 (661)	28.20 (1.133)	25.52 (1.022)	15.72 (0.632)	10.37 (0.416)	10.00 (0.375)	10.00 (0.375)	—	—	—	114,000 (725,700)
	115 (380)	636 (731)	29.25 (1.185)	26.92 (1.090)	16.31 (0.660)	10.79 (0.437)	10.00 (0.375)	10.00 (0.375)	—	—	—	124,600 (800,600)
	120 (400)	688 (803)	30.29 (1.235)	28.30 (1.156)	16.88 (0.689)	11.22 (0.458)	10.00 (0.375)	10.00 (0.375)	—	—	—	135,700 (896,000)
14.4 (48)	65 (220)	316 (374)	21.55 (0.892)	16.99 (0.704)	13.52 (0.561)	10.00 (0.412)	10.00 (0.375)	10.00 (0.375)	10.00 (0.375)	—	—	47,800 (325,200)
	75 (240)	406 (436)	24.54 (0.966)	19.96 (0.773)	15.41 (0.608)	11.37 (0.446)	10.00 (0.375)	10.00 (0.375)	10.00 (0.375)	—	—	63,600 (387,000)
	80 (260)	456 (505)	26.01 (1.038)	21.86 (0.866)	16.27 (0.650)	12.09 (0.482)	10.00 (0.375)	10.00 (0.375)	10.00 (0.375)	—	—	72,400 (454,200)
	85 (280)	509 (579)	27.45 (1.109)	23.73 (0.958)	17.14 (0.692)	12.81 (0.517)	10.00 (0.375)	10.00 (0.375)	10.00 (0.375)	—	—	81,700 (526,800)
	90 (300)	565 (656)	28.87 (1.178)	25.55 (1.047)	18.02 (0.736)	13.52 (0.552)	10.00 (0.375)	10.00 (0.375)	10.00 (0.375)	—	—	91,600 (604,800)
	100 (320)	684 (739)	31.64 (1.247)	29.10 (1.135)	19.76 (0.778)	14.92 (0.587)	10.00 (0.375)	10.00 (0.375)	10.00 (0.375)	—	—	113,100 (688,100)
	105 (340)	747 (827)	33.00 (1.314)	30.81 (1.220)	20.61 (0.820)	15.62 (0.621)	10.00 (0.392)	10.00 (0.375)	10.00 (0.375)	—	—	124,700 (776,800)
	110 (360)	814 (921)	34.33 (1.379)	32.49 (1.302)	21.44 (0.862)	16.31 (0.655)	10.00 (0.375)	10.00 (0.375)	10.00 (0.375)	—	—	136,800 (870,900)
	115 (380)	885 (1019)	35.65 (1.444)	34.18 (1.383)	22.26 (0.902)	17.01 (0.688)	10.68 (0.433)	10.00 (0.375)	10.00 (0.375)	—	—	149,600 (970,300)
	120 (400)	958 (1121)	36.94 (1.507)	35.83 (1.462)	23.08 (0.942)	17.73 (0.721)	11.08 (0.452)	10.00 (0.375)	10.00 (0.375)	—	—	162,900 (1,075,200)
16.8 (56)	60 (200)	341 (400)	23.32 (0.953)	19.05 (0.778)	15.85 (0.648)	12.51 (0.511)	8.00 (0.313)	9.27 (0.378)	8.00 (0.313)	8.00 (0.313)	—	47,500 (313,600)
	65 (220)	410 (490)	25.27 (1.048)	20.53 (0.858)	17.13 (0.709)	13.50 (0.560)	10.00 (0.412)	10.00 (0.375)	10.00 (0.375)	10.00 (0.375)	—	55,700 (379,400)
	75 (240)	533 (575)	28.84 (1.135)	24.92 (0.968)	19.40 (0.764)	15.51 (0.609)	11.36 (0.446)	10.00 (0.375)	10.00 (0.375)	10.00 (0.375)	—	74,200 (451,500)
	80 (260)	601 (668)	30.58 (1.220)	27.09 (1.075)	20.53 (0.819)	16.50 (0.658)	12.07 (0.481)	10.00 (0.375)	10.00 (0.375)	10.00 (0.375)	—	84,400 (529,900)
	85 (280)	672 (766)	32.29 (1.305)	29.23 (1.180)	21.68 (0.876)	17.48 (0.706)	12.76 (0.515)	10.00 (0.375)	10.00 (0.375)	10.00 (0.375)	—	95,300 (614,600)
	90 (300)	747 (871)	33.98 (1.387)	31.33 (1.283)	22.82 (0.932)	18.46 (0.754)	13.46 (0.549)	10.00 (0.375)	10.00 (0.375)	10.00 (0.375)	—	106,900 (705,600)
	100 (320)	907 (981)	37.29 (1.469)	35.41 (1.383)	25.05 (0.987)	20.42 (0.801)	14.82 (0.583)	10.00 (0.375)	10.00 (0.375)	10.00 (0.375)	—	131,900 (802,800)
	105 (340)	992 (1100)	38.91 (1.549)	37.39 (1.481)	26.14 (1.041)	21.46 (0.849)	15.48 (0.616)	10.00 (0.393)	10.00 (0.375)	10.00 (0.375)	—	145,500 (906,300)
	110 (360)	1083 (1225)	40.51 (1.627)	39.36 (1.577)	27.23 (1.094)	22.64 (0.895)	16.11 (0.649)	10.30 (0.413)	10.00 (0.375)	10.00 (0.375)	—	159,700 (1,016,000)
	115 (380)	1179 (1358)	42.08 (1.705)	41.28 (1.671)	28.33 (1.148)	23.79 (0.951)	16.74 (0.679)	10.72 (0.434)	10.00 (0.375)	10.00 (0.375)	—	174,500 (1,132,000)
	120 (392)	1278 (1441)	43.63 (1.750)	43.14 (1.726)	29.44 (1.180)	24.94 (0.986)	17.36 (0.698)	11.14 (0.446)	10.00 (0.375)	10.00 (0.375)	—	190,000 (1,204,700)
19.2 (64)	60 (200)	433 (508)	26.71 (1.092)	22.34 (0.913)	19.19 (0.784)	15.83 (0.647)	12.52 (0.511)	9.27 (0.378)	8.00 (0.313)	8.00 (0.313)	—	54,300 (358,400)
	65 (220)	520 (623)	28.94 (1.201)	24.70 (1.034)	20.63 (0.853)	17.11 (0.710)	13.51 (0.560)	10.00 (0.412)	10.00 (0.375)	10.00 (0.375)	—	63,700 (433,600)
	75 (240)	679 (734)	33.16 (1.304)	29.77 (1.159)	23.42 (0.922)	19.67 (0.772)	15.47 (0.608)	11.36 (0.447)	10.00 (0.375)	10.00 (0.375)	—	84,800 (516,000)
	80 (260)	766 (853)	35.17 (1.403)	32.22 (1.280)	24.85 (0.992)	20.93 (0.834)	16.45 (0.655)	12.06 (0.481)	10.00 (0.375)	10.00 (0.375)	—	96,500 (605,600)
	85 (280)	858 (981)	37.15 (1.501)	34.64 (1.399)	26.25 (1.061)	22.18 (0.896)	17.41 (0.703)	12.77 (0.516)	10.00 (0.375)	10.00 (0.375)	—	109,000 (702,400)
	90 (300)	955 (1116)	39.12 (1.597)	37.01 (1.515)	27.65 (1.129)	23.44 (0.957)	18.36 (0.749)	13.46 (0.550)	10.00 (0.375)	10.00 (0.375)	—	122,100 (806,400)
	100 (320)	1163 (1259)	42.96 (1.692)	41.63 (1.629)	30.38 (1.196)	26.27 (1.017)	20.19 (0.796)	14.85 (0.584)	10.00 (0.375)	10.00 (0.375)	—	150,800 (917,500)
	101 (332)	1185 (1350)	43.34 (1.748)	42.08 (1.696)	30.65 (1.236)	26.56 (1.059)	20.37 (0.822)	14.98 (0.604)	10.00 (0.375)	10.00 (0.375)	—	153,800 (987,600)

Table K-3—Shell-Plate Thicknesses Based on the Variable-Design-Point Method (See 3.6.4) Using 2400 mm (96 in.) Courses and an Allowable Stress of 236 MPa (34,300 lbf/in.<sup>2</sup>) for the Test Condition

Tank Height m (ft)	Tank Diameter m (ft)	Weight of Shell Mg (tons)	Shell Plate Thickness for Course, mm (in.)								Nominal Tank Volume m <sup>3</sup> (bbl)	
			1	2	3	4	5	6	7	8		
14.4 (48)	65 (220)	293 (341)	19.03 (0.784)	15.04 (0.619)	11.95 (0.492)	10.00 (0.375)	10.00 (0.375)	10.00 (0.375)	10.00 (0.375)	10.00 (0.375)	10.00 (0.375)	47,800 (325,200)
	75 (240)	368 (394)	21.76 (0.850)	17.19 (0.670)	13.70 (0.534)	10.05 (0.393)	10.00 (0.375)	10.00 (0.375)	10.00 (0.375)	10.00 (0.375)	10.00 (0.375)	63,600 (387,000)
	80 (260)	413 (453)	23.07 (0.914)	18.78 (0.736)	14.48 (0.574)	10.69 (0.423)	10.00 (0.375)	10.00 (0.375)	10.00 (0.375)	10.00 (0.375)	10.00 (0.375)	72,400 (454,200)
	85 (280)	460 (519)	24.36 (0.977)	20.45 (0.818)	15.24 (0.611)	11.33 (0.454)	10.00 (0.375)	10.00 (0.375)	10.00 (0.375)	10.00 (0.375)	10.00 (0.375)	81,700 (526,800)
	90 (300)	510 (588)	25.63 (1.039)	22.10 (0.898)	16.00 (0.649)	11.96 (0.485)	10.00 (0.375)	10.00 (0.375)	10.00 (0.375)	10.00 (0.375)	10.00 (0.375)	91,600 (604,800)
	100 (320)	617 (662)	28.12 (1.100)	25.30 (0.977)	17.56 (0.687)	13.21 (0.515)	10.00 (0.375)	10.00 (0.375)	10.00 (0.375)	10.00 (0.375)	10.00 (0.375)	113,100 (688,100)
	105 (340)	674 (738)	29.34 (1.160)	26.85 (1.053)	18.32 (0.724)	13.82 (0.545)	10.00 (0.375)	10.00 (0.375)	10.00 (0.375)	10.00 (0.375)	10.00 (0.375)	124,700 (776,800)
	110 (360)	733 (819)	30.54 (1.218)	28.37 (1.127)	19.07 (0.761)	14.44 (0.575)	10.00 (0.375)	10.00 (0.375)	10.00 (0.375)	10.00 (0.375)	10.00 (0.375)	136,800 (870,900)
	115 (380)	794 (904)	31.73 (1.276)	29.87 (1.200)	19.81 (0.797)	15.05 (0.605)	10.00 (0.381)	10.00 (0.375)	10.00 (0.375)	10.00 (0.375)	10.00 (0.375)	149,600 (970,300)
	120 (400)	856 (994)	32.89 (1.333)	31.34 (1.271)	20.54 (0.832)	15.66 (0.634)	10.00 (0.399)	10.00 (0.375)	10.00 (0.375)	10.00 (0.375)	10.00 (0.375)	162,900 (1,075,200)
16.8 (56)	60 (200)	308 (358)	20.56 (0.834)	16.86 (0.684)	14.00 (0.568)	11.08 (0.449)	8.21 (0.333)	8.21 (0.333)	8.21 (0.333)	8.00 (0.313)	8.00 (0.313)	47,500 (313,600)
	65 (220)	376 (441)	22.27 (0.917)	18.17 (0.747)	15.13 (0.623)	11.93 (0.491)	10.00 (0.375)	10.00 (0.375)	10.00 (0.375)	10.00 (0.375)	10.00 (0.375)	55,700 (379,400)
	75 (240)	480 (514)	25.56 (0.998)	21.48 (0.825)	17.24 (0.674)	13.70 (0.534)	10.05 (0.393)	10.05 (0.393)	10.05 (0.393)	10.00 (0.375)	10.00 (0.375)	74,200 (451,500)
	80 (260)	541 (596)	27.11 (1.074)	23.43 (0.921)	18.23 (0.723)	14.58 (0.577)	10.67 (0.422)	10.67 (0.422)	10.67 (0.422)	10.00 (0.375)	10.00 (0.375)	84,400 (529,900)
	85 (280)	604 (684)	28.64 (1.149)	25.35 (1.015)	19.23 (0.771)	15.45 (0.620)	11.29 (0.453)	11.29 (0.453)	11.29 (0.453)	10.00 (0.375)	10.00 (0.375)	95,300 (614,600)
	90 (300)	671 (777)	30.15 (1.222)	27.24 (1.107)	20.25 (0.821)	16.32 (0.662)	11.91 (0.483)	11.91 (0.483)	11.91 (0.483)	10.00 (0.375)	10.00 (0.375)	106,900 (705,600)
	100 (320)	815 (875)	33.12 (1.295)	30.92 (1.197)	22.24 (0.869)	18.04 (0.703)	13.12 (0.512)	13.12 (0.512)	13.12 (0.512)	10.00 (0.375)	10.00 (0.375)	131,900 (802,800)
	105 (340)	891 (978)	34.57 (1.366)	32.70 (1.284)	23.22 (0.918)	18.90 (0.745)	13.72 (0.542)	13.72 (0.542)	13.72 (0.542)	10.00 (0.375)	10.00 (0.375)	145,500 (906,300)
	110 (360)	970 (1086)	36.01 (1.436)	34.46 (1.370)	24.19 (0.965)	19.77 (0.786)	14.31 (0.571)	14.31 (0.571)	14.31 (0.571)	10.00 (0.375)	10.00 (0.375)	159,700 (1,016,000)
	115 (380)	1053 (1200)	37.42 (1.505)	36.19 (1.454)	25.15 (1.012)	20.80 (0.827)	14.87 (0.600)	14.87 (0.600)	14.87 (0.600)	10.00 (0.382)	10.00 (0.375)	174,500 (1,132,000)
	120 (400)	1139 (1322)	38.82 (1.573)	37.92 (1.536)	26.11 (1.058)	21.83 (0.873)	15.43 (0.627)	15.43 (0.627)	15.43 (0.627)	10.00 (0.400)	10.00 (0.375)	190,000 (1,254,400)
19.2 (64)	60 (200)	389 (453)	23.54 (0.955)	19.76 (0.801)	16.94 (0.687)	13.98 (0.567)	11.08 (0.449)	11.08 (0.449)	11.08 (0.449)	8.21 (0.333)	8.00 (0.313)	54,300 (358,400)
	65 (220)	471 (556)	25.51 (1.051)	21.32 (0.884)	18.31 (0.752)	15.10 (0.622)	11.94 (0.491)	11.94 (0.491)	11.94 (0.491)	10.00 (0.375)	10.00 (0.375)	63,700 (433,600)
	75 (240)	609 (653)	29.37 (1.146)	25.79 (0.994)	20.78 (0.812)	17.37 (0.677)	13.67 (0.533)	13.67 (0.533)	13.67 (0.533)	10.05 (0.393)	10.00 (0.375)	84,800 (516,000)
	80 (260)	687 (759)	31.17 (1.235)	27.99 (1.102)	22.02 (0.872)	18.49 (0.731)	14.53 (0.575)	14.53 (0.575)	14.53 (0.575)	10.68 (0.423)	10.00 (0.375)	96,500 (605,600)
	85 (280)	769 (872)	32.94 (1.321)	30.16 (1.208)	23.27 (0.933)	19.60 (0.786)	15.39 (0.617)	15.39 (0.617)	15.39 (0.617)	11.30 (0.453)	10.00 (0.375)	109,000 (702,400)
	90 (300)	855 (992)	34.69 (1.406)	32.29 (1.311)	24.51 (0.994)	20.70 (0.839)	16.24 (0.658)	16.24 (0.658)	16.24 (0.658)	11.92 (0.483)	10.00 (0.375)	122,100 (806,400)
	100 (320)	1041 (1119)	38.13 (1.490)	36.45 (1.413)	26.96 (1.053)	22.99 (0.893)	17.90 (0.699)	17.90 (0.699)	17.90 (0.699)	13.15 (0.513)	10.00 (0.375)	150,800 (917,500)
	105 (340)	1140 (1252)	39.82 (1.573)	38.47 (1.512)	28.16 (1.112)	24.27 (0.946)	18.70 (0.740)	18.70 (0.740)	18.70 (0.740)	13.76 (0.543)	10.00 (0.375)	166,300 (1,035,700)
	110 (360)	1243 (1394)	41.49 (1.655)	40.47 (1.610)	29.34 (1.170)	25.57 (1.007)	19.49 (0.779)	19.49 (0.779)	19.49 (0.779)	14.36 (0.572)	10.00 (0.375)	182,500 (1,161,200)
	115 (380)	1351 (1543)	43.14 (1.735)	42.45 (1.705)	30.55 (1.228)	26.85 (1.071)	20.27 (0.817)	20.27 (0.817)	20.27 (0.817)	14.97 (0.601)	10.00 (0.375)	199,400 (1,293,800)
	117 (384)	1395 (1574)	43.80 <sup>a</sup> (1.751 <sup>a</sup> )	43.22 (1.724)	31.03 (1.240)	27.36 (1.083)	20.59 (0.824)	20.59 (0.824)	20.59 (0.824)	15.21 (0.607)	10.00 (0.375)	206,400 (1,321,200)

<sup>a</sup>Exceeds maximum allowed material thickness.



## APPENDIX L— API STANDARD 650 STORAGE TANK DATA SHEETS

The following data sheets shall be used by the purchaser when ordering and by the manufacturer when bidding on a storage tank constructed in accordance with this standard. However, the purchaser and manufacturer may use data sheets other than that provided in this Appendix, if they include all pertinent information.

The conditions that must be met are set forth in a convenient form and can be noted either by inserting information in the spaces provided or by checking the appropriate answer where a selection is indicated.

Space is provided where computations or fabrication practices may dictate a size or dimension of the tank or its components. Further information concerning appurtenances or accessories shall be included.

Any materials that either have received any heat treatment, such as normalizing, beyond the minimum heat-treating requirements of the material specification or have been qualified by impact tests shall be identified by reference to notes located under the “remarks” lines. The notes shall define the heat treatment received and/or the energy acceptance levels, test temperature, and specimen orientation for impact tests.

When stress relief is applied to a part in accordance with the requirements of 3.7.4, the part shall be identified by a note under the “remarks” lines.

These data sheets do not cover items of a contractual nature or optional features not covered by this standard.

Upon completion of construction, the manufacturer shall furnish the purchaser with a copy of the data sheets corrected to reflect the as-built conditions.





# API STANDARD 650 STORAGE TANK DATA SHEET

DATE \_\_\_\_\_  
 BY \_\_\_\_\_  
 FILE NO. \_\_\_\_\_  
 PAGE 2 OF 4

00

## CONSTRUCTION DETAILS (TO BE COMPLETED BY MANUFACTURER AND/OR PURCHASER)

1. MANUFACTURER \_\_\_\_\_  
 ADDRESS \_\_\_\_\_  
 CITY \_\_\_\_\_ STATE \_\_\_\_\_ ZIP CODE \_\_\_\_\_ PHONE \_\_\_\_\_  
 SERIAL NO. \_\_\_\_\_

1. FABRICATOR \_\_\_\_\_  
 ADDRESS \_\_\_\_\_  
 CITY \_\_\_\_\_ STATE \_\_\_\_\_ ZIP CODE \_\_\_\_\_ PHONE \_\_\_\_\_  
 SERIAL NO. \_\_\_\_\_

3. MATERIAL SPECIFICATIONS: SHELL \_\_\_\_\_  
 ROOF \_\_\_\_\_  
 BOTTOM \_\_\_\_\_  
 STRUCTURALS \_\_\_\_\_

4. NO. OF SHELL COURSES \_\_\_\_\_

5. PLATE WIDTHS AND THICKNESSES (INCLUDING CORROSION ALLOWANCE), IN mm (in.)

1 _____	4 _____	7 _____
2 _____	5 _____	8 _____
3 _____	6 _____	9 _____

6. TANK BOTTOM: PLATE THICKNESS \_\_\_\_\_ mm (in.)  LAP  BUTT SEAMS  
 SLOPE \_\_\_\_\_ mm/m (in/ft)  TO  FROM CENTER

7. MINIMUM WIDTH AND THICKNESS OF BOTTOM ANNULAR PLATES (3.5), IN mm (in.): \_\_\_\_\_

8. ROOF-TO-SHELL DETAIL (FIGURE F-1) \_\_\_\_\_

9. INTERMEDIATE WIND GIRDER?  YES  NO TOP WIND GIRDER FOR USE AS WALKWAY?  YES  NO

10. ROOF TYPE:  SUPPORTED  SELF-SUPPORTED  FLOATING  
 SLOPE OR RADIUS \_\_\_\_\_ mm (in.)

11. ROOF PLATE: THICKNESS \_\_\_\_\_ mm (in.)  LAP  BUTT  JOINT

12. PAINT:

SHELL—	EXTERIOR? <input type="checkbox"/> YES <input type="checkbox"/> NO	INTERIOR? <input type="checkbox"/> YES <input type="checkbox"/> NO
	SURFACE PREPARATION _____	
BOTTOM—	UNDERSIDE? <input type="checkbox"/> YES <input type="checkbox"/> NO	INTERIOR? <input type="checkbox"/> YES <input type="checkbox"/> NO
	SURFACE PREPARATION _____	
STRUCTURAL STEEL—	EXTERIOR? <input type="checkbox"/> YES <input type="checkbox"/> NO	INTERIOR? <input type="checkbox"/> YES <input type="checkbox"/> NO
	SPECIFICATION _____	

13. TANK BOTTOM COATING: INTERIOR?  YES  NO MATERIAL \_\_\_\_\_  
 APPLICATION SPECIFICATION \_\_\_\_\_

14. INSPECTION BY: SHOP \_\_\_\_\_ FIELD \_\_\_\_\_

15. WELD EXAMINATION: RADIOGRAPH \_\_\_\_\_  
 SUPPLEMENTARY LIQUID PENETRANT OR ULTRASONIC \_\_\_\_\_

16. FILMS \_\_\_\_\_ PROPERTY OF \_\_\_\_\_

17. LEAK TESTING: BOTTOM \_\_\_\_\_ ROOF \_\_\_\_\_  
 SHELL \_\_\_\_\_

18. MILL TEST REPORTS: REQUIRED?  YES  NO  
 PLATE \_\_\_\_\_ STRUCTURAL SHAPES \_\_\_\_\_

19. PURCHASER'S REFERENCE DRAWING \_\_\_\_\_

20. TANK SIZE: DIAMETER \_\_\_\_\_ m (ft) HEIGHT \_\_\_\_\_ m (ft)

21. DATE OF STANDARD 650 EDITION/REVISION \_\_\_\_\_

REMARKS \_\_\_\_\_  
 \_\_\_\_\_  
 \_\_\_\_\_  
 \_\_\_\_\_



**API STANDARD 650  
STORAGE TANK  
DATA SHEET**

DATE \_\_\_\_\_  
 BY \_\_\_\_\_  
 FILE NO. \_\_\_\_\_  
 PAGE 4 OF 4

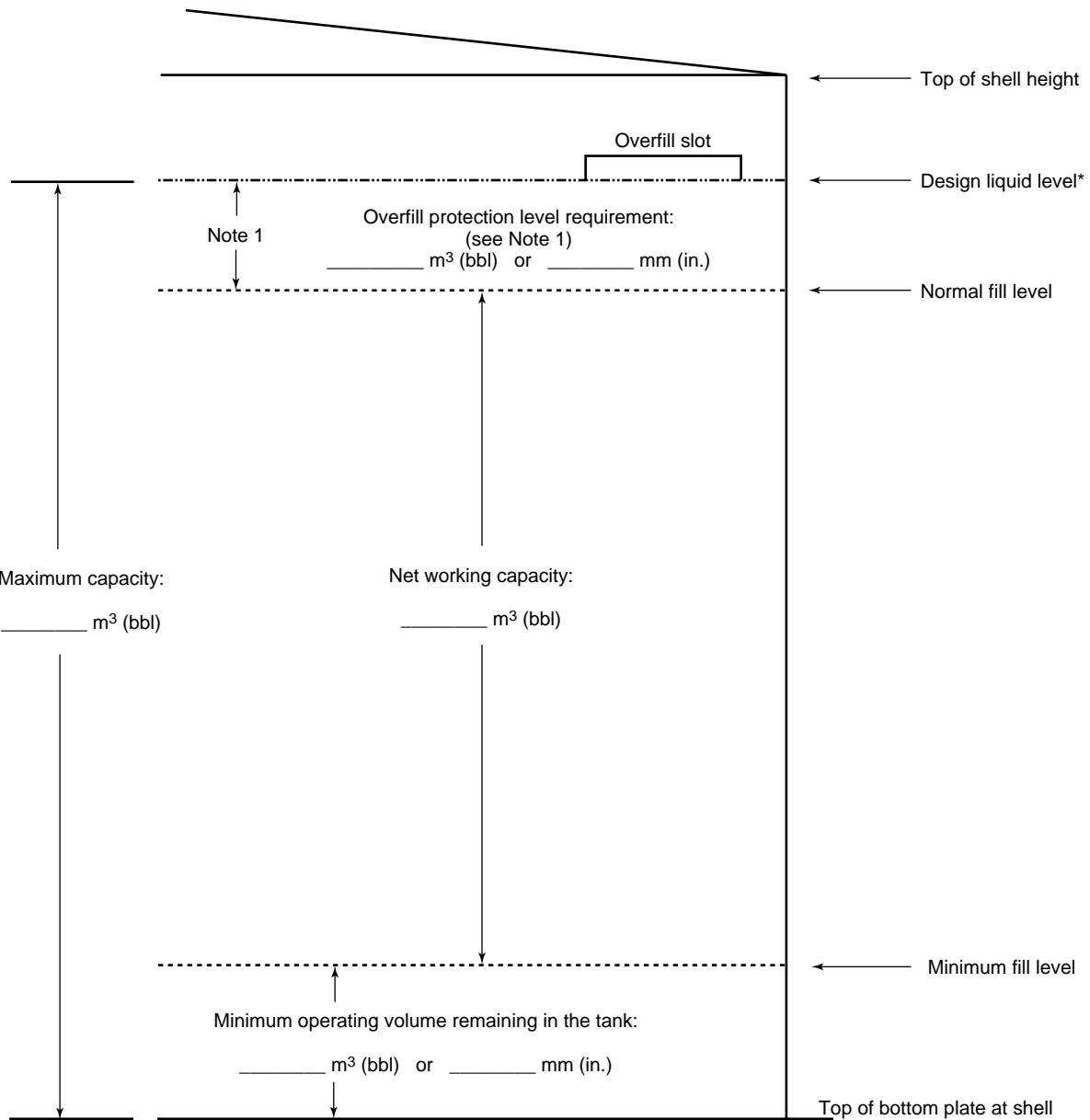

Notes:  
 1. Overfill protection level (or Volume) requirement; see API 2350.  
 \*See 3.6.3.2.

**TABLE L-1—INDEX OF DECISIONS OR ACTIONS WHICH  
MAY BE REQUIRED OF THE PURCHASER**

1.1.9	3.9.6.1 Note	E.1	H.5.2.2
1.1.13	3.9.7.1 Notes A & D	E.3.1 Z, I, W <sub>r</sub>	H.5.2.2.3
1.1.19	3.9.7.6	E.3.2.1 W <sub>t</sub>	H.5.3.1
1.1.20	3.9.7.7	E.3.3.3	H.5.3.2
Table 1-1 App. E, I, O, & P	3.10.2.2	E.4.1 G	H.5.3.3
1.3	3.10.2.4	E.5.3 G	H.5.5.3
2.1.1	3.10.2.5.3	E.6.2.6	H.5.6
2.1.2	3.10.2.7	E.6.2.7	H.5.7
2.1.3.b & c	3.10.2.8	E.8.1	H.5.8
2.2.1.3	3.10.3.1	E.8.2	H.6.1
Table 2-1, Note 1	3.10.4.1	F.1.2	H.6.2
2.2.5	3.10.4.4	F.7.4	H.6.4
Table 2-2, Note C	3.10.4.5	G.1.3.1	H.6.4.1
2.2.6.3	3.10.5	G.1.3.2	H.6.4.2
2.2.7.1	3.10.6	G.1.3.3	H.6.4.3
2.2.7.2	3.11.1	G.1.4.1	I.1.2
2.2.7.3	4.1.1.1	G.1.4.2	I.1.3
2.2.7.4	4.1.2	G.2.1	I.5.5
2.2.8.1	4.2.1	G.2.4	I.6.2
2.2.9.2	5.1.1	G.4.2.2.1	I.6.3
2.2.10.4	5.1.4	G.4.2.3.1	I.6.4
2.3	5.2.1.1	G.4.2.3.2	I.7.1
2.4.1.f	5.2.1.7	G.4.2.5	I.7.3.2
2.4.2	5.2.3.3	G.4.3	I.7.6
2.6.2	5.2.4.1	G.5.3	J.1.2
2.7	5.2.4.2	G.6.2	J.3.2.1
3.1.5.8.b	5.3.2.3	G.7	J.3.6.2
3.1.5.9.e	5.3.5	G.8.1	J.3.7.1
3.2.1	5.3.6.2	G.8.4.1	J.3.7.2
3.2.2	5.4.4	G.8.4.2	J.3.8.2
3.2.3	5.5.1	G.9	J.4.2.2
3.2.5	6.1.2.7	G.10.1.1	Appendix L
3.3.1	6.1.7.2	G.10.1.2	M.2
3.3.2	6.1.8.2	G.11.3	M.4.2
3.3.3	6.3.4	H.1	N.2.1
3.3.4	6.6.11	H.2.1	N.2.2.b
3.4.1	7.2.1.1	H.3.1	N.2.4
3.6.1.1 Notes 1 & 3	8.1.1.e, f, g, j & n	H.4.1.6	N.2.5
3.6.1.2	Figure 8-1, Note	H.4.1.8	N.2.6
3.6.1.3	A.1.1	H.4.1.10	O.2.2
3.6.1.6	A.1.2	H.4.2.2	O.2.6
3.6.1.7	A.3.4	H.4.2.5	O.3.1.4
Table 3-2, Note A	A.4.1 CA	H.4.2.6	P.1
3.6.3.2 G & CA	A.6	H.4.2.9	P.8.1
3.6.4.1	A.8.2	H.4.3.1	P.8.2
3.7.1.2	B.2.2	H.4.3.3	S.1.2
3.7.1.4	B.3.3	H.4.3.3.1	S.2.1.2
3.7.3.4	B.3.4	H.4.3.4	S.2.2
3.7.4.5	B.4.4.1	H.4.3.5	Table S-1, Notes 1–3 and 5
3.7.5.2	C.1	H.4.4.2	S.3.2 G & CA
3.7.7.1	C.3.1	H.4.6.1	S.4.3.2
Figure 3-4A, Note 1	C.3.3.2	H.4.6.2	S.4.4.3
Figure 3-4B, Note 6	C.3.4.2	H.4.6.3	S.4.5.1
Table 3-8, Notes C & H	C.3.7	H.4.6.5	S.4.9.2
Table 3-9, Note C	C.3.8	H.4.6.6	S.4.10.1.1
Figure 3-5, Note 4	C.3.9	H.4.6.7	S.4.10.1.2
Figure 3-9, Note 4	C.3.10.1	H.4.6.8	S.4.13
3.7.8.1	C.3.11	H.5.1.1	S.6.a
3.8.2	C.3.13	H.5.1.4	
3.8.7	C.3.14	H.5.2.1	



## APPENDIX M—REQUIREMENTS FOR TANKS OPERATING AT ELEVATED TEMPERATURES

### M.1 Scope

**M.1.1** This appendix specifies additional requirements for API Standard 650 tanks with a maximum operating temperature exceeding 90°C (200°F) but not exceeding 260°C (500°F).

**M.1.2** The following shall not be used for operating temperatures above 90°C (200°F):

- a. Open-top tanks (see 3.9).
- b. Floating-roof tanks (see Appendix C).
- c. Bolted door sheets (see A.10 and A.11).
- d. Structurally supported aluminum dome roofs (see G.1.1 and note below).
- e. Internal floating roofs constructed of aluminum (see H.3.2 and note below).
- f. Internal floating roofs constructed of plastic (see H.3.4).

Note: An exception may be made by the purchaser for Items d and e, if the following criteria is met:

- a. Allowable stress reductions for aluminum alloys are determined in accordance with ANSI/ASME B96.1, *Welded Aluminum Alloy Storage Tanks*, and alloys are evaluated for the potential of exfoliation.
- b. Gaskets and seals are evaluated for suitability with elevated temperatures.

**M.1.3** Internal floating roofs in accordance with Appendix H may be used for operating temperatures above 90°C (200°F), subject to the applicable requirements of this appendix. The vapor pressure of the liquid must be considered. Sealing devices, particularly those of fabric and nonmetallic materials, shall be suitable for the temperature.

**M.1.4** Tanks for small internal pressures in accordance with Appendix F may be used for operating temperatures above 90°C (200°F), subject to the requirements of M.3.6, M.3.7, and M.3.8.

**M.1.5** Shop-assembled tanks in accordance with Appendix J may be used for operating temperatures above 90°C (200°F), subject to the applicable requirements of this appendix.

**M.1.6** The nameplate of the tank shall indicate that the tank is in accordance with this appendix by the addition of M to the information required by 8.1.1. In addition, the nameplate shall be marked with the maximum operating temperature in the space indicated in Figure 8-1.

### ● M.2 Thermal Effects

This appendix does not provide detailed rules for limiting loadings and strains resulting from thermal effects, such as differential thermal expansion and thermal cycling, that may

exist in some tanks operating at elevated temperatures. Where significant thermal effects will be present, it is the intent of this appendix that the purchaser define such effects. The manufacturer shall propose, subject to the purchaser's acceptance, details that will provide strength and utility equivalent to those provided by the details specified by this standard in the absence of such effects.

For operating temperatures above 90°C (200°F), particular consideration should be given to the following thermal effects:

- a. Temperature differences between the tank bottom and the lower portion of the shell. Such thermal differences may result from factors such as the method and sequence of filling and heating or cooling, the degree of internal circulation, and heat losses to the foundation and from the shell to the atmosphere. With such temperature differences, it may be necessary to provide for increased piping flexibility, an improved bottom-to-shell joint, and a thicker annular ring or bottom sketch plates to compensate for increased rotation of the bottom-to-shell joint (see M.4.2).
- b. The ability of the bottom to expand thermally, which may be limited by the method of filling and heating. With such a condition, it may be necessary to provide improved bottom welding in addition to the details suggested in Item a.
- c. Temperature differences or gradients between members, such as the shell and the roof or stairways, the shell and stiffeners, the roof or shell and the roof supports, and locations with insulation discontinuities.
- d. Whether or not the contents are allowed to solidify and are later reheated to a liquid, including the effect on columns, beams, and rafters. The possible buildup of solids on these components and the potential for plugging of the vent system should also be considered.
- e. The number and magnitude of temperature cycles the tank is expected to undergo during its design life.

### M.3 Modifications in Stress and Thickness

**M.3.1** For operating temperatures not exceeding 90°C (200°F), the allowable stress specified in 3.6.2 (Table 3-2) for calculating shell thickness need not be modified.

**M.3.2** For operating temperatures exceeding 90°C (200°F), the allowable stress specified in 3.6.2 shall be modified as follows: The allowable stress shall be two-thirds the minimum specified yield strength of the material multiplied by the applicable reduction factor given in Table M-1 or the value given in Table 3-2 for product design stress, whichever is less.

Table M-1—Yield Strength Reduction Factors

Temperature		Minimum Specified Yield Strength [MPa (lbf/in. <sup>2</sup> )]		
		< 310 MPa (< 45,000 lbf/in. <sup>2</sup> )	From ≥ 310 to < 380 MPa (≥ 45,000 to < 55,000 lbf/in. <sup>2</sup> )	≥ 380 MPa (≥ 55,000 lbf/in. <sup>2</sup> )
(°C)	(°F)			
91	201	0.91	0.88	0.92
150	300	0.88	0.81	0.87
200	400	0.85	0.75	0.83
260	500	0.80	0.70	0.79

Note: Linear interpolation shall be applied for intermediate values.

**M.3.3** The allowable stress of 145 MPa (21,000 lbf/in.<sup>2</sup>) in the equation for shell-plate thickness in A.4.1 shall be multiplied by the applicable reduction factor given in Table M-1.

**M.3.4** The requirements of 3.7.7 for flush-type cleanout fittings and of 3.7.8 for flush-type shell connections shall be modified. The thickness of the bottom reinforcing plate, bolting flange, and cover plate shall be multiplied by the ratio of 205 MPa (30,000 psi) to the material yield strength at the maximum operating temperature if the ratio is greater than one.

**M.3.5** The structural allowable stresses specified in 3.10.3, including the allowable stresses dependent on the modulus of elasticity, shall be multiplied by the ratio of the material's yield strength at the maximum operating temperature to 205 MPa (30,000 psi) if the ratio is less than 1.0 (see Table M-1 for yield strength reduction factors).

**M.3.6** In the two equations in F.4.1 and F.5, the value 1.1 (30,800) shall be multiplied by the ratio of the material's yield strength at the maximum operating temperature to 205 MPa (30,000 psi) if the ratio is less than 1.0 (see Table M-1 for yield strength reduction factors).

**M.3.7** The allowable stress specified in F.7.2 shall be multiplied by the ratio of the material's yield strength at the maximum operating temperature to 188 MPa (27,300 psi) if the ratio is less than 1.0 (see Table M-1 for yield strength reduction factors).

**M.3.8** If the anchors are insulated, the allowable stresses specified in Table F-1 shall be multiplied by the ratio of the material's yield strength at the maximum operating temperature to 205 MPa (30,000 psi) if the ratio is less than 1.0 (see Table M-1 for yield strength reduction factors).

## M.4 Tank Bottoms

**M.4.1** Tanks with diameters exceeding 30 m (100 ft) shall have butt-welded annular bottom plates (see 3.1.5.6).

- **M.4.2** The following simplified procedure is offered as a recommended design practice for elevated-temperature tanks

where significant temperature differences between the tank bottom and the lowest shell course are expected. The use of the procedure is not intended to be mandatory. It is recognized that other analytical procedures can be employed as well as that operating conditions may preclude the need for such a procedure.

Shell-to-bottom junctions in elevated-temperature tanks may be evaluated for liquid head and temperature cycles with the formulas, procedures, and exclusions given below. (See Conditions a and b in the note below, which exclude tanks from such analyses.)

Note: A cyclic design life evaluation need not be made if all the criteria of either of the following conditions are met:

- The design temperature difference ( $T$ ) is less than or equal to 220°C (400°F),  $K$  is less than or equal to 2.0, and  $C$  is less than or equal to 0.5.
- A heated liquid head, in feet, greater than or equal to  $0.3(Dt)^{0.5}$  is normally maintained in the tank, except for an occasional cool-down (about once a year) to ambient temperatures;  $T$  is less than or equal to 260°C (500°F); and  $K$  is less than or equal to 4.0. (For background information on the development of the stress formulas, design life criteria, and  $C$  and  $B$  factors, see G. G. Karcher, "Stresses at the Shell-to-Bottom Junction of Elevated-Temperature Tanks.")<sup>16</sup>

In SI units:

$$N = \left( \frac{9.7 \times 10^3}{KS} \right)^{2.44}$$

(If  $N$  is greater than or equal to 1300, cycling at the shell-to-bottom junction is not a controlling factor.)

where

$N$  = number of design liquid level and temperature cycles estimated for the tank design life (usually less than 1300). This design procedure contains a conservative

<sup>16</sup>G. G. Karcher, "Stresses at the Shell-to-Bottom Junction of Elevated-Temperature Tanks," *1981 Proceedings—Refining Department*, Volume 60, American Petroleum Institute, Washington, D.C., 1981, pp. 154–159.

safety margin. It is not necessary to monitor actual in-service temperature and liquid head cycles,

- $K$  = stress concentration factor for the bottom plate at the toe of the inside shell-to-bottom fillet weld,  
 = 4.0 for shell-to-bottom fillet welds and lap-welded bottom plates,  
 = 2.0 for butt-welded annular plates where the shell-to-bottom fillet welds have been inspected by 100% magnetic particle examination (see 6.2). This magnetic particle examination shall be performed on the root pass at every 13 mm of deposited weld metal while the weld is being made and on the completed weld. The examination shall be performed before hydrostatic testing,

the tank's operating and warm-up procedure and heat transfer to the subgrade (see footnote 16),

- = 0.85 if no  $C$  factor is specified by the purchaser,  
 $B$  = foundation factor (see footnote 16),  
 = 2.0 for tanks on earth foundations,  
 = 4.0 for tanks on earth foundations with a concrete ringwall.

In US Customary units:

$$N = \left( \frac{1.4 \times 10^6}{KS} \right)^{2.44}$$

(If  $N$  is greater than or equal to 1300, cycling at the shell-to-bottom junction is not a controlling factor.)

where

- $N$  = number of design liquid level and temperature cycles estimated for the tank design life (usually less than 1300). This design procedure contains a conservative safety margin. It is not necessary to monitor actual in-service temperature and liquid head cycles,  
 $K$  = stress concentration factor for the bottom plate at the toe of the inside shell-to-bottom fillet weld,  
 = 4.0 for shell-to-bottom fillet welds and lap-welded bottom plates,  
 = 2.0 for butt-welded annular plates where the shell-to-bottom fillet welds have been inspected by 100% magnetic particle examination (see 6.2). This magnetic particle examination shall be performed on the root pass at every  $1/2$  inch of deposited weld metal while the weld is being made and on the completed weld. The examination shall be performed before hydrostatic testing,

$$S = \frac{0.028D^2 t_b^{0.25}}{t} \times \left[ \frac{58HG}{(Dt)^{0.5}} + \frac{26.2CTt^{0.5}}{D^{1.5}} - \frac{4.8BS_y t_b^2}{(Dt)^{1.5}} - G \right]$$

- = one-half the maximum stress range that occurs in the annular plate at the shell-to-bottom junction weld, in MPa. The  $H$  and  $CT$  terms must be large enough to cause a positive  $S$ . A negative  $S$  indicates that loading conditions are not sufficient to satisfy the development assumptions of this formula. Specifically stated, the following inequality must be satisfied when the equation for  $S$  is used:

$$\left[ \frac{58HG}{(Dt)^{0.5}} + \frac{26.2CTt^{0.5}}{D^{1.5}} - G \right] > \frac{4.8BS_y t_b^2}{(Dt)^{1.5}}$$

When the equation for  $S$  is used, the shell thickness  $t$  must be greater than or equal to the annular-plate thickness  $t_b$ ,

- $T$  = difference between the minimum ambient temperature and the tank's maximum operating temperature ( $^{\circ}\text{C}$ ),  
 $S_y$  = specified minimum yield strength of the bottom plate at the tank's maximum operating temperature (MPa),  
 $D$  = nominal tank diameter (m),  
 $H$  = difference in filling height between the full level and the low level (m),  
 $G$  = design specific gravity of the liquid,  
 $t$  = nominal thickness of the tank's bottom shell course (mm),  
 $t_b$  = nominal thickness of the annular bottom plate (mm),  
 $C$  = factor to account for radial restraint of the tank's shell-to-bottom junction with respect to free thermal expansion ( $C_{max} = 1.0$ ;  $C_{min} = 0.25$ ). The actual design value of  $C$  shall be established considering

$$S = \frac{0.033D^2 t_b^{0.25}}{t} \times \left[ \frac{6.3HG}{(Dt)^{0.5}} + \frac{436CTt^{0.5}}{D^{1.5}} - \frac{BS_y t_b^2}{(Dt)^{1.5}} - G \right]$$

- = one-half the maximum stress range that occurs in the annular plate at the shell-to-bottom junction weld, in pounds per square inch. The  $H$  and  $CT$  terms must be large enough to cause a positive  $S$ . A negative  $S$  indicates that loading conditions are not sufficient to satisfy the development assumptions of this formula. Specifically stated, the following inequality must be satisfied when the equation for  $S$  is used:

$$\left[ \frac{6.3HG}{(Dt)^{0.5}} + \frac{436CTt^{0.5}}{D^{1.5}} - G \right] > \frac{BS_y t_b^2}{(Dt)^{1.5}}$$

When the equation for  $S$  is used, the shell thickness  $t$  must be greater than or equal to the annular-plate thickness  $t_b$ ,

$T$  = difference between the minimum ambient temperature and the tank's maximum operating temperature (°F),

$S_y$  = specified minimum yield strength of the bottom plate at the tank's maximum operating temperature (lbf/in.<sup>2</sup>),

$D$  = nominal tank diameter (ft),

$H$  = difference in filling height between the full level and the low level (ft),

$G$  = design specific gravity of the liquid,

$t$  = nominal thickness of the tank's bottom shell course (in.),

$t_b$  = nominal thickness of the annular bottom plate (in.),

$C$  = factor to account for radial restraint of the tank's shell-to-bottom junction with respect to free thermal expansion ( $C_{max} = 1.0$ ;  $C_{min} = 0.25$ ). The actual design value of  $C$  shall be established considering the tank's operating and warm-up procedure and heat transfer to the subgrade (see footnote 16),

= 0.85 if no  $C$  factor is specified by the purchaser,

$B$  = foundation factor (see footnote 16),

= 2.0 for tanks on earth foundations,

= 4.0 for tanks on earth foundations with a concrete ringwall.

## M.5 Self-Supporting Roofs

**M.5.1** The requirements of 3.10.5 and 3.10.6, which are applicable to self-supporting roofs, shall be modified. For operating temperatures above 90°C (200°F), the calculated minimum thickness of roof plates, as defined in 3.10.5 and 3.10.6, shall be increased by the ratio of 199,000 MPa (28,800,000 psi) to the material's modulus of elasticity at the maximum operating temperature.

**M.5.2** Table M-2 shall be used to determine the material's modulus of elasticity at the maximum operating temperature.

## M.6 Wind Girders

In the equation for the maximum height of unstiffened shell in 3.9.7.1, the maximum height ( $H_1$ ) shall be reduced by the ratio of the material's modulus of elasticity at the maximum operating temperature to 199,000 MPa (28,800,000 psi) when the ratio is less than 1.0 (see Table M-2 for modulus of elasticity values).

Table M-2—Modulus of Elasticity at the Maximum Operating Temperature

Maximum Operating Temperature		Modulus of Elasticity	
°C	°F	MPa	lbf/in. <sup>2</sup>
90	200	199,000	28,800,000
150	300	195,000	28,300,000
200	400	191,000	27,700,000
260	500	188,000	27,300,000

Note: Linear interpolation shall be applied for intermediate values.

## APPENDIX N—USE OF NEW MATERIALS THAT ARE NOT IDENTIFIED

### N.1 General

New or unused plates and seamless or welded pipe that are not completely identified as complying with any listed specification may be used in the construction of tanks covered by this standard, under the conditions specified in N.2.

### N.2 Conditions

- **N.2.1** A material may be used if an authentic test record for each heat or heat-treating lot of material is available that proves that the material has chemical requirements and mechanical properties within the permissible range of a specification listed in this standard. If the test requirements of the listed specification are more restrictive than any specification or authentic tests that have been reported for the material, more restrictive tests shall be performed in accordance with the requirements of the listed specification, and the results shall be submitted to the purchaser for approval.

**N.2.2** If an authentic test record is not available or if all the material cannot be positively identified with the test record by legible stamping or marking, the following requirements apply:

a. Each plate shall be subjected to the chemical analysis and physical tests required by the designated specification, with the following modifications: The carbon and manganese contents shall be determined in all check analyses. When the designated specification does not specify carbon and manganese limits, the purchaser shall decide whether these contents are acceptable. When the direction of rolling is not definitely known, two tension specimens shall be taken at right angles to each other from a corner of each plate, and one tension specimen shall meet the specification requirements.

- b. Each length of pipe shall be subjected to a chemical check analysis and sufficient physical tests to satisfy the purchaser that all of the material is properly identified with a given heat or heat-treatment lot and that the chemical and physical requirements of the designated specification are met. Material specified as suitable for welding, cold bending, close coiling, and the like shall be given sufficient check tests to satisfy the purchaser that each length of material is suitable for the fabrication procedure to be used.

**N.2.3** Charpy impact tests must be performed when required by Figure 2-1 to verify that the material possesses the toughness required by Table 2-4.

- **N.2.4** After a material is properly identified with a designated specification and the purchaser is satisfied that the material complies with the specification in all respects, the testing agency shall stencil or otherwise mark, as permitted by the specification, a serial S number on each plate or each length of pipe (or as alternatively provided for small sizes in the specification) in the presence of the purchaser.

- **N.2.5** Suitable report forms clearly marked “Report on Tests of Nonidentified Materials” shall be furnished by the tank manufacturer or testing agency. The forms shall be properly filled out, certified by the testing agency, and approved by the purchaser.

- **N.2.6** The purchaser shall have the right to accept or reject the testing agency or the test results.

**N.2.7** The requirements for fabrication applicable to the designated specification to which the nonidentified material corresponds shall be followed, and the allowable design stress values shall be those specified in this standard for the corresponding specification.



## APPENDIX O—RECOMMENDATIONS FOR UNDER-BOTTOM CONNECTIONS

### O.1 Scope

This appendix contains recommendations to be used for the design and construction of under-bottom connections for storage tanks. The recommendations are offered to outline good practice and to point out certain precautions that are to be observed. Reference should be made to Appendix B for considerations involving foundation and subgrade.

### O.2 Recommendations

**O.2.1** The recommendations of this appendix are intended for use only where significant foundation settlement is not expected. It is not possible to establish precise limits, but if predicted settlement exceeds 13 mm ( $1/2$  in.), the recommendations should be subjected to detailed engineering review for possible additions, modifications, or elimination of bottom connections. Particular consideration shall be given to possible differential settlement in the immediate area of the bottom connection and with respect to connecting piping.

- **O.2.2** The arrangement and details of bottom connections may be varied to achieve the utility, tightness, and strength required for the prevailing foundation conditions. The details shown in Figures O-1, O-2, and O-3 are examples. Figures O-1 and O-2 show details used on a concrete ringwall foundation, but similar designs may be used on earth foundations. Figure O-3 shows another detail used on earth foundations. Other arrangements of foundation and connection (including combination sump and pipe) may be used under the provisions of O.2.6. When required by the purchaser, seismic considerations (see Appendix E) shall be included.

**O.2.3** Support of the pipe by the soil and bottom connection shall be evaluated to confirm adequacy and resistance to

liquid, static, and dynamic loads. Both deflection and stress shall be considered in the evaluation.

**O.2.4** Consideration shall be given to predicted settlement that would affect the relative positions of the tank and pipe or pipe supports outside the tank (see O.2.1).

**O.2.5** Bottom connections used in floating-roof tanks shall be provided with a baffle to prevent impingement of the inlet product stream directly against the floating roof.

- **O.2.6** All details are subject to agreement between the purchaser and the manufacturer.

### O.3 Guideline Examples

#### O.3.1 CONCRETE VAULT AND RINGWALL (SEE FIGURES O-1 AND O-2)

**O.3.1.1** The concrete ceiling vault shown in Figure O-2 provides improved support of the tank bottom and shell and provides more uniform reinforcing-bar distribution around the ringwall opening than the details shown in Figure O-1 provide.

**O.3.1.2** Particular attention is required for the backfill specifications and placement of the backfill around the vault area and around the inside of the entire ringwall. Compaction shall be adequate to prevent significant localized settlement.

**O.3.1.3** Consideration should be given to the soil characteristics at the different elevations at the bottom of the ringwall and the vault, especially for the deeper vaults to accommodate the larger connections.

- **O.3.1.4** Recommended details and dimensions are shown in Figures O-1 and O-2 and Table O-1. Dimension

Table O-1—Dimensions of Under-Bottom Connections

Inlet Diameter NPS	mm (in.)										
	<i>D</i>	<i>B/2</i>	<i>E</i>	<i>F</i>	<i>G</i>	<i>H</i>	<i>J</i>	<i>K</i>	<i>L</i>	<i>W/2</i>	<i>T<sup>a</sup></i>
6	525 (21)	225 (9)	350 (14)	750 (30)	575 (23)	300 (12)	1125 (44)	1975 (78)	925 (36)	16 ( $5/8$ )	ST4WF8.5
8	550 (22)	250 (10)	400 (16)	825 (32)	650 (26)	300 (12)	1150 (45)	2050 (81)	950 (37)	16 ( $5/8$ )	ST4WF8.5
12	600 (24)	300 (12)	450 (18)	875 (34)	750 (30)	300 (12)	1200 (47)	2150 (85)	1000 (39)	16 ( $5/8$ )	ST6WF13.5
18	675 (27)	375 (15)	500 (20)	950 (37)	900 (35)	300 (12)	1300 (51)	2325 (92)	1075 (42)	16 ( $5/8$ )	ST6WF13.5
24	750 (30)	450 (18)	600 (24)	1050 (41)	1075 (42)	300 (12)	1400 (55)	2550 (100)	1150 (45)	16 ( $5/8$ )	ST6WF13.5
30	850 (33)	525 (21)	750 (30)	1150 (45)	1300 (51)	300 (12)	1500 (59)	2750 (108)	1225 (48)	16 ( $5/8$ )	ST6WF13.5
36	925 (36)	625 (25)	925 (36)	1275 (50)	1550 (61)	300 (12)	1625 (64)	3000 (118)	1300 (51)	16 ( $5/8$ )	ST8WF18.0
42	1000 (39)	700 (28)	1075 (42)	1375 (54)	1775 (70)	300 (12)	1725 (68)	3200 (126)	1375 (54)	16 ( $5/8$ )	ST8WF18.0
48	1075 (42)	825 (32)	1225 (48)	1475 (58)	2025 (80)	300 (12)	1825 (72)	3400 (134)	1450 (57)	16 ( $5/8$ )	ST8WF18.0

<sup>a</sup>Applies only to Figure O-1. For tank heights greater than 19.2–21.6 mm (64–72 ft) inclusive, 19 mm ( $3/4$ -in.) plate shall be used. *T* shall not be less than the thickness of the annular plate.

<sup>b</sup>Other composite sections may be used to support the load.

Note: See Figures O-1 and O-2. For diameters not shown, the dimensions of the next larger size shall be used.

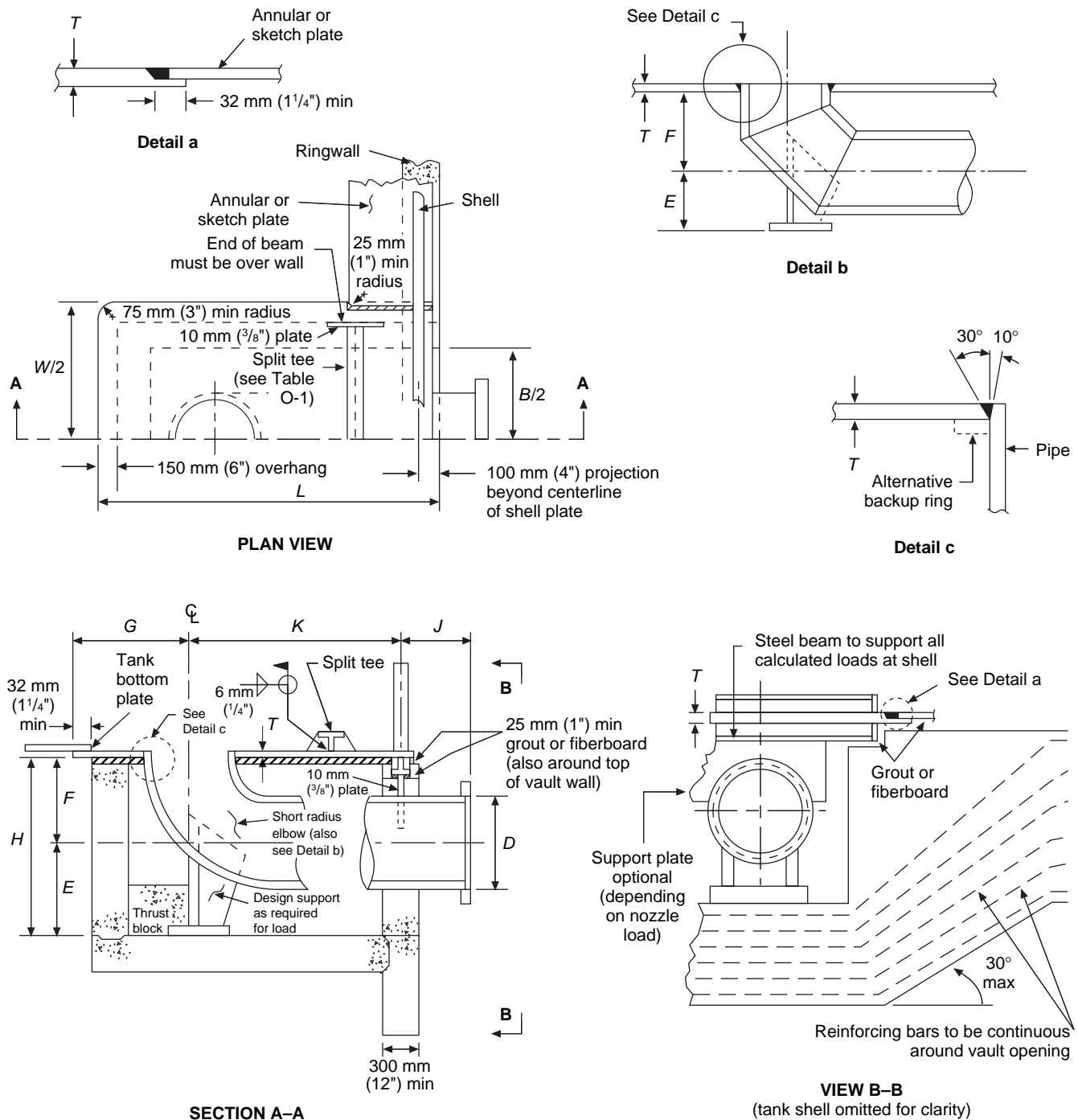
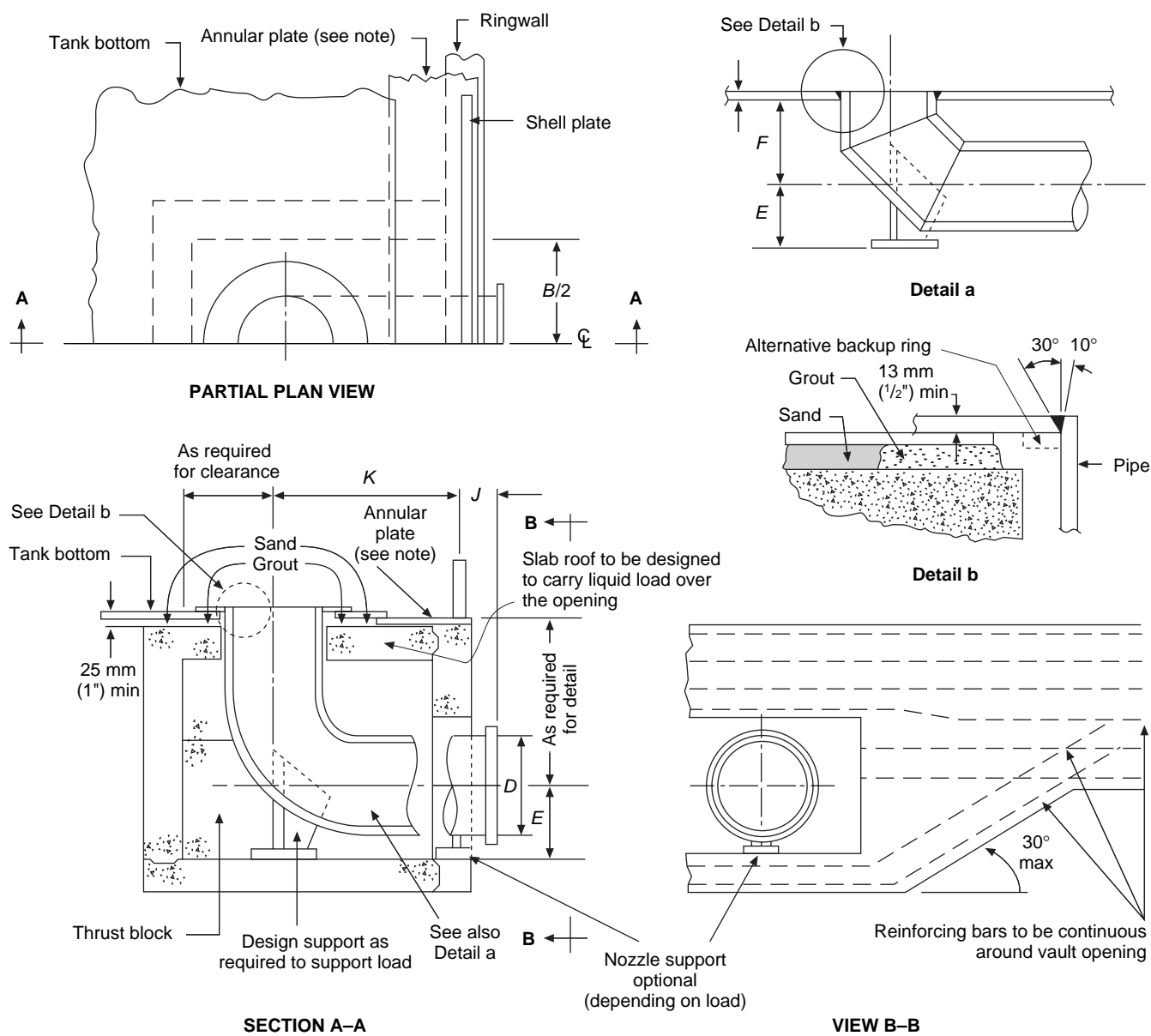

Figure O-1—Example of Under-Bottom Connection With Concrete Ringwall Foundation

*K* is considered adequate to place the connection out of the influence of shell-to-bottom rotation when the tank is statically loaded. Seismic loading shall be analyzed for additional considerations. The method shall be a matter of agreement between the manufacturer and the purchaser. When the tank bottom has annular plates (thicker than the tank bottom), it is recommended either to pro-

vide at least 300 mm (12 in.) between the edge of the pipe connection or reinforcing plate and the inner edge of the annular plate or to locally extend the annular plate, thickened if necessary, to encompass the bottom connection. The dimensions in Table O-1 may be changed to achieve desired clearances for installations, inspections, and the like.



Note: If sketch plates are used, a full plate shall be located over the vault.

Figure O-2—Example of Under-Bottom Connection With Concrete Ringwall Foundation and Improved Tank Bottom and Shell Support

**0.3.1.5** Concrete walls, floors, and ceilings shall be designed to meet the minimum requirements of ACI 318 and local soil conditions.

**0.3.2 EARTH FOUNDATION (SEE FIGURE O-3)**

**0.3.2.1** The detail shown in Figure O-3 provides an alternative arrangement for tanks where a concrete ringwall is not provided.

**0.3.2.2** Soil and backfill support capability shall be evalu-

ated to ensure that reasonably uniform settlement (if any) will occur under the loads imposed.

**0.3.2.3** When the pipe is connected to the bottom at an angle, consideration should be given to design for unbalanced forces if the pipe is trimmed flush with the bottom.

**0.3.2.4** When seismically-induced loadings are specified, such loadings under the tank bottom and shell shall be considered when the depth and type of backfill around and over the pipe are selected.

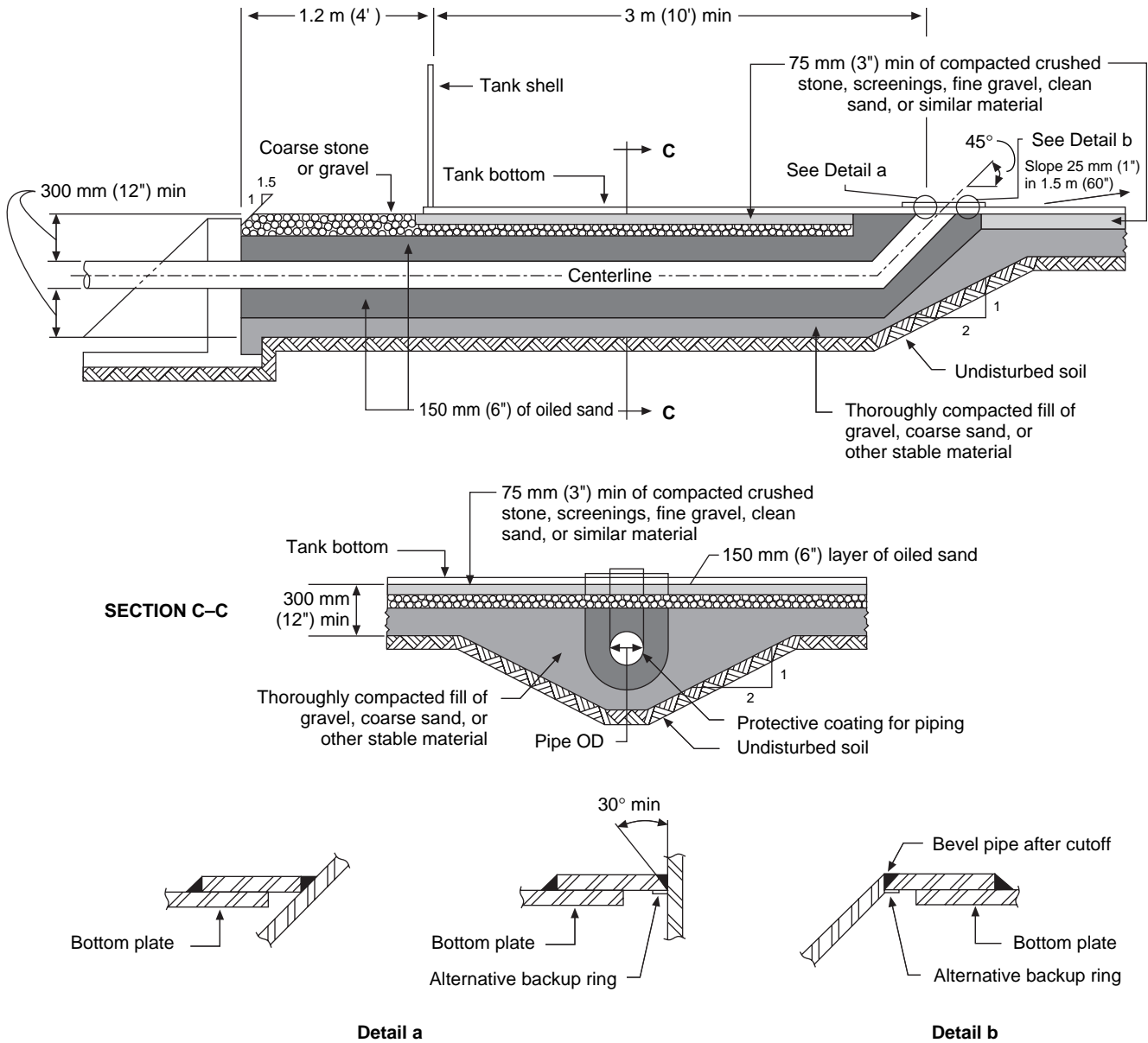

Note: This type of connection shall not be used for tanks with a diameter of less than 6 m (20 ft).

Figure O-3—Example of Under-Bottom Connection With Earth-Type Foundation

## APPENDIX P—ALLOWABLE EXTERNAL LOADS ON TANK SHELL OPENINGS

Note: This appendix is based on H. D. Billimoria and J. Hagstrom's "Stiffness Coefficients and Allowable Loads for Nozzles in Flat Bottom Storage Tanks"<sup>17</sup> and H. D. Billimoria and K. K. Tam's "Experimental Investigation of Stiffness Coefficients and Allowable Loads for a Nozzle in a Flat Bottom Storage Tank."<sup>18</sup>

### ● P.1 Scope

00 | This appendix establishes minimum recommendations for the design of storage-tank openings that conform to Table 3-6 and will be subjected to external piping loads. This appendix shall be used only when specified by the purchaser and is recommended only for tanks larger than 36 m (120 ft) in diameter. The recommendations of this appendix represent accepted practice for the design of shell openings in the lower half of the bottom shell course that have a minimum elevation from the tank bottom and meet the requirements of Table 3-6. It is recognized that the purchaser may specify other procedures, special factors, and additional requirements. When the use of this appendix is specified, any deviation from its requirements shall be mutually agreed upon by the purchaser and the manufacturer. It is not intended that this appendix necessarily be applied to piping connections similar in size and configuration to those on tanks of similar size and thickness for which satisfactory service experience is available.

### P.2 General

The design of an external piping system that will be connected to a thin-walled, large-diameter cylindrical vertical storage tank may pose a problem in the analysis of the interface between the piping system and the tank opening connections. The piping designer must consider the stiffness of the tank shell and the radial deflection and meridional rotation of the shell opening at the opening-shell connection resulting from product head, pressure, and uniform or differential temperature between the shell and the bottom. The work of the piping designer and the tank designer must be coordinated to ensure that the piping loads imposed on the shell opening by the connected piping are within safe limits. Although three primary forces and three primary moments may be applied to the mid-surface of the shell at an opening connection, only one force,  $F_R$ , and two moments,  $M_L$  and  $M_C$ , are normally considered significant causes of shell deformation (see P.3 for a description of the nomenclature).

<sup>17</sup>H. D. Billimoria and J. Hagstrom, "Stiffness Coefficients and Allowable Loads for Nozzles in Flat Bottom Storage Tanks," Paper 77-PVP-19, American Society of Mechanical Engineers, New York, 1977.

<sup>18</sup>H. D. Billimoria and K. K. Tam, "Experimental Investigation of Stiffness Coefficients and Allowable Loads for a Nozzle in a Flat Bottom Storage Tank," Paper 80-C2/PVP-59, American Society of Mechanical Engineers, New York, 1980.

### P.3 Nomenclature

$a$  = outside radius of the opening connection (mm) (in.),  
 $E$  = modulus of elasticity (MPa) (lbf/in.<sup>2</sup>) (see Table P-1),  
 $F_R$  = radial thrust applied at the mid-surface of the tank shell at the opening connection (N) (lbf),  
 $F_P$  = pressure end load on the opening for the pressure resulting from the design product head at the elevation of the opening centerline,  $\pi a^2 P$  (N) (lbf),  
 $G$  = design specific gravity of the liquid,  
 $H$  = maximum allowable tank filling height (mm) (in.),  
 $K_C$  = stiffness coefficient for the circumferential moment (N-mm/radian) (in.-lbf/radian),  
 $K_L$  = stiffness coefficient for the longitudinal moment (N-mm/radian) (in.-lbf/radian),  
 $K_R$  = stiffness coefficient for the radial thrust load (N/mm) (lbf/in.),  
 $L$  = vertical distance from the opening centerline to the tank bottom (mm) (in.),  
 $M_C$  = circumferential moment applied to the mid-surface of the tank shell (N-mm) (in.-lbf),  
 $M_L$  = longitudinal moment applied to the mid-surface of the tank shell (N-mm) (in.-lbf),  
 $P$  = pressure resulting from product head at the elevation of the opening centerline (MPa) (lbf/in.<sup>2</sup>),  
 $R$  = nominal tank radius (mm) (in.),  
 $t$  = shell thickness at the opening connection (mm) (in.),  
 $\Delta T$  = normal operating temperature minus installation temperature (°C) (°F),  
 $W$  = unrestrained radial growth of the shell (mm) (in.),  
 $W_R$  = resultant radial deflection at the opening connection (mm) (in.),  
 $X_A = L + a$  (mm) (in.),  
 $X_B = L - a$  (mm) (in.),  
 $X_C = L$  (mm) (in.),  
 $Y_C$  = coefficient determined from Figure P-4B,  
 $Y_F, Y_L$  = coefficients determined from Figure P-4A,  
 $\alpha$  = thermal expansion coefficient of the shell material [mm/(mm-°C)] [in./in.-°F] (see Table P-1),  
 $\beta$  = characteristic parameter,  $1.285/(Rt)^{0.5}$  (1/mm) (1/in.),  
 $\lambda = a / (Rt)^{0.5}$ ,

Table P-1—Modulus of Elasticity and Thermal Expansion Coefficient at the Design Temperature

Design Temperature		Modulus of Elasticity MPa (psi) <i>E</i>	Thermal Expansion Coefficient <sup>a</sup> [mm × 10 <sup>-6</sup> /(mm-°C)] (inches × 10 <sup>-6</sup> per inch-°F)
°C	°F		
20	70	203,000 (29,500,000)	—
90	200	199,000 (28,800,000)	12.0 (6.67)
150	300	195,000 (28,300,000)	12.4 (6.87)
200	400	191,000 (27,700,000)	12.7 (7.07)
260	500	188,000 (27,300,000)	13.1 (7.25)

<sup>a</sup>Mean coefficient of thermal expansion, going from 20°C (70°F) to the temperature indicated.

Note: Linear interpolation may be applied for intermediate values.

$\theta$  = unrestrained shell rotation resulting from product head (radians),

$\theta_C$  = shell rotation in the horizontal plane at the opening connection resulting from the circumferential moment (radians),

$\theta_L$  = shell rotation in the vertical plane at the opening connection resulting from the longitudinal moment (radians).

## P.4 Stiffness Coefficients for Opening Connections

The stiffness coefficients  $K_R$ ,  $K_L$ , and  $K_C$  corresponding to the piping loads  $F_R$ ,  $M_L$ , and  $M_C$  at an opening connection, as shown in Figure P-1, shall be obtained by the use of Figures P-2A through P-2L. Figures P-2A through P-2L shall be used to interpolate intermediate values of coefficients.

## P.5 Shell Deflection and Rotation

### P.5.1 RADIAL GROWTH OF SHELL

The unrestrained outward radial growth of the shell at the center of the opening connection resulting from product head and/or thermal expansion shall be determined as follows:

In SI units:

$$W = \frac{9.8 \times 10^{-6} GHR^2}{Et} \times \left[ 1 - e^{-\beta L} \cos(\beta L) - \frac{L}{H} \right] + \alpha R \Delta T$$

In US Customary units:

$$W = \frac{0.036 GHR^2}{Et} \times \left[ 1 - e^{-\beta L} \cos(\beta L) - \frac{L}{H} \right] + \alpha R \Delta T$$

### P.5.2 ROTATION OF SHELL

The unrestrained rotation of the shell at the center of the nozzle-shell connection resulting from product head shall be determined as follows:

In SI units:

$$\theta = \frac{9.8 \times 10^{-6} GHR^2}{Et} \times \left\{ \frac{1}{H} - \beta e^{-\beta L} [\cos(\beta L) + \sin(\beta L)] \right\}$$

In US Customary units:

$$\theta = \frac{0.036 GHR^2}{Et} \times \left\{ \frac{1}{H} - \beta e^{-\beta L} [\cos(\beta L) + \sin(\beta L)] \right\}$$

## P.6 Determination of Loads on the Opening Connection

The relationship between the elastic deformation of the opening connection and the external piping loads is expressed as follows:

$$W_R = \frac{F_R}{K_R} - L \tan \left( \frac{M_L}{K_L} \right) + W$$

$$\theta_L = \frac{M_L}{K_L} - \tan^{-1} \left( \frac{F_R}{LK_R} \right) + \theta$$

$$\theta_C = \frac{M_C}{K_C}$$

$K_R$ ,  $K_L$ , and  $K_C$  are the shell stiffness coefficients determined from Figures P-2A through P-2L.  $W_R$ ,  $\theta_L$ , and  $\theta_C$  are the resultant radial deflection and rotation of the shell at the opening connection resulting from the piping loads  $F_R$ ,  $M_L$ , and  $M_C$  and the product head, pressure, and uniform or differential temperature between the shell and the tank bottom.  $F_R$ ,  $M_L$ , and  $M_C$  shall be obtained from analyses of piping flexibility based on consideration of the shell stiffness determined from Figures P-2A through P-2L, the shell deflection and rotation determined as described in P.5, and the rigidity and restraint of the connected piping system.

## P.7 Determination of Allowable Loads for the Shell Opening

### P.7.1 CONSTRUCTION OF NOMOGRAMS

**P.7.1.1** Determine the nondimensional quantities  $X_A/(Rt)^{0.5}$ ,  $X_B/(Rt)^{0.5}$ , and  $X_C/(Rt)^{0.5}$  for the opening configuration under consideration.

**P.7.1.2** Lay out two sets of orthogonal axes on graph paper, and label the abscissas and ordinates as shown in Figures P-3A and P-3B, where YC, YF, and YL are coefficients determined from Figures P-4A and P-4B.

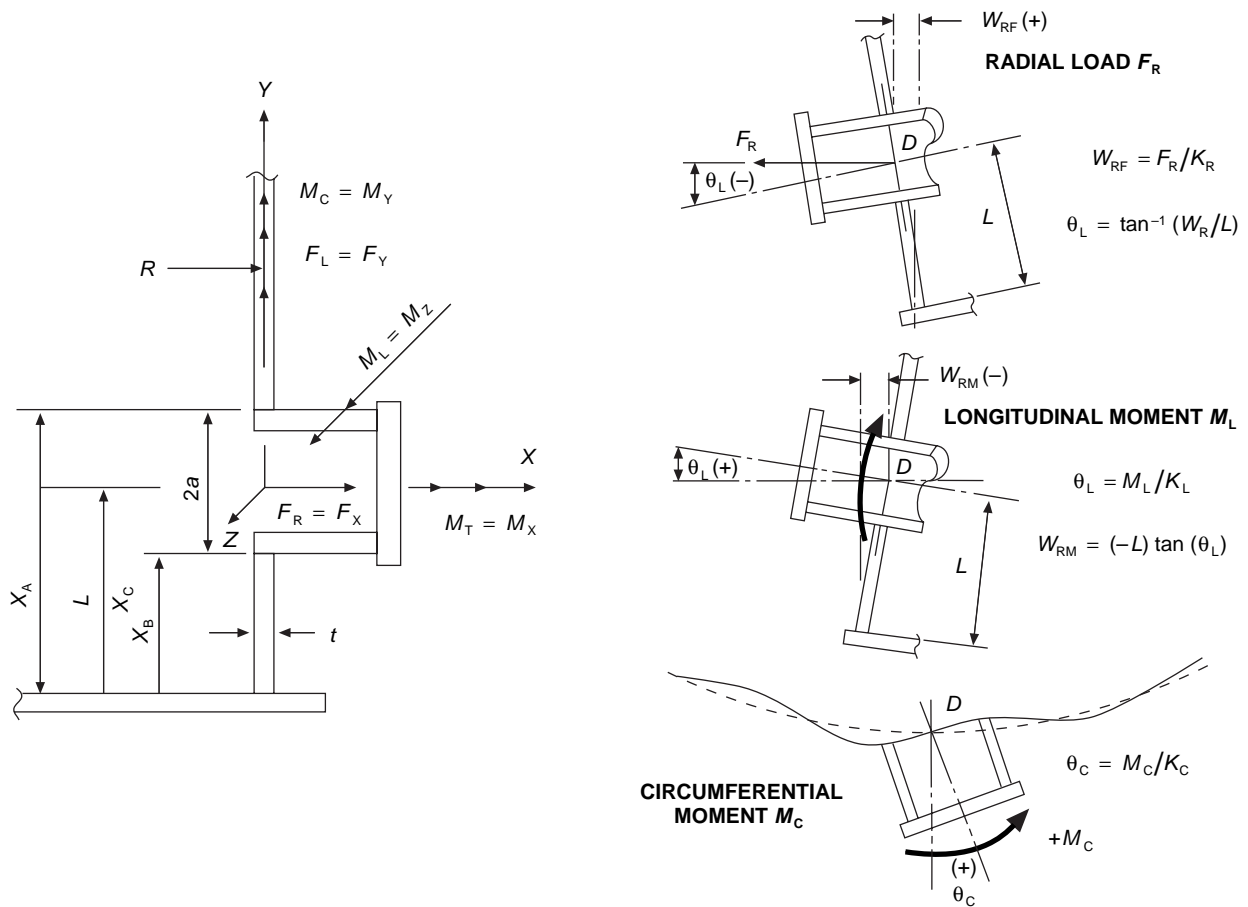

Figure P-1—Nomenclature for Piping Loads and Deformation

**P.7.1.3** Lay out two sets of orthogonal axes on graph paper, and label the abscissas and ordinates as shown in Figures P-3A and P-3B, where  $Y_C$ ,  $Y_F$ , and  $Y_L$  are coefficients determined from Figures P-4A and P-4B.

**P.7.1.4** Construct four boundaries for Figure P-3A and two boundaries for Figure P-3B. Boundaries  $b_1$  and  $b_2$  shall be constructed as lines at 45-degree angles between the abscissa and the ordinate. Boundaries  $c_1$ ,  $c_2$ , and  $c_3$  shall be constructed as lines at 45-degree angles passing through the calculated value indicated in Figures P-3A and P-3B plotted on the positive x axis.

**P.7.2 DETERMINATION OF ALLOWABLE LOADS**

**P.7.2.1** Use the values for  $F_R$ ,  $M_L$ , and  $M_C$  obtained from the piping analyses to determine the quantities  $(\lambda / 2Y_F)(F_R/F_P)$ ,  $(\lambda / aY_L)(M_L/F_P)$ , and  $(\lambda / aY_C)(M_C/F_P)$ .

**P.7.2.2** Plot the point  $(\lambda / 2Y_F)(F_R/F_P)$ ,  $(\lambda / aY_L)(M_L/F_P)$  on the nomogram constructed as shown in Figure P-5A.

**P.7.2.3** Plot the point  $(\lambda / 2Y_F)(F_R/F_P)$ ,  $(\lambda / aY_C)(M_C/F_P)$  on the nomogram constructed as shown in Figure P-5B.

**P.7.2.4** The external piping loads  $F_R$ ,  $M_L$ , and  $M_C$  to be imposed on the shell opening are acceptable if both points determined from P.7.2.2 and P.7.2.3 lie within the boundaries of the nomograms constructed for the particular opening-tank configuration.

**P.8 Manufacturer and Purchaser Responsibility**

- **P.8.1** The manufacturer is responsible for furnishing to the purchaser the shell stiffness coefficients (see P.4) and the unrestrained shell deflection and rotation (see P.5). The purchaser is responsible for furnishing to the manufacturer the magnitude of the shell-opening loads (see P.6). The manufacturer shall determine, in accordance with P.7, the acceptability of the shell-opening loads furnished by the purchaser. If the loads are excessive, the piping configuration shall be modified so that the shell-opening loads fall within the boundaries of the nomograms constructed as in P.7.1.
- **P.8.2** Changing the elevation of the opening and changing the thickness of the shell are alternative means of reducing stresses, but because these measures can affect fabrication, they may be considered only if mutually agreed upon by the purchaser and the manufacturer.

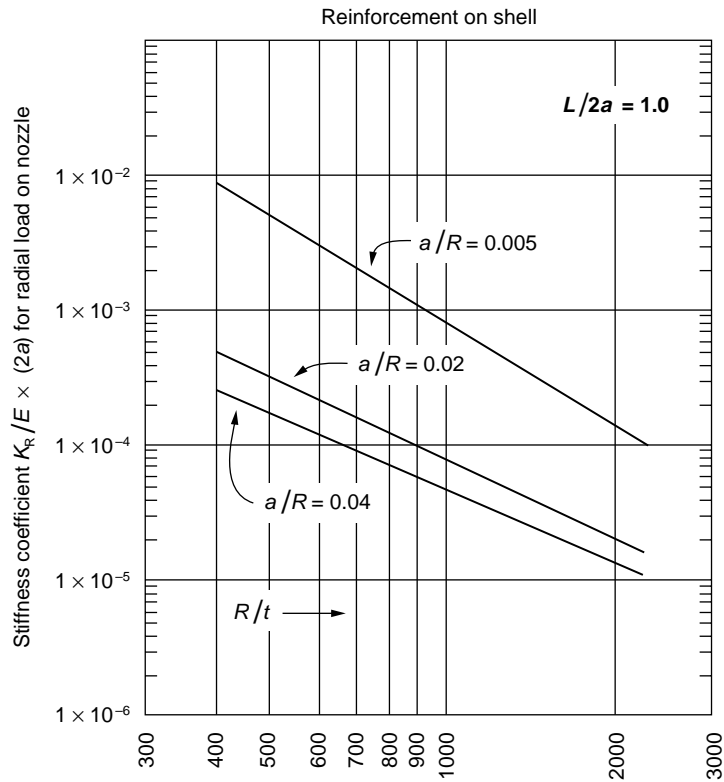

Figure P-2A—Stiffness Coefficient for Radial Load: Reinforcement on Shell ( $L / 2a = 1.0$ )

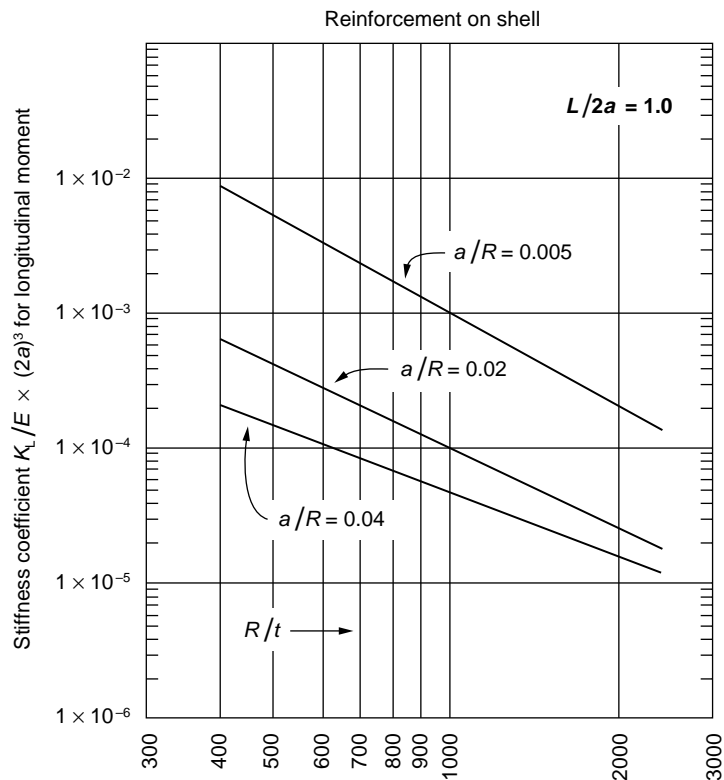

Figure P-2B—Stiffness Coefficient for Longitudinal Moment: Reinforcement on Shell ( $L / 2a = 1.0$ )

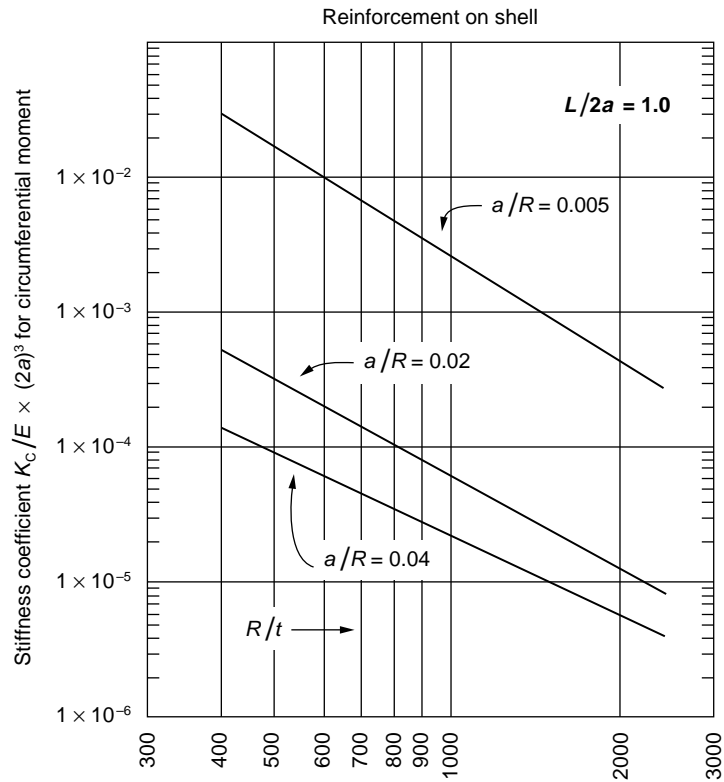

Figure P-2C—Stiffness Coefficient for Circumferential Moment: Reinforcement on Shell ( $L / 2a = 1.0$ )

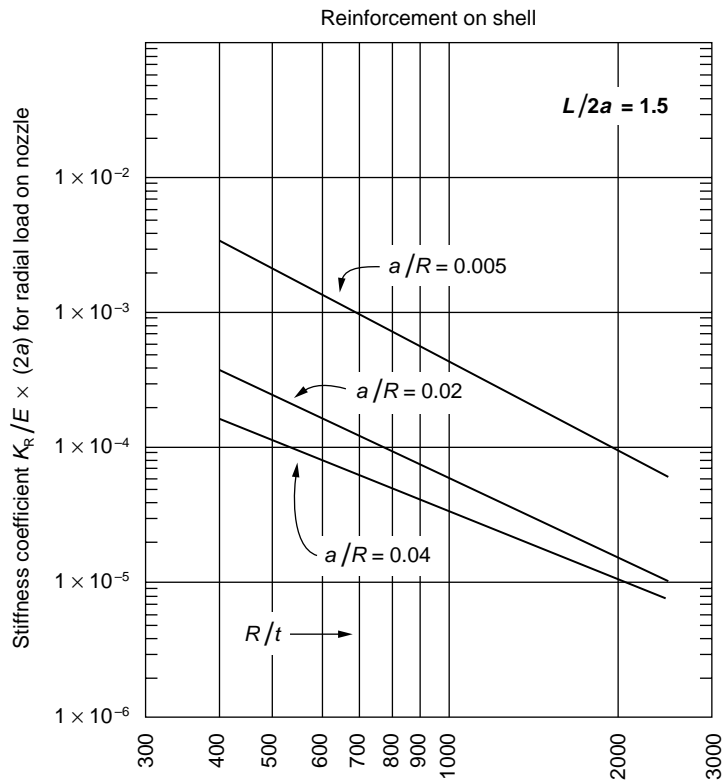

Figure P-2D—Stiffness Coefficient for Radial Load: Reinforcement on Shell ( $L / 2a = 1.5$ )

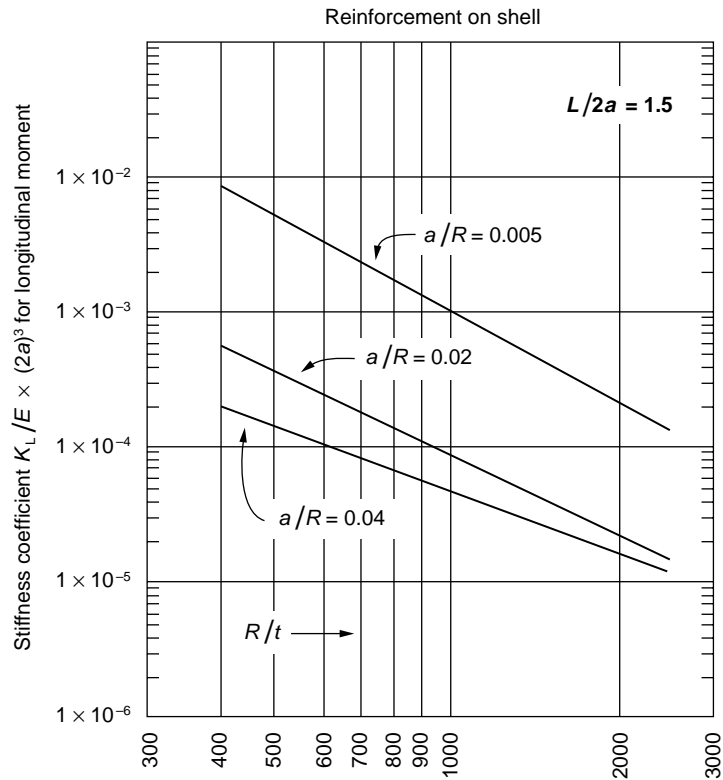

Figure P-2E—Stiffness Coefficient for Longitudinal Moment:  
Reinforcement on Shell ( $L / 2a = 1.5$ )

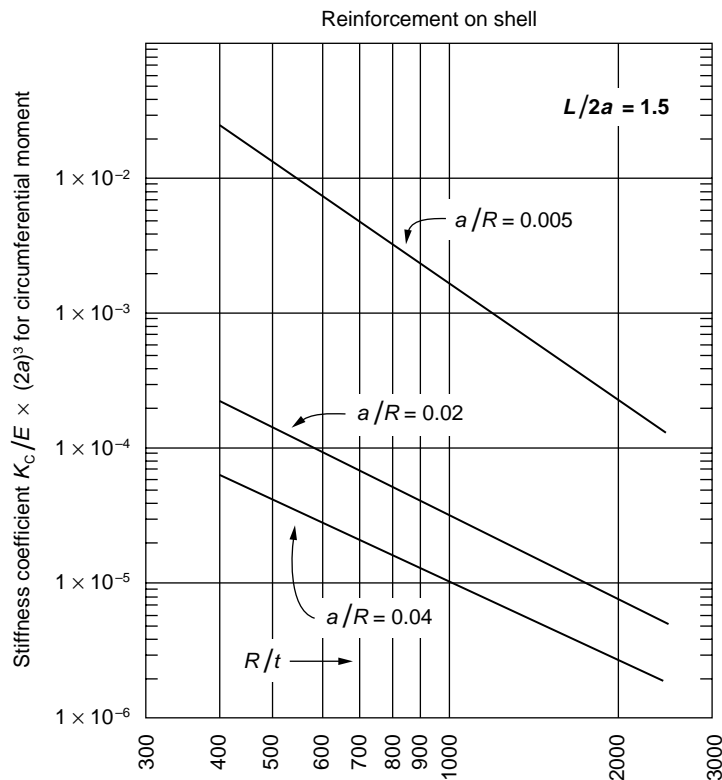

Figure P-2F—Stiffness Coefficient for Circumferential Moment:  
Reinforcement on Shell ( $L / 2a = 1.5$ )

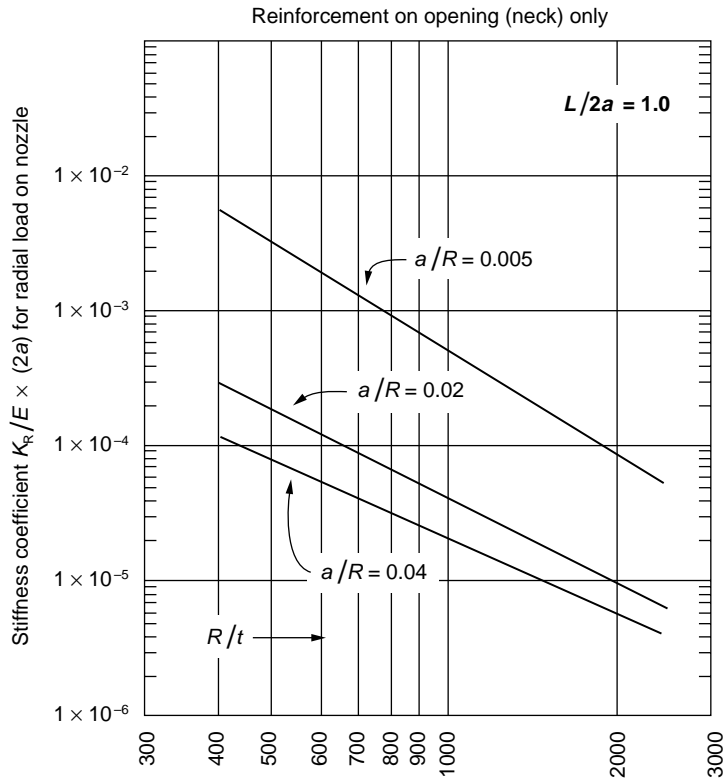

Figure P-2G—Stiffness Coefficient for Radial Load: Reinforcement in Nozzle Neck Only ( $L/2a = 1.0$ )

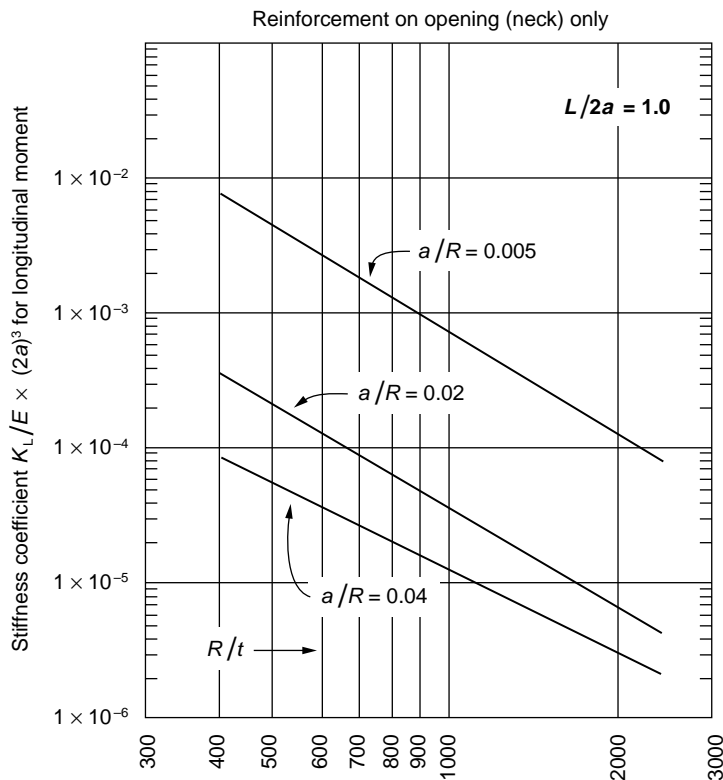

Figure P-2H—Stiffness Coefficient for Longitudinal Moment: Reinforcement in Nozzle Neck Only ( $L/2a = 1.0$ )

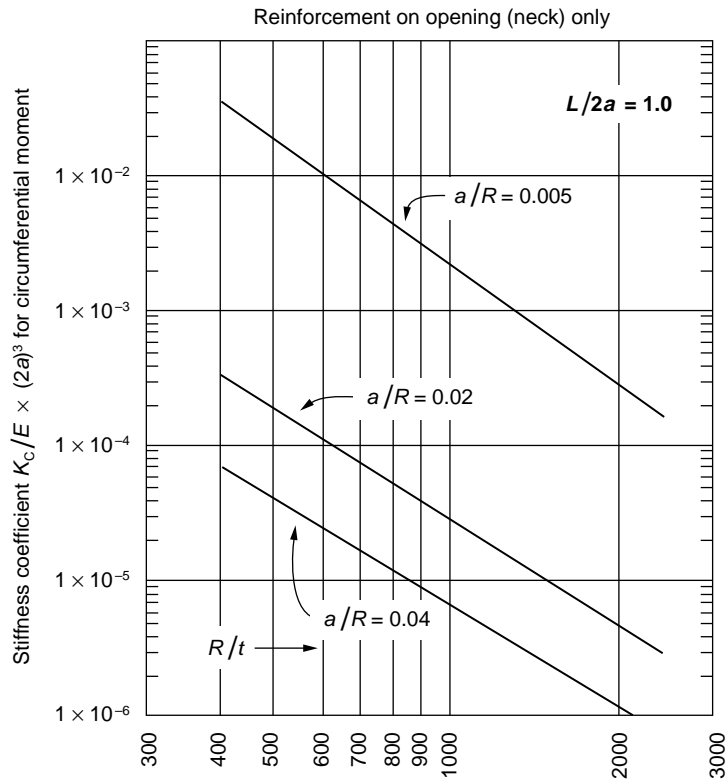

Figure P-2I—Stiffness Coefficient for Circumferential Moment: Reinforcement in Nozzle Neck Only ( $L / 2a = 1.0$ )

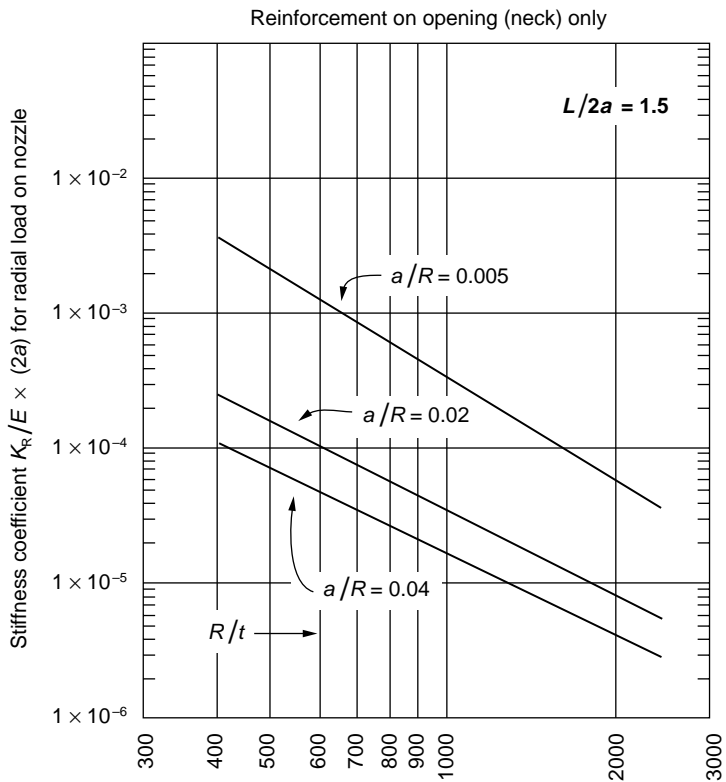

Figure P-2J—Stiffness Coefficient for Radial Load: Reinforcement in Nozzle Neck Only ( $L / 2a = 1.5$ )

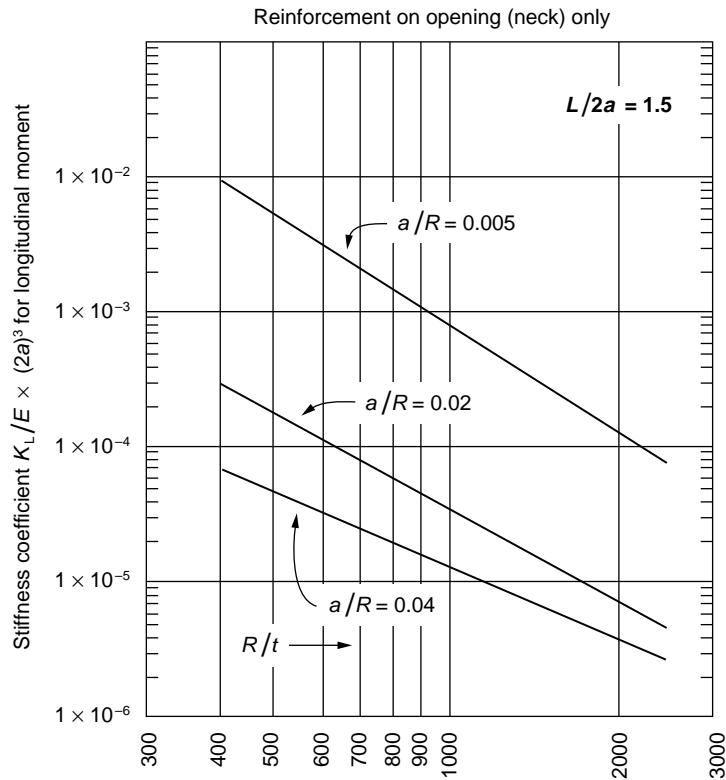

Figure P-2K—Stiffness Coefficient for Longitudinal Moment: Reinforcement in Nozzle Neck Only ( $L / 2a = 1.5$ )

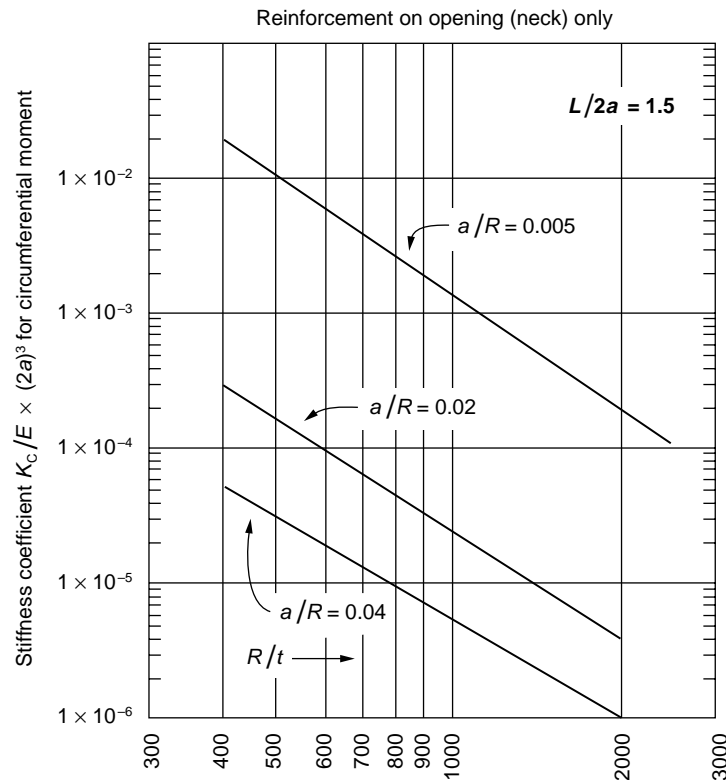

Figure P-2L—Stiffness Coefficient for Circumferential Moment: Reinforcement in Nozzle Neck Only ( $L / 2a = 1.5$ )

## P.9 Sample Problem

### P.9.1 PROBLEM

A tank is 80 m (260 ft) in diameter and 19.2 m (64 ft) high, and its bottom shell course is 34 mm (1.33 in.) thick. The tank has a low-type nozzle with an outside diameter of 610 mm (24 in.) in accordance with API Standard 650, and the nozzle centerline is 630 mm (24.75 in.) up from the bottom plate, with reinforcement on the opening (neck) only (see Figure P-6). What are the end conditions ( $W$ ,  $\theta$ ,  $K_R$ ,  $K_L$ , and  $K_C$ ) for an analysis of piping flexibility? What are the limit loads for the nozzle?

$$\begin{aligned} a &= 305 \text{ mm (12 in.)}, \\ L &= 630 \text{ mm (24.75 in.)}, \\ H &= 19,200 \text{ mm (64} \times 12 = 768 \text{ in.)}, \\ \Delta T &= 90 - 20 = 70^\circ\text{C (200} - 70 = 130^\circ\text{F)}, \\ R &= 80,000/2 = 40,000 \text{ mm ((260} \times 12)/2 = 1560 \text{ in.)}, \\ t &= 34 \text{ mm (1.33 in.)}. \end{aligned}$$

### P.9.2 SOLUTION

**P.9.2.1** Calculate the stiffness coefficients for the nozzle-tank connection:

$$\begin{aligned} R/t &= 40,000/34 = 1176 \quad (1560/1.33 = 1173) \\ a/R &= 305/40,000 = 0.008 \quad (12/1560 = 0.008) \\ L/2a &= 630/610 \cong 1.0 \quad (24.75/24 \cong 1.0) \end{aligned}$$

For the radial load (from Figure P-2G),

In SI units:

$$\begin{aligned} \frac{K_R}{E(2a)} &= 3.1 \times 10^{-4} \\ K_R &= (3.1 \times 10^{-4})(199,000 \text{ N/mm}^2)(610 \text{ mm}) \\ &= 37.6 \text{ N/mm} \end{aligned}$$

In US Customary units:

$$\begin{aligned} \frac{K_R}{E(2a)} &= 3.1 \times 10^{-4} \\ K_R &= (3.1 \times 10^{-4})(28.8 \times 10^6 \text{ lb/in.}^2)(24 \text{ in.}) \\ &= 214 \times 10^3 \text{ lbf/in.} \end{aligned}$$

For the longitudinal moment (from Figure P-2H),

In SI units:

$$\begin{aligned} \frac{K_L}{E(2a)^3} &= 3.0 \times 10^{-4} \\ K_L &= (3.0 \times 10^{-4})(199,000 \text{ N/mm}^2)(610 \text{ mm}) \\ &= 13.6 \times 10^9 \text{ N-mm/rad} \end{aligned}$$

In US Customary units:

$$\begin{aligned} \frac{K_L}{E(2a)^3} &= 3.0 \times 10^{-4} \\ K_L &= (3.0 \times 10^{-4})(28.8 \times 10^6)(24)^3 \\ &= 119 \times 10^6 \text{ in.-lb/rad} \end{aligned}$$

For the circumferential moment (from Figure P-2I),

In SI units:

$$\begin{aligned} \frac{K_C}{E(2a)^3} &= 5.0 \times 10^{-4} \\ K_C &= (5.0 \times 10^{-4})(199,000 \text{ N/mm}^2)(610 \text{ mm})^3 \\ &= 22.6 \times 10^9 \text{ N-mm/rad} \end{aligned}$$

In US Customary units:

$$\begin{aligned} \frac{K_C}{E(2a)^3} &= 5.0 \times 10^{-4} \\ K_C &= (5.0 \times 10^{-4})(28.8 \times 10^6)(24)^3 \\ &= 199 \times 10^6 \text{ in.-lb/rad} \end{aligned}$$

**P.9.2.2** Calculate the unrestrained shell deflection and rotation at the nozzle centerline resulting from the hydrostatic head of the full tank:

In SI units:

$$\beta = \frac{1.285}{(Rt)^{0.5}} = \frac{1.285}{(40,000 \times 34)^{0.5}} = 0.00110 \text{ mm}^{-1}$$

$$\beta L = (0.00110)(630) = 0.7 \text{ rad}$$

$$\begin{aligned} W &= \frac{9.8 \times 10^{-6} GHR^2}{Et} \left[ 1 - e^{-\beta L} \cos(\beta L) - \frac{L}{H} \right] + \alpha R \Delta T \\ &= \frac{(9.8 \times 10^{-6})(1)(19,200)(40,000)^2}{(199,000)(34)} \end{aligned}$$

$$\begin{aligned} &\left[ 1 - e^{-0.7} \cos(0.7) - \frac{630}{19,200} \right] + (12.0 \times 10^{-6})(40,000)(70) \\ &= 59.77 \text{ mm} \end{aligned}$$

oo

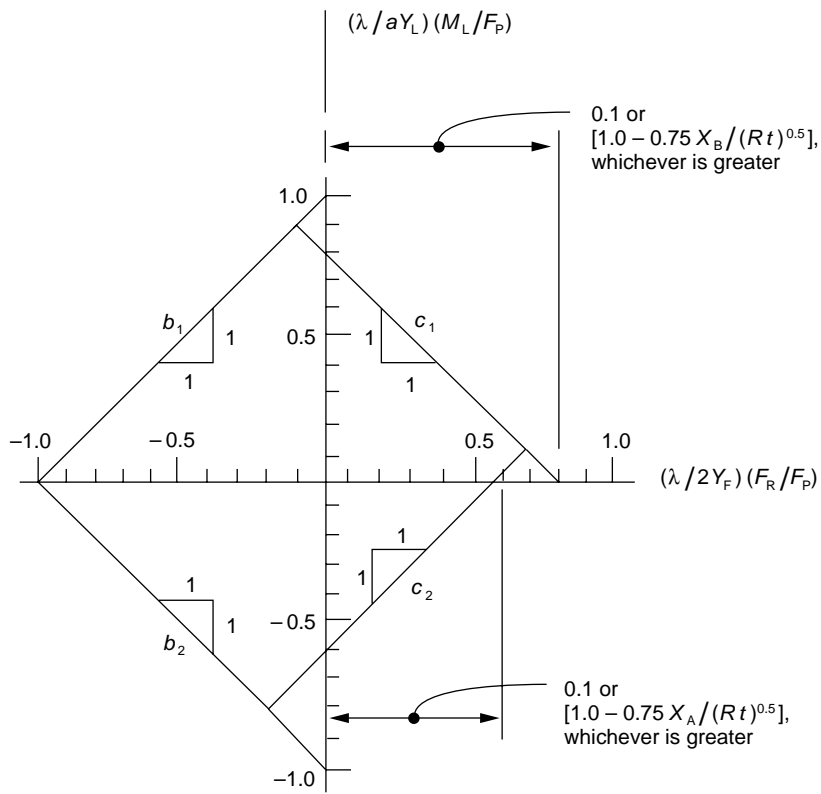

Figure P-3A—Construction of Nomogram for  $b_1$ ,  $b_2$ ,  $c_1$ ,  $c_2$  Boundary

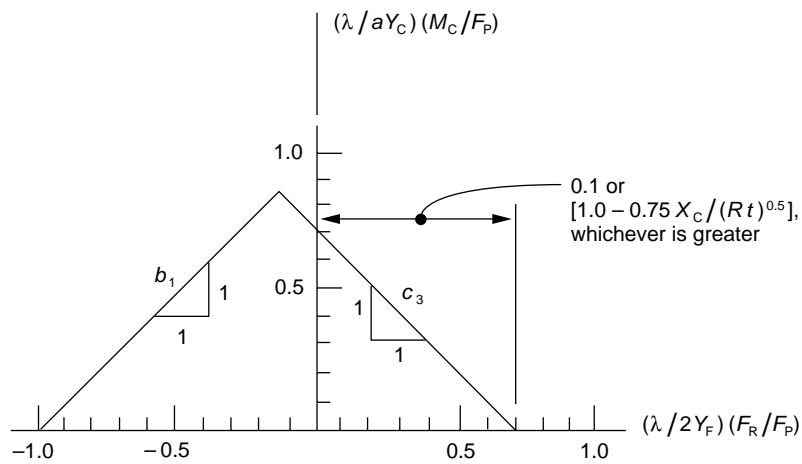

Figure P-3B—Construction of Nomogram for  $b_1$ ,  $c_3$  Boundary

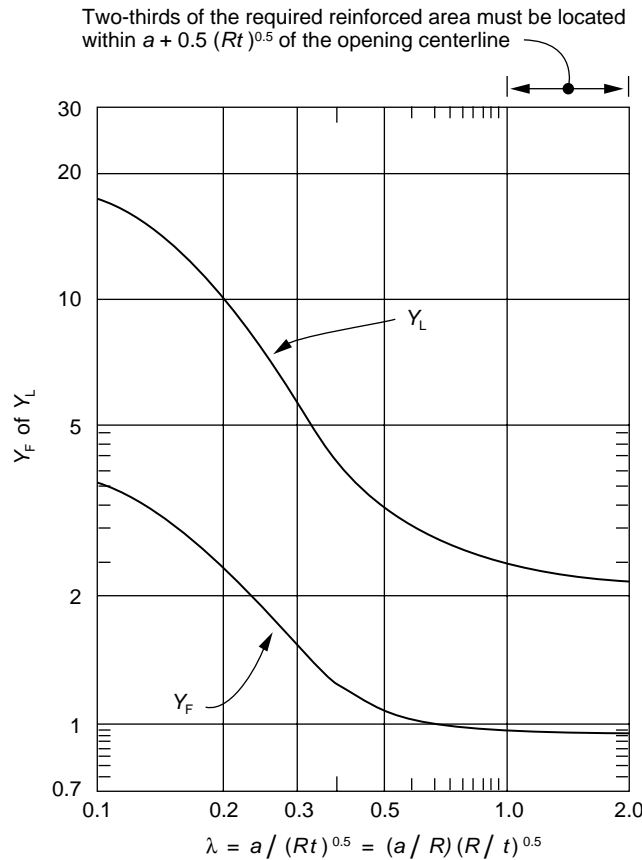

Figure P-4A—Obtaining Coefficients  $Y_F$  and  $Y_L$

$$\theta = \frac{9.8 \times 10^{-6} GHR^2}{Et} \left\{ \frac{1}{H} - \beta e^{-\beta L} [\cos(\beta L) + \sin(\beta L)] \right\} = \frac{0.036(1)(768)(1560)^2}{(28.8 \times 10^6)(1.33)} \left[ 1 - e^{-0.7} \cos(0.7) - \frac{24.75}{768} \right]$$

$$= \frac{(9.8 \times 10^{-6})(1)(19,200)(40,000)^2}{(199,000)(34)} = 2.39 \text{ inches}$$

$$\left\{ \frac{1}{19,200} - 0.0011 e^{-0.7} [\cos(0.7) + \sin(0.7)] \right\}$$

$$= -0.032 \text{ rad}$$

$$\theta = \frac{0.036 GHR^2}{Et} \left\{ \frac{1}{H} - \beta e^{-\beta L} [\cos(\beta L) + \sin(\beta L)] \right\}$$

$$= \frac{0.036(1)(768)(1560)^2}{(28.8 \times 10^6)(1.33)} \left[ \frac{1}{768} - \beta e^{-0.7} [\cos(0.7) + \sin(0.7)] \right]$$

$$= -0.032 \text{ rad}$$

In US Customary units:

$$\beta = \frac{1.285}{(Rt)^{0.5}} = \frac{1.285}{(1560 \times 1.33)^{0.5}} = 0.0282 \text{ in.}$$

$$\beta L = (0.0282)(24.75) = 0.7$$

$$W = \frac{0.036 GHR^2}{Et} \left[ 1 - e^{-\beta L} \cos(\beta L) - \frac{L}{H} \right] + \alpha R \Delta T$$

Perform the analysis of piping flexibility using  $W$ ,  $\theta$ ,  $K_R$ ,  $K_L$ , and  $K_C$  as the end conditions at the nozzle-to-piping connection.

$$X_A = 935 \text{ mm (36.75 in.)}$$

$$X_B = 325 \text{ mm (12.75 in.)}$$

$$X_C = 630 \text{ mm (24.75 in.)}$$

Determine the allowable loads for the shell opening, as in P.9.2.3.

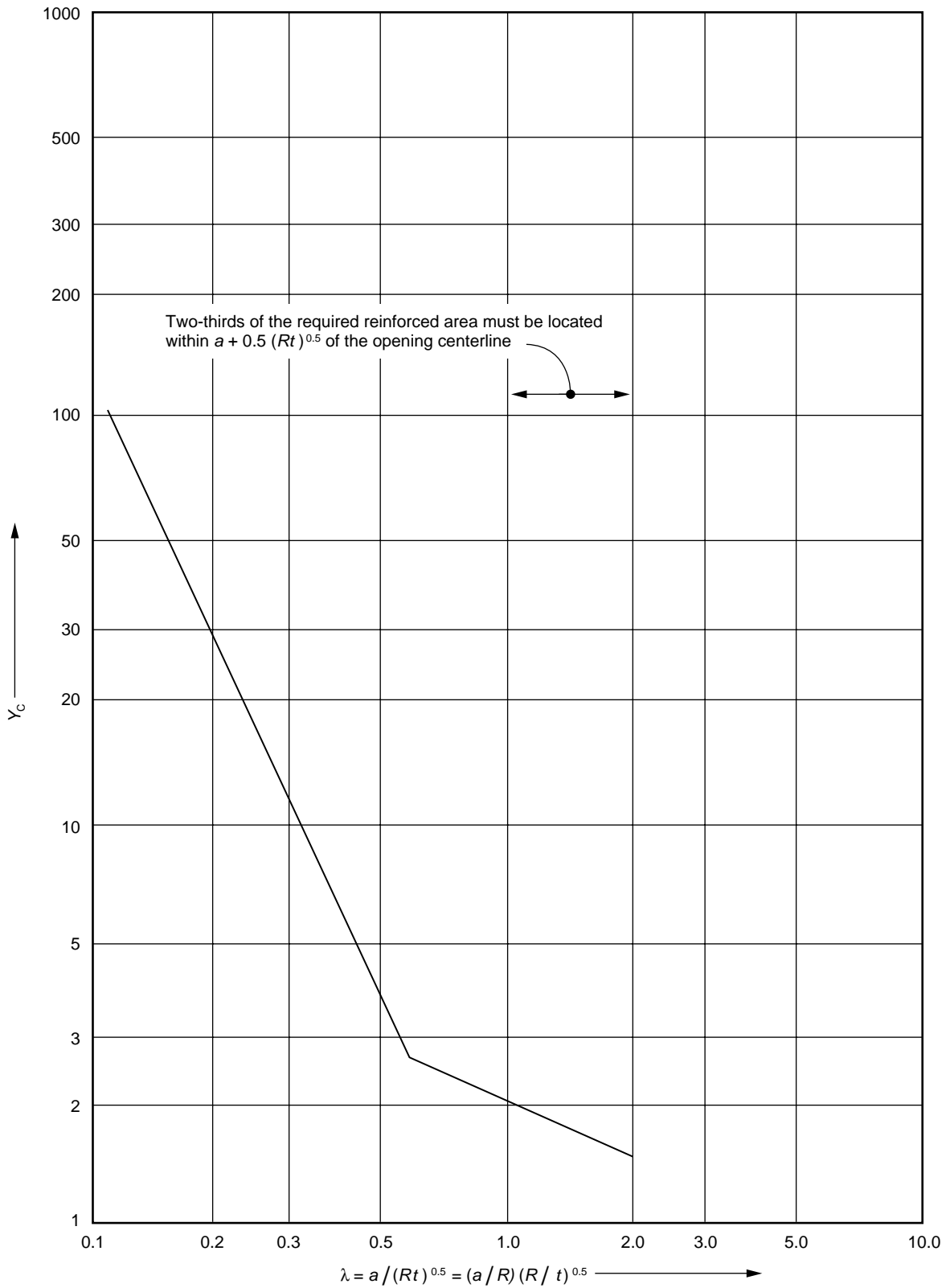

Figure P-4B—Obtaining Coefficient  $Y_C$

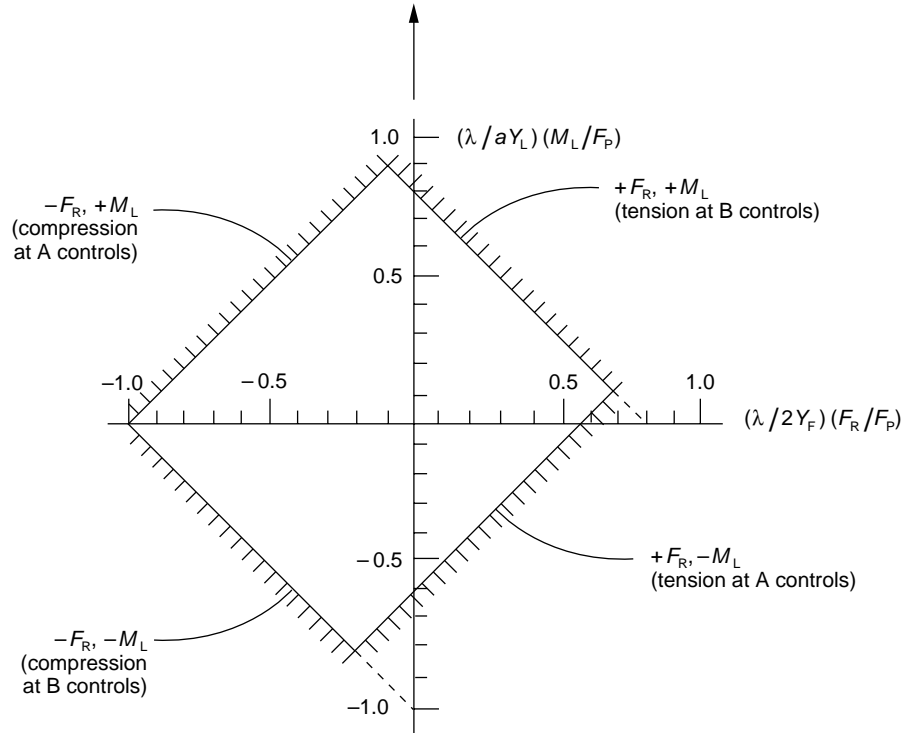

Figure P-5A—Determination of Allowable Loads from Nomogram:  $F_R$  and  $M_L$

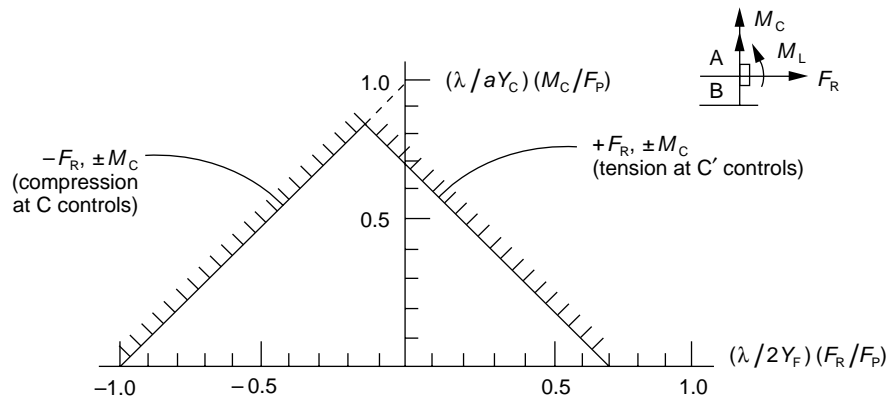

Figure P-5B—Determination of Allowable Loads from Nomogram:  $F_R$  and  $M_C$

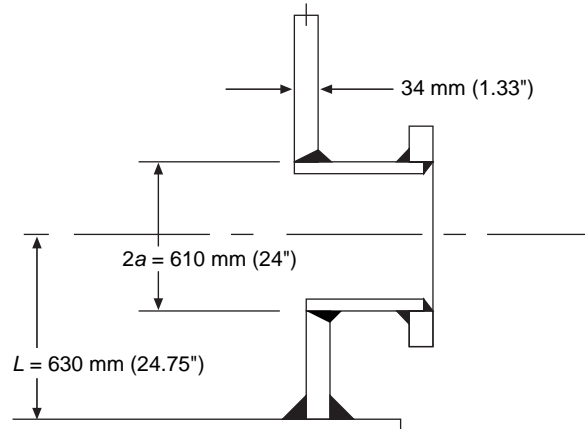

Figure P-6—Low-Type Nozzle with Reinforcement in Nozzle Neck Only (for Sample Problem)

**P.9.2.3** Determine the nondimensional quantities:

In SI units:

$$\frac{X_A}{(Rt)^{0.5}} = \frac{935}{[(40,000)(34)]^{0.5}} = 0.80$$

$$\frac{X_B}{(Rt)^{0.5}} = \frac{325}{[(40,000)(34)]^{0.5}} = 0.28$$

$$\frac{X_C}{(Rt)^{0.5}} = \frac{630}{[(40,000)(34)]^{0.5}} = 0.54$$

$$\lambda = \frac{A}{(Rt)^{0.5}} = \frac{305}{[(40,000)(34)]^{0.5}} = 0.26$$

In US Customary units:

$$\frac{X_A}{(Rt)^{0.5}} = \frac{36.75}{[(1560)(1.33)]^{0.5}} = 0.81$$

$$\frac{X_B}{(Rt)^{0.5}} = \frac{12.75}{[(1560)(1.33)]^{0.5}} = 0.28$$

$$\frac{X_C}{(Rt)^{0.5}} = \frac{24.75}{[(1560)(1.33)]^{0.5}} = 0.54$$

$$\lambda = \frac{A}{(Rt)^{0.5}} = \frac{12}{[(1560)(1.33)]^{0.5}} = 0.26$$

From Figures P-4A and P-4B,

$$Y_L = 7.8 \text{ mm (in.)}$$

$$Y_F = 2.0 \text{ mm (in.)}$$

$$Y_C = 15.0 \text{ mm (in.)}$$

**P.9.2.4** Construct the load nomograms (see Figure P-7):

In SI units:

$$1.0 - 0.75 \frac{X_B}{(Rt)^{0.5}} = 1.0 - 0.75 \left( \frac{325}{1166} \right) = 0.79$$

$$1.0 - 0.75 \frac{X_A}{(Rt)^{0.5}} = 1.0 - 0.75 \left( \frac{935}{1166} \right) = 0.40$$

$$1.0 - 0.75 \frac{X_C}{(Rt)^{0.5}} = 1.0 - 0.75 \left( \frac{630}{1166} \right) = 0.59$$

$$F_P = P\pi a^2 = (9800)(1.0)(19.2 - 0.630)\pi(0.305)^2 = 53,200 \text{ N}$$

$$\frac{\lambda}{2Y_F} \left( \frac{F_R}{F_P} \right) = \frac{0.26}{(2)(2.0)} \left( \frac{F_R}{53,200} \right) = 1.22 \times 10^{-6} F_R$$

$$\frac{\lambda}{aY_L} \left( \frac{M_L}{F_P} \right) = \frac{0.26}{(305)(7.8)} \left( \frac{M_L}{53,200} \right) = 2.05 \times 10^{-9} M_L$$

$$\frac{\lambda}{aY_C} \left( \frac{M_C}{F_P} \right) = \frac{0.26}{(305)(15)} \left( \frac{M_C}{53,200} \right) = 1.07 \times 10^{-9} M_C$$

In US Customary units:

$$1.0 - 0.75 \frac{X_B}{(Rt)^{0.5}} = 1.0 - 0.75 \left( \frac{12.75}{45.6} \right) = 0.79$$

$$1.0 - 0.75 \frac{X_A}{(Rt)^{0.5}} = 1.0 - 0.75 \left( \frac{36.75}{45.6} \right) = 0.40$$

$$1.0 - 0.75 \frac{X_C}{(Rt)^{0.5}} = 1.0 - 0.75 \left( \frac{24.75}{45.6} \right) = 0.59$$

$$F_P = P\pi a^2 = \left[ \frac{(62.4)(1.0)}{1728} \right] [(64)(12) - 24.75] \pi 12^2$$

$$= 12,142 \text{ pounds}$$

$$\frac{\lambda}{2Y_F} \left( \frac{F_R}{F_P} \right) = \frac{0.26}{(2)(2.0)} \left( \frac{F_R}{12,142} \right) = 5.35 \times 10^{-6} F_R$$

$$\frac{\lambda}{aY_L} \left( \frac{M_L}{F_P} \right) = \frac{0.26}{(12)(7.8)} \left( \frac{M_L}{12,142} \right) = 229 \times 10^{-9} M_L$$

$$\frac{\lambda}{aY_C} \left( \frac{M_C}{F_P} \right) = \frac{0.26}{(12)(15)} \left( \frac{M_C}{12,142} \right) = 119 \times 10^{-9} M_C$$

### P.9.2.5 Determine the limit piping loads.

For  $M_L = 0$  and  $M_C = 0$ ,

$$\frac{\lambda}{2Y_F} \left( \frac{F_R}{F_P} \right) = 5.35 \times 10^{-6} F_R \leq 0.4$$

$$\frac{\lambda}{2Y_F} \left( \frac{F_R}{F_P} \right) = 1.22 \times 10^{-6} F_R \leq 0.4$$

Therefore,

$$F_{Rmax} = \frac{0.4}{1.22 \times 10^{-6}} = 328,000 \text{ N (tension at A controls)}$$

$$F_{Rmax} = \frac{0.4}{5.35 \times 10^{-6}} = 74,800 \text{ pounds (tension at A controls)}$$

For  $M_L = 0$  and  $F_R = 0$ ,

$$\frac{\lambda}{aY_C} \left( \frac{M_C}{F_P} \right) = 1.07 \times 10^{-9} M_C \leq 0.59$$

$$\frac{\lambda}{aY_C} \left( \frac{M_C}{F_P} \right) = 119 \times 10^{-9} M_C \leq 0.59$$

Therefore,

$$M_{Cmax} = \frac{0.59}{1.07 \times 10^{-9}} = 550 \times 10^6 \text{ N-mm (tension at C' controls)}$$

$$M_{Cmax} = \frac{0.59}{1.19 \times 10^{-7}} = 4.95 \times 10^6 \text{ in.-lbs (tension at C' controls)}$$

For  $F_R = 0$  and  $M_C = 0$ ,

$$\frac{\lambda}{aY_L} \left( \frac{M_L}{F_P} \right) = 2.05 \times 10^{-9} M_L \leq 0.4$$

$$\frac{\lambda}{aY_L} \left( \frac{M_L}{F_P} \right) = 229 \times 10^{-9} M_L \leq 0.4$$

Therefore,

$$M_{Lmax} = \frac{0.4}{2.05 \times 10^{-9}} = 195 \times 10^6 \text{ N-mm (tension at A controls)}$$

$$M_{Lmax} = \frac{0.4}{2.3 \times 10^{-7}} = 1.74 \times 10^6 \text{ in.-lbs (tension at A controls)}$$

### P.9.3 SUMMARY

The limit piping loads are as follows:

In SI units:

$$F_{Rmax} = 328,000 \text{ N (tension at A controls)}$$

$$M_{Cmax} = 550 \times 10^6 \text{ N-mm (tension at C' controls)}$$

$$M_{Lmax} = 195 \times 10^6 \text{ N-mm (tension at A controls)}$$

In US Customary units:

$$F_{Rmax} = 74,800 \text{ pounds (tension at A controls)}$$

$$M_{Cmax} = 4.95 \times 10^6 \text{ in.-lbs (tension at C' controls)}$$

$$M_{Lmax} = 1.74 \times 10^6 \text{ in.-lbs (tension at A controls)}$$

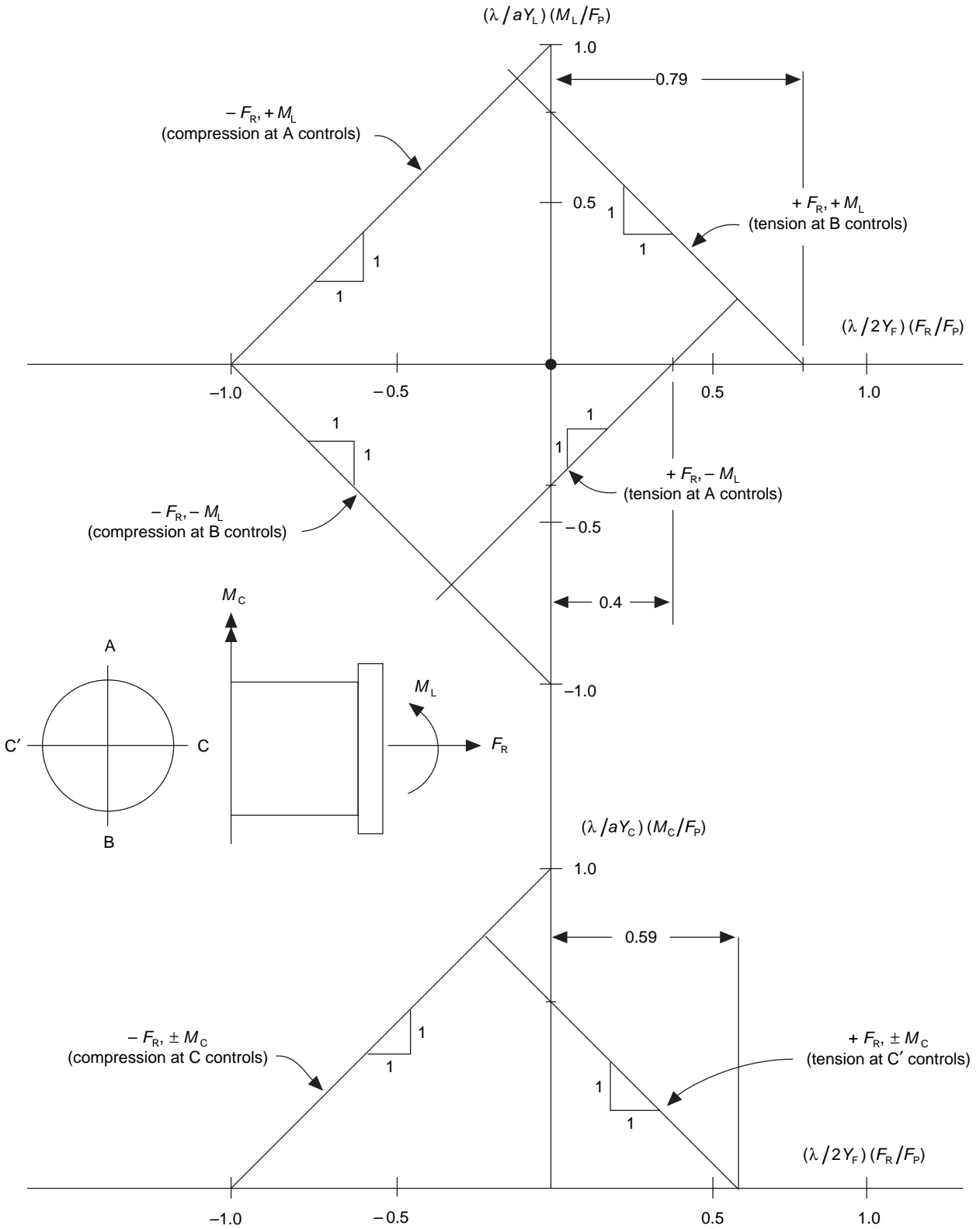

Figure P-7—Allowable-Load Nomograms for Sample Problem



## APPENDIX S—AUSTENITIC STAINLESS STEEL STORAGE TANKS

### S.1 Scope

**S.1.1** This appendix covers materials, design, fabrication, erection, and testing requirements for vertical, cylindrical, aboveground, closed- and open-top, welded, austenitic stainless steel storage tanks constructed of material grades 304, 304L, 316, 316L, 317, and 317L. This appendix does not cover stainless steel clad plate or strip lined construction.

- **S.1.2** This appendix applies only to tanks in nonrefrigerated services with a maximum operating temperature not exceeding 260°C (500°F). For the purposes of this appendix, the design temperature shall be the maximum operating temperature as specified by the purchaser. Ambient temperature tanks (non-heated) shall have a design temperature of 40°C (100°F). It is cautioned that exothermic reactions occurring inside unheated storage tanks can produce temperatures exceeding 40°C (100°F).

**S.1.3** This appendix is intended to provide the petroleum industry, chemical industry, and other users with tanks of safe design for containment of fluids within the design limits.

**S.1.4** The minimum thicknesses in this appendix do not contain any allowance for corrosion.

**S.1.5** This appendix states only the requirements that differ from the basic rules in this standard. For requirements not stated, the basic rules must be followed.

### S.2 Materials

#### S.2.1 SELECTION AND ORDERING

**S.2.1.1** Materials shall be in accordance with Table S-1.

- **S.2.1.2** Selection of the type/grade of stainless steel depends on the service and environment to which it will be exposed and the effects of fabrication processes. (See S.4.3.2 and S.4.4.3) The purchaser shall select the type/grade.

Table S-1a—ASTM Materials for Stainless Steel Components (SI units)

Plates and Structural Members (Note 1)	Piping and Tubing Seamless or Welded (Note 2)	Forgings (Notes 2, 3)	Bolting and Bars (Notes 4, 5)
A 240M, Type 304	A 213M, Grade TP 304	A 182M, Grade F 304	A 193M, Class 1, Grades B8, B8A, and B8M
A 240M, Type 304L	A 213M, Grade TP 304L	A 182M, Grade F 304L	A 194M, Grades B8, B8A, B8M, and B8MA
A 240M, Type 316	A 213M, Grade TP 316	A 182M, Grade F 316	A 320M, Grades B8, B8A, B8M, and B8MA
A 240M, Type 316L	A 213M, Grade TP 316L	A 182M, Grade F 316L	A 479M, Type 304
A 240M, Type 317	A 213M, Grade TP 317	A 182M, Grade F 317	A 479M, Type 304L
A 240M, Type 317L	A 213M, Grade TP 317L	A 182M, Grade F 317L	A 479M, Type 316
	A 312M, Grade TP 304		A 479M, Type 316L
	A 312M, Grade TP 304L		A 479M, Type 317
	A 312M, Grade TP 316		
	A 312M, Grade TP 316L		
	A 312M, Grade TP 317		
	A 312M, Grade TP 317L		
	A 358M, Grade 304		
	A 358M, Grade 304L		
	A 358M, Grade 316		
	A 358M, Grade 316L		
	A 403M, Class WP 304		
	A 403M, Class WP 304L		
	A 403M, Class WP 316		
	A 403M, Class WP 316L		
	A 403M, Class WP 317		
	A 403M, Class WP 317L		

Notes:

- 1. Unless otherwise specified by the purchaser, plate, sheet, or strip shall be furnished with a No. 1 finish and shall be hot-rolled, annealed, and descaled.
- 2. Carbon steel flanges and/or stub ends may be used by agreement between the purchaser and manufacturer, providing the design and details consider the dissimilar properties of the materials used and are suitable for the intended service.
- 3. Castings shall not be used unless specified by the purchaser. If specified, castings shall meet ASTM A 351 and shall be inspected in accordance with *ASME Boiler and Pressure Vessel Code*, Section VIII, Division 1, Appendix 7.
- 4. All bars in contact with the product shall be furnished in the hot-rolled, annealed, and descaled condition.
- 5. Other bolting materials may be used by agreement between the purchaser and manufacturer.

Table S-1b—ASTM Materials for Stainless Steel Components (US Customary units)

Plates and Structural Members (Note 1)	Piping and Tubing Seamless or Welded (Note 2)	Forgings (Notes 2, 3)	Bolting and Bars (Notes 4, 5)
A 240, Type 304	A213, Grade TP 304	A 182, Grade F 304	A 193, Class 1, Grades B8, B8A, and B8M
A 240, Type 304L	A213, Grade TP 304L	A 182, Grade F 304L	A 194, Grades 8, 8A, 8M, and 8MA
A 240, Type 316	A213, Grade TP 316	A 182, Grade F 316	A320, Grades B8, B8A, B8M, and B8MA
A 240, Type 316L	A213, Grade TP 316L	A 182, Grade F 316L	A 479, Type 304
A 240, Type 317	A213, Grade TP 317	A 182, Grade F 317	A 479, Type 304L
A 240, Type 317L	A213, Grade TP 317L	A 182, Grade F 317L	A 479, Type 316
A 276, Type 304	A 312, Grade TP 304		A 479, Type 316L
A 276, Type 304L	A 312, Grade TP 304L		A 479, Type 317
A 276, Type 316	A 312, Grade TP 316		
A 276, Type 316L	A 312, Grade TP 316L		
A 276, Type 317	A 312, Grade TP 317		
	A 312, Grade TP 317L		
	A 358, Grade 304		
	A 358, Grade 304L		
	A 358, Grade 316		
	A 358, Grade 316L		
	A 403, Class WP 304		
	A 403, Class WP 304L		
	A 403, Class WP 316		
	A 403, Class WP 316L		
	A 403, Class WP 317		
	A 403, Class WP 317L		

## Notes:

- 1. Unless otherwise specified by the purchaser, plate, sheet, or strip shall be furnished with a No. 1 finish and shall be hot-rolled, annealed, and descaled.
- 2. Carbon steel flanges and/or stub ends may be used by agreement between the purchaser and manufacturer, providing the design and details consider the dissimilar properties of the materials used and are suitable for the intended service.
- 3. Castings shall not be used unless specified by the purchaser. If specified, castings shall meet ASTM A 351 and shall be inspected in accordance with *ASME Boiler and Pressure Vessel Code*, Section VIII, Division 1, Appendix 7.
- 4. All bars in contact with the product shall be furnished in the hot-rolled, annealed, and descaled condition.
- 5. Other bolting materials may be used by agreement between the purchaser and manufacturer.

**S.2.1.3** External structural attachments may be carbon steels meeting the requirements of Section 2 of this standard, providing they are protected from corrosion and the design and details consider the dissimilar properties of the materials used. (This does not include shell, roof, or bottom openings and their reinforcement.) Carbon steel attachments (e.g., clips for scaffolding) shall not be welded directly to any internal surface of the tank.

### ● S.2.2 PACKAGING

Packaging stainless steel for shipment is important to its corrosion resistance. Precautions to protect the surface of the material will depend on the surface finish supplied and may vary among manufacturers. Normal packaging methods may

not be sufficient to protect the material from normal shipping damage. If the intended service requires special precautions, special instructions should be specified by the purchaser.

### S.2.3 IMPACT TESTING

Impact tests are not required for austenitic stainless steel base metals.

## S.3 Design

### S.3.1 BOTTOM PLATES

All bottom plates shall have a minimum nominal thickness of 5 mm (<sup>3</sup>/<sub>16</sub> in.), exclusive of any corrosion allowance.

### S.3.2 SHELL DESIGN

The required minimum thickness of shell plates shall be the greater of the values computed by the following formulas and the shell thickness shall not be less than the nominal plate thickness listed in 3.6.1.1:

In SI units:

$$t_d = \frac{4.9D(H-0.3)G}{(S_d)E} + CA$$

$$t_t = \frac{4.9D(H-0.3)}{(S_t)(E)}$$

where

$t_d$  = design shell thickness (mm),

$t_t$  = hydrostatic test shell thickness (mm),

$D$  = nominal diameter of tank (m) (see 3.6.1.1),

$H$  = design liquid level (m) (see 3.6.3.2),

- $G$  = specific gravity of the liquid to be stored, as specified by the purchaser,

$E$  = joint efficiency, 1.0, 0.85, or 0.70 (see Table S-4),

- $CA$  = corrosion allowance (mm), as specified by the purchaser (see 3.3.2),

$S_d$  = allowable stress for the design condition (MPa) (see Table S-2),

$S_t$  = allowable stress for hydrostatic test condition (MPa) (see Table S-2).

In US Customary units:

$$t_d = \frac{2.6D(H-1)G}{(S_d)E} + CA$$

$$t_t = \frac{2.6D(H-1)}{(S_t)(E)}$$

where

$t_d$  = design shell thickness (in.),

$t_t$  = hydrostatic test shell thickness (in.),

$D$  = nominal diameter of tank (ft) (see 3.6.1.1),

$H$  = design liquid level (ft) (see 3.6.3.2),

- $G$  = specific gravity of the liquid to be stored, as specified by the purchaser,

$E$  = joint efficiency, 1.0, 0.85, or 0.70 (see Table S-4),

- $CA$  = corrosion allowance (in.), as specified by the purchaser (see 3.3.2),

$S_d$  = allowable stress for the design condition (lbf/in.<sup>2</sup>) (see Table S-2),

$S_t$  = allowable stress for hydrostatic test condition (lbf/in.<sup>2</sup>) (see Table S-2).

Note: The allowable stresses recognize the increased toughness of stainless steels over carbon steels and the relatively low yield/tensile ratios of the stainless steels. The increased toughness permits designing to a higher proportion of the yield strength, however, the manufacturer and purchaser shall be aware that this may result in permanent strain (see Table S-2).

### S.3.3 SHELL OPENINGS

**S.3.3.1** The minimum nominal thickness of connections and openings shall be as follows:

Size of Nozzle	Minimum Nominal Neck Thickness
NPS 2 and less	Schedule 80S
NPS 3 and NPS 4	Schedule 40S
Over NPS 4	6 mm (0.25 in.)

Note: Reinforcement requirements of 3.7 must be maintained.

**S.3.3.2** Thermal stress relief requirements of 3.7.4 are not applicable.

**S.3.3.3** Shell manholes shall be in conformance with 3.7.5 except that the minimum thickness requirements shall be multiplied by the greater of (a) the ratio of the material yield strength at 40°C (100°F) to the material yield strength at the design temperature, or (b) the ratio of 205 MPa (30,000 psi) to the material yield strength at the design temperature.

**S.3.3.4** As an alternative to S.3.3.3, plate ring flanges may be designed in accordance with API Standard 620 rules using the allowable stresses given in Table S-3.

### S.3.4 ROOF MANHOLES

All stainless steel components of the roof manhole shall have a minimum thickness of 5 mm (<sup>3</sup>/<sub>16</sub> in.).

### S.3.5 APPENDIX F—MODIFICATIONS

**S.3.5.1** In F.4.1 and F.5.1, the value of 212 MPa (30,800 psi) shall be multiplied by the ratio of the material yield strength at the design temperature to 220 MPa (32,000 psi). (See Table S-5 for yield strength.)

**S.3.5.2** In F.7.1, the shell thickness shall be as specified in S.3.2 except that the pressure  $P$  [in kPa (in. of water)] divided by 9.8 $G$  (12 $G$ ) shall be added to the design liquid height in meters (ft). The maximum joint efficiency shall be 0.85.

**S.3.5.3** In F.7.2, the allowable compressive stress of 140 MPa (20,000 psi) shall be multiplied by the ratio of the material yield stress at the design temperature to 220 MPa (32,000 psi). (See Table S-5 for yield strengths.)

### S.3.6 APPENDIX M—MODIFICATIONS

**S.3.6.1** Appendix M requirements shall be met for stainless steel tanks with design temperatures over 40°C (100°F) as modified by S.3.6.2 through S.3.6.7.

**S.3.6.2** Allowable shell stress shall be in accordance with Table S-2.

**S.3.6.3** In M.3.4, the requirements of 3.7.7 for flush-type cleanout fittings and of 3.7.8 for flush-type shell connections shall be modified. The thickness of the bottom reinforcing plate, bolting flange, and cover plate shall be multiplied by the greater of (a) the ratio of the material yield strength at 40°C (100°F) to the material yield strength at the design temperature, or (b) the ratio of 205 MPa (30,000 psi) to the material yield strength at the design temperature. (See Table S-5 for yield strength.)

**S.3.6.4** In M.3.5, the stainless steel structural allowable stress shall be multiplied by the ratio of the material yield strength at the design temperature to the material yield strength at 40°C (100°F). (See Table S-5 for yield strength.)

**S.3.6.5** The requirements of M.3.6 and M.3.7 are to be modified per S.3.5.1.

**S.3.6.6** In M.5.1, the requirements of 3.10.5 and 3.10.6 shall be multiplied by the ratio of the material modulus of elasticity at 40°C (100°F) to the material modulus of elasticity at the design temperature. (See Table S-6 for modulus of elasticity.)

**S.3.6.7** In M.6 (the equation for the maximum height of unstiffened shell in 3.9.7.1), the maximum height shall be multiplied by the ratio of the material modulus of elasticity at the design temperature to the material modulus of elasticity at 40°C (100°F).

## S.4 Fabrication and Construction

### S.4.1 GENERAL

Special precautions must be observed to minimize the risk of damage to the corrosion resistance of stainless steel. Stainless steel shall be handled so as to minimize contact with iron or other types of steel during all phases of fabrication and construction. The following sections describe the major precautions that should be observed during fabrication and handling.

### S.4.2 STORAGE

Storage should be under cover and well removed from shop dirt and fumes from pickling operations. If outside storage is necessary, provisions should be made for rainwater to drain and allow the material to dry. Stainless steel should not be stored in contact with carbon steel. Materials containing chlorides, including foods, beverages, oils, and greases, should not come in contact with stainless steel.

### S.4.3 THERMAL CUTTING

**S.4.3.1** Thermal cutting of stainless steel shall be by the iron powder burning carbon arc or the plasma-arc method.

- **S.4.3.2** Thermal cutting of stainless steel may leave a heat-affected zone and intergranular carbide precipitates. This heat-affected zone may have reduced corrosion resistance unless removed by machining, grinding, or solution annealing and quenching. The purchaser shall specify if the heat-affected zone is to be removed.

### S.4.4 FORMING

**S.4.4.1** Stainless steels shall be formed by a cold, warm, or hot forming procedure that is noninjurious to the material.

**S.4.4.2** Stainless steels may be cold formed, providing the maximum strain produced by such forming does not exceed 10% and control of forming spring-back is provided in the forming procedure.

- **S.4.4.3** Warm forming at 540°C (1000°F) to 650°C (1200°F) may cause intergranular carbide precipitation in 304, 316, and 317 grades of stainless steel. Unless stainless steel in this sensitized condition is acceptable for the service of the equipment, it will be necessary to use 304L, 316L, or 317L grades or to solution anneal and quench after forming. Warm forming shall be performed only with agreement of the purchaser.

**S.4.4.4** Hot forming, if required, may be performed within a temperature range of 900°C (1650°F) to 1200°C (2200°F).

**S.4.4.5** Forming at temperatures between 650°C (1200°F) and 900°C (1650°F) is not permitted.

### S.4.5 CLEANING

- **S.4.5.1** When the purchaser requires cleaning to remove surface contaminants that may impair the normal corrosion resistance, it shall be done in accordance with ASTM A380, unless otherwise specified. Any additional cleanliness requirements for the intended service shall be specified by the purchaser.

**S.4.5.2** When welding is completed, flux residues and weld spatter shall be removed mechanically using stainless steel tools.

**S.4.5.3** Removal of excess weld metal, if required, shall be done with a grinding wheel or belt that has not been previously used on other metals.

**S.4.5.4** Chemical cleaners used shall not have a detrimental effect on the stainless steel and welded joints and shall be disposed of in accordance with laws and regulations governing the disposal of such chemicals. The use of chemical cleaners shall always be followed by thorough rinsing with water and drying (see S.4.9).

Table S-2—Allowable Stresses for Tank Shells

Type	Min. Yield MPa (psi)	Min. Tensile MPa (psi)	Allowable Stress [in MPa (psi)] for Design Temperature Not Exceeding ( $S_d$ )					
			40°C (100°F)	90°C (200°F)	150°C (300°F)	200°C (400°F)	260°C (500°F)	$S_t$ Ambient
304	205 (30,000)	515 (75,000)	155 (22,500)	155 (22,500)	140 (20,300)	128 (18,600)	121 (17,500)	186 (27,000)
304L	170 (25,000)	485 (70,000)	145 (21,000)	132 (19,200)	119 (17,200)	109 (15,800)	101 (14,700)	155 (22,500)
316	205 (30,000)	515 (75,000)	155 (22,500)	155 (22,500)	145 (21,000)	133 (19,300)	123 (17,900)	186 (27,000)
316L	170 (25,000)	485 (70,000)	145 (21,000)	131 (19,000)	117 (17,000)	107 (15,500)	99 (14,300)	155 (22,500)
317	205 (30,000)	515 (75,000)	155 (22,500)	155 (22,500)	145 (21,000)	133 (19,300)	123 (17,900)	186 (27,000)
317L	205 (30,000)	515 (75,000)	155 (22,500)	155 (22,500)	145 (21,000)	133 (19,300)	123 (17,900)	186 (27,000)

## Notes:

- $S_d$  may be interpolated between temperatures.
- The design stress shall be the lesser of 0.3 of the minimum tensile strength or 0.9 of the minimum yield strength. The factor of 0.9 of yield corresponds to a permanent strain of 0.10%. When a lower level of permanent strain is desired, the purchaser shall specify a reduced yield factor in accordance with Table Y-2 of ASME Section II, Part D. The yield values at the different design temperatures can be obtained from Table S-5.
- For dual certified materials (e.g., ASTM A 182M/A 182 Type 304L/304), use the allowable stress of the grade specified by the purchaser.

Table S-3—Allowable Stresses for Plate Ring Flanges

Type	Allowable Stress [in MPa (psi)] for Design Temperature Not Exceeding				
	40°C (100°F)	90°C (200°F)	150°C (300°F)	200°C (400°F)	260°C (500°F)
304	140 (20,000)	115 (16,700)	103 (15,000)	95 (13,800)	89 (12,900)
304L	117 (16,700)	99 (14,300)	88 (12,800)	81 (11,700)	75 (10,900)
316	140 (20,000)	119 (17,200)	107 (15,500)	99 (14,300)	92 (13,300)
316L	117 (16,700)	97 (14,100)	87 (12,600)	79 (11,500)	73 (10,600)
317	140 (20,000)	119 (17,300)	108 (15,600)	99 (14,300)	92 (13,300)
317L	140 (20,000)	119 (17,300)	108 (15,600)	99 (14,300)	92 (13,300)

## Notes:

- Allowable stresses may be interpolated between temperatures.
- The allowable stresses are based on a lower level of permanent strain.
- The design stress shall be the lesser of 0.3 of the minimum tensile strength or  $2/3$  of the minimum yield strength.
- For dual certified materials (e.g., ASTM A 182M/A 182 Type 304L/304), use the allowable stress of the grade specified by the purchaser.

Table S-4—Joint Efficiencies

Joint Efficiency	Radiograph Requirements
1.0	Radiograph per 6.1.2
0.85	Radiograph per A.5.3
0.70	No radiography required

Table S-5—Yield Strength Values in MPa (psi)

Type	Yield Strength [in MPa (psi)] for Design Temperature Not Exceeding				
	40°C (100°F)	90°C (200°F)	150°C (300°F)	200°C (400°F)	260°C (500°F)
304	205 (30,000)	170 (25,000)	155 (22,500)	143 (20,700)	134 (19,400)
304L	170 (25,000)	148 (21,400)	132 (19,200)	121 (17,500)	113 (16,400)
316	205 (30,000)	178 (25,800)	161 (23,300)	148 (21,400)	137 (19,900)
316L	170 (25,000)	145 (21,100)	130 (18,900)	119 (17,200)	110 (15,900)
317	205 (30,000)	179 (25,900)	161 (23,400)	148 (21,400)	138 (20,000)
317L	205 (30,000)	179 (25,900)	161 (23,400)	148 (21,400)	138 (20,000)

Notes:

1. Interpolate between temperatures.
2. Reference: Table Y-1 of ASME Section II, Part D.

Table S-6—Modulus of Elasticity at the Maximum Operating Temperature

Design Temperature [C° (°F)] Not Exceeding	Modulus of Elasticity [MPa (psi)]
40 (100)	193,000 (28,000,000)
90 (200)	189,000 (27,400,000)
150 (300)	183,000 (26,600,000)
200 (400)	180,000 (26,100,000)
260 (500)	174,000 (25,200,000)

Note: Interpolate between temperatures.

#### S.4.6 BLAST CLEANING

If blast cleaning is necessary, it shall be done with sharp acicular grains of sand or grit containing not more than 2% by weight iron as free iron or iron oxide. Steel shot or sand used previously to clean nonstainless steel is not permitted.

#### S.4.7 PICKLING

If pickling of a sensitized stainless steel is necessary, an acid mixture of nitric and hydrofluoric acids shall not be used. After pickling, the stainless steel shall be thoroughly rinsed with water and dried.

#### S.4.8 PASSIVATION OR IRON FREEING

When passivation or iron freeing is specified by the purchaser, it may be achieved by treatment with nitric or citric acid. The use of hydrofluoric acid mixtures for passivation purposes is prohibited for sensitized stainless.

#### S.4.9 RINSING

**S.4.9.1** When cleaning and pickling or passivation is required, these operations shall be followed immediately by rinsing, not allowing the surfaces to dry between operations.

- **S.4.9.2** Rinse water shall be potable and shall not contain more than 200 parts per million chloride at temperatures below 40°C (100°F), or no more than 100 parts per million chloride at temperatures above 40°C (100°F) and below 65°C (150°F), unless specified otherwise by the purchaser.

**S.4.9.3** Following final rinsing, the equipment shall be completely dried.

#### S.4.10 HYDROSTATIC TEST CONSIDERATIONS—QUALITY OF TEST WATER

- **S.4.10.1** The materials used in the construction of stainless steel tanks may be subject to severe pitting, cracking, or rusting if they are exposed to contaminated test water for extended periods of time. The purchaser shall specify a minimum quality of test water that conforms to the following requirements:

- a. Unless otherwise specified by the purchaser, water used for hydrostatic testing of tanks shall be potable and treated, containing at least 0.2 parts per million free chlorine.
- b. Water shall be substantially clean and clear.
- c. Water shall have no objectionable odor (that is, no hydrogen sulfide).

- d. Water pH shall be between 6 and 8.3.
- 00 | e. Water temperature shall be below 50°C (120°F).
- f. The chloride content of the water shall be below 50 parts per million, unless specified otherwise by the purchaser.

- **S.4.10.2** When testing with potable water, the exposure time shall not exceed 21 days, unless specified otherwise by the purchaser.

**S.4.10.3** When testing with other fresh waters, the exposure time shall not exceed 7 days.

**S.4.10.4** Upon completion of the hydrostatic test, water shall be completely drained. Wetted surfaces shall be washed with potable water when nonpotable water is used for the test and completely dried. Particular attention shall be given to low spots, crevices, and similar areas. Hot air drying is not permitted.

#### **S.4.11 WELDING**

**S.4.11.1** Tanks and their structural attachments shall be welded by any of the processes permitted in 5.2.1.1 or by the plasma arc process. Galvanized components or components painted with zinc-rich paint shall not be welded directly to stainless steel.

**S.4.11.2** Filler metal chemistry shall match the type of base metals joined. Dissimilar welds to carbon steels shall use filler metals of E309 or higher alloy content.

#### **S.4.12 WELDING PROCEDURE AND WELDER QUALIFICATIONS**

- 98 | Impact tests are not required for austenitic stainless steel weld metal and heat-affected zones.

- **S.4.13 POSTWELD HEAT TREATMENT**

Postweld heat treatment of austenitic stainless steel materials need not be performed unless specified by the purchaser.

#### **S.4.14 INSPECTION OF WELDS**

##### **S.4.14.1 Radiographic Inspection of Butt-Welds**

Radiographic examination of butt-welds shall be in accordance with 6.1 and Table S-4.

##### **S.4.14.2 Inspection of Welds by Liquid Penetrant Method**

The following component welds shall be examined by the liquid penetrant method before the hydrostatic test of the tank:

- The shell-to-bottom inside attachment weld.
- All welds of opening connections in tank shell that are not completely radiographed, including nozzle and manhole neck welds and neck-to-flange welds.
- All welds of attachments to shells, such as stiffeners, compression rings, clips, and other nonpressure parts for which the thickness of both parts joined is greater than 19 mm (<sup>3</sup>/<sub>4</sub> in.).
- All butt-welded joints in tank shell and annular plate on which backing strips are to remain.

#### **S.5 Marking**

Brazing shall be deleted from 8.1.2.

#### **S.6 Appendices**

The following appendices are modified for use with austenitic stainless steel storage tanks:

- a. Appendix C is applicable; however, the purchaser shall identify all materials of construction.
- b. Appendix F is modified as outlined in S.3.5 of this appendix.
- c. Appendix J is applicable, except the minimum shell thickness for all tank diameters is 5 mm (<sup>3</sup>/<sub>16</sub> in.).
- d. Appendix K is not applicable to tanks built to this appendix.
- e. Appendix M is modified as outlined in S.3.6 of this appendix.
- f. Appendix N is not applicable.
- g. Appendix O is applicable; however, the structural members of Table O-1 shall be of an acceptable grade of material.
- h. All other appendices are applicable without modifications.



## APPENDIX T—NDE REQUIREMENTS SUMMARY

Process	Welds Requiring Inspection	Reference Section
Air Test	Reinforcement plate welds inside and outside to 100 kPa (15 lbf/in. <sup>2</sup> ).	5.3.5
Air Test	Roofs designed to be airtight if roof seams are not vacuum box tested.	5.3.7.1.a
Air Test	Drain pipe and hose systems of primary drains of external floating roofs.	C.4.5
Air Test	Appendix F tanks with anchors.	F.7.6
Air Test	Aluminum dome roofs if required to be gastight.	G.10.1.2
Air Test	Shop built tanks	J.4.2.2
Hydro	Tank shell.	5.3.6.a
MT	Flush-type shell connections: nozzle-to-tank shell, repad welds, shell-to-bottom reinforcing pad welds on the root pass, each 1/2 inch of weld, and completed weld. After stress relieving before hydro test.	3.7.8.11
MT	Permanent attachment welds and temporary weld removal areas.	5.2.3.5
MT	Welds attaching nozzles, manways, and clean out openings.	5.2.3.6
MT	First pass of the internal shell-to-bottom weld.	5.2.4.1.a
MT	Final shell-to-bottom welds, inside and outside instead of MT, PT, pen. oil, or VB of the initial inside pass.	5.2.4.2.c
Pen. Oil	All seams of internal floating roofs exposed to liquid or vapors.	H.4.3.4
Pen. Oil	First pass of the internal shell-to-bottom weld if approved instead of MT or PT.	5.2.4.1.d
Pen. Oil	Tank shell if no water for hydrostatic test.	5.3.6.b
Pen. Oil	Deck seams of external floating roofs.	C.4.2
PT	Permanent attachment welds and temporary weld removal areas instead of MT if approved.	5.2.3.5
PT	Welds attaching nozzles, manways, and clean out openings instead of MT if approved.	5.2.3.6
PT	First pass of the internal shell-to-bottom weld if approved instead of MT.	5.2.4.1.b or c
PT	Final shell-to-bottom welds, inside and outside instead of MT, PT, pen. oil, or VB of the initial inside pass.	5.2.4.2.c
PT	All aluminum structural welds and components joined by welding.	G.11.3
PT	Shell-to-bottom welds, opening connections not radiographed all welds of attachments to shells, and all butt welds of shell plates and annular plates of stainless steel tanks.	S.4.14.2
RT	Shell plate butt welds.	5.3.2.1
RT	Butt welds of annular plates that are required by 3.5.1 or M.4.1.	6.1.2.9
RT	Flush-type shell connections: 100% of all longitudinal butt welds in the nozzle neck and transition piece, if any, and the first circumferential butt weld in the neck closest to the shell, excluding the neck-to-flange weld.	3.7.8.11
Tracer Gas	Entire length of bottom weld joints as an alternative to vacuum box testing.	5.3.3.5
UT	When specified for weld examination.	6.3.1
VB	First pass of the internal shell-to-bottom weld if approved instead of MT, PT, or pen. oil.	5.2.4.1.e
VB	Final shell-to-bottom welds, inside and outside instead of MT, PT, pen. oil, or VB of the initial inside pass.	5.2.4.2.c
VB	Bottom welds.	5.3.4.a
VB	Welds of roofs designed to be gastight if not air tested.	5.3.7.1.b
VB	All seams of internal floating roofs exposed to liquid or vapors.	H.4.3.4
VB	Flexible membrane liners.	I.6.2
VE	Flush-type shell connections: nozzle-to-tank shell, repad welds, shell-to-bottom reinforcing pad welds on the root pass, each 20 mm (1/2 in.) of weld, and completed weld. After stress relieving before hydro test.	3.7.8.11
VE	Tack of shell butt welds left in place.	5.2.1.8
VE	Permanent attachment welds and temporary weld removal areas.	5.2.3.5
VE	Welds attaching nozzles, manways, and clean out openings.	5.2.3.6
VE	First pass of the internal shell-to-bottom weld.	5.2.4.1
VE	Final shell-to-bottom welds, inside and outside instead of MT, PT, pen. oil, or VB of the initial inside pass.	5.2.4.2.b
VE	Shell plate butt welds.	5.3.2.1

01

Process	Welds Requiring Inspection	Reference Section
VE	Fillet welds.	5.3.2.2
VE	Welds on roofs not designed to be gas tight.	5.3.7.2
VE	Upper side of the upper deck welds of pontoon and double deck floating roofs.	C.4.4
VE	All aluminum structural welds and components joined by welding	G.11.3
VE	Joint fit-up of butt welds of bottoms supported by grillage and each weld pass.	I.7.4
Water	Bottom welds if not vacuum box tested.	5.3.4.b
Water	External floating roofs—floating test.	C.4.3
Water	Aluminum dome roofs after completion.	G.10.1.1
Water	Internal floating roofs	H.7.3

## Definitions:

MT= Magnetic Particle Examination  
 Pen Oil = Penetrating Oil Test  
 PT = Liquid Penetrant Examination  
 RT = Radiographic Testing  
 VB = Vacuum Box Testing  
 VE = Visual Examination

## Acceptance Standards:

MT: ASME Section V, Article 7  
 PT: ASME Section V, Article 6, excluding aluminum dome parts—see AWS D1.2.  
 RT: ASME Section VIII, Paragraph UW-51(b)  
 Tracer Gas: None  
 UT: As agreed upon by purchaser and manufacturer.  
 VB: None  
 VE: API-650 6.5

## Examiner Qualifications:

MT: API 650, Section 6.2.3  
 PT: API 650, Section 6.2.3  
 RT: ASNT Level II or III  
 Tracer Gas: None  
 UT: ASNT Level II or III. A Level I may be used with restrictions—see API 650, Section 6.3.3.  
 VB: None  
 VE: None

## Procedure Requirements:

MT: ASME Section V, Article 7  
 PT: ASME Section V, Article 6  
 RT: A procedure is not required. However, the examination method must comply with ASME Section V, Article 2. Acceptance standards shall be in accordance with ASME Section VIII, Paragraph UW-51(b).  
 UT: ASME Section V, Article 5  
 VB: None  
 VE: None

01

## APPENDIX TI—TECHNICAL INQUIRY RESPONSES

Following are selected responses to requests for interpretation API Standard 650 requirements. A more extensive listing of interpretations can be found on the API website at <http://api-ep.api.org> under the “Standards” section. Additional information on technical inquiries can be found in Appendix D.

### SECTION 1.1 SCOPE

650-I-03/00

Question 1: Regarding the use of SI units, does API 650 allow either of the following?

- (1) Use of SI units throughout the design process.
- (2) Use the original U.S. Customary units with a hard conversion to SI units as a final step to the design process.

Reply 1: Yes, both are allowed.

Question 2: When SI units are used, does API 650 require different dimensional details compared to previous API 650 Editions or USC unit details now specified in the 10th Edition?

Reply 2: The committee currently has an agenda item to study this question. Any changes resulting from this agenda item will appear in a future addendum or edition to API 650.

Question 3: When SI units are used, does API 650 require material thickness, material properties, configurations, etc. based solely on the SI units for a particular tank?

Reply 3: The committee currently has an agenda item to study this question. Any changes resulting from this agenda item will appear in a future addendum or edition to API 650.

Question 4: Does the wording of the Foreword to API 650 require a separate check of the USC results when SI unit are specified and after making such a check using the USC results if more restrictive?

Reply 4: No.

### SECTION 2.2 PLATES

650-I-09/01

Question: For plate material certified by the manufacturer to meet more than one specification, such as A 516 Grade 60 and A 516 Grade 70, which specification should be used when applying the rules in Table 2-3, Figure 2-1, and Section 2.2.9 of API 650?

Reply: Dual certification of material is not addressed in API 650, except in Appendix S.

650-I-11/01

Question: Does API 650 require that the material in the bottom shell course and the annular plate be the same material specification?

Reply: API 650, Section 2.2.9.1, requires bottom plates welded to the shell to comply with Figure 2-1, but does not require the bottom shell course and annular plate to be the same material specification.

### SECTION 2.5 PIPING AND FORGINGS

650-I-15/00

Question: 1 For nozzles made from pipe materials, does API 650, Section 2.5.2 require that seamless pipe be used for nozzles in shells made from Group I, II, III, or IIIA materials?

Reply 1: Yes, unless ASTM A 671 pipe is used.

Question: 2: Does API 650, Section. 2.5.2 preclude the use of electric-resistance welded pipe meeting ASTM A 53, or electric-welded pipe meeting API 5L, for nozzles in shells made from Group IV, IVA, V, or VI materials, but allow use of electric-fusion-welded pipe nozzles made from ASTM A 671?

Reply 2: Yes.

### SECTION 3.5 ANNULAR BOTTOM PLATES

650-I-49/00

Question: If a tank bottom slopes downward toward the center of the tank, are the annular plates required to lap over the bottom plates?

Reply: This is not covered by API 650.

### SECTION 3.7 SHELL OPENINGS

650-I-33/99

Question: Referring to API 650, Section 3.7.4, must all flush-type cleanouts and flush-type shell connections be stress-relieved regardless of the material used, the nozzle diameter, or the thickness of the shell insert plate?

Reply: Yes, see Section 3.7.4.1.

650-I-53/99

Question 1: Per Section 3.7.4.2, for shell openings over NPS 12, if insert plates are not used to reinforce the shell opening, is the shell thickness a factor in determining if PWHT of the assembly is required?

Reply 1: Yes.

Question 2: Regarding Section 3.7.4.2, is stress-relieving mandatory for the prefabricated assembly when the thickness of the thickened insert plate exceeds 1 in., irrespective of the shell opening size?

Reply 2: No. The requirement applies only to NPS 12 or larger connections.

650-I-01/00

Question: Does API 650, Section 3.7.4.3, allow stress-relieving nozzles, as described therein, after installation in the shell, using locally applied heaters?

Reply: No. The heat treatment must be performed prior to installation in the tank.

650-I-18/00

Question 1: Referencing Figure 3-11, does API 650 cover flush shell connections to be installed non-radially?

Reply 1: No.

Question 2: Referencing Figure 3-12, are flush-type shell connections smaller than 8 in. covered in API 650?

Reply 2: No.

650-I-34/00

Question: Does API 650, Section 3.7.4.2 require stress-relieving for materials in opening connections coming under Group I, II, III or III A, when the thickness of the shell is less than 1 in., but the sum of the shell plate thickness and the reinforcement plate thickness exceeds 1 in. for NPS 12 and larger?

Reply: No.

650-I-43/00

Question: Referring to API 650, Section 3.7.4.2, must a prefabricated manhole assembly be stress relieved if the material is Group II (A 131, Grade B), the shell plate is  $\frac{3}{8}$  in. thick, and the opening is a 24-in. diameter manhole?

Reply: No, because the shell is less than 1 in. thick.

650-I-47/00

Question: Does API 650, Section 3.7.6.1, permit making a hot tapping connection on a blind flange on a nozzle in a tank?

Reply: No. Refer to API 650, Section 3.8.3, for rules on installing a nozzle in a cover plate in a new tank. Refer to API 653, Section 7.14, for rules and guidance on hot tapping in an in-service tank.

650-I-48/00

Question: Does API 650 define a “neck” as piping or nozzle passing through the shell of the tank to the first flange, regardless of the length and configuration (such as an upturned pipe connected by an elbow and another short piece pipe to the first flange) of this pipe?

Reply: No. API does not define this term. Also, refer to Section 1.2, which defines the limits of applicability on piping.

### SECTION 3.8 SHELL ATTACHMENTS AND TANK APPURTENANCES

650-I-51/00

Question: API 650, Section 3.8.3.2, requires mixer manway bolting flanges to be 40% thicker than the values shown in Table 3-3. Footnote b under Table 3-4 requires the minimum manway neck thickness to be the lesser of the flange thickness or the shell plate. Is it therefore required that the minimum neck thickness on a mixer manway be the lesser of 140% of the flange thickness value in Table 3-3 or the shell thickness?

Reply: No.

650-I-53/00

Question: Referring to API 650, is magnetic particle testing applicable for inspecting permanent attachments to the shell and at temporary attachment removal areas, when the material group is of Group I (A 283, Grade C)?

Reply: No. See 3.8.1.2 and 5.2.3.5, in Addendum 1 to the 10th Edition of API 650.

### SECTION 3.9 TOP AND INTERMEDIATE WIND GIRDERS

650-I-39/99

Question 1: Is it acceptable for the primary (upper) bottom, of an API 650 Appendix I double-bottom tank to not project through the shell and to be attached only to the inside of the shell?

Reply 1: No. API 650, Section 3.4.2 requires the bottom plate project at least 25 mm (1 in.) outside the toe of the outer shell-to-bottom weld. Section 3.5.2 requires the annular plate project at least 50 mm (2 in.) outside the shell. Furthermore, Section 3.1.5.7 requires the bottom be welded to the shell on both sides of the shell. The only way this can be accomplished is with a shell projection. Figure I-4 illustrates an acceptable double-bottom installation.

Question 2: What is the function of asphalt-impregnated board written as “optional”?

Reply 2: The function of the asphalt-impregnated board is to minimize water infiltration underneath the tank bottom and corrosion of the portion of the tank bottom in direct contact with the concrete ringwall.

Question 3: What is the expected effect on tank annular plates if the asphalt-impregnated board is not installed?

Reply 3: See reply to Question 1.

**SECTION 3.10 ROOFS**

650-I-51/99

Question 1: In API 650, Section 3.10.5, is the calculated minimum thickness the actual required thickness that takes into account the span of unstiffened cone plates with a total load of 45 lbf/ft<sup>2</sup>?

Reply 1: Yes, it is the minimum required thickness, exclusive of corrosion allowance, for the tank diameter and roof slope under consideration. It should be noted that the maximum allowable roof plate thickness limits the tank diameter as a function of the roof slope.

Question 2: How is the minimum thickness used?

Reply 2: API does not act as a consultant on specific engineering problems or on the general understanding or application of its standards. API's activities in regard to technical inquiries are limited strictly to interpretations of the standard and to the consideration of revisions to the present standard based on new data or technology.

650-I-52/99

Question: Is welding of the main roof support members to the roof plates allowed by the standard?

Reply: No, see API 650, Section 3.10.2.3 that states that roof plates of supported cone roofs shall not be attached to the supporting members.

**SECTION 5.2 DETAILS OF WELDING**

650-I-11/00

Question 1: Does API 650 Section 5.2.1.10 require the use of low hydrogen electrodes when making manual horizontal welds between two shell plates when both plates are in Groups I-III, one plate is greater than 12.5 mm (0.5 in.) thick and the other plate is 12.5 mm (0.5 in.) thick or less?

Reply 1: Yes.

Question 2: Does API 650 Section 5.2.1.10 require the use of low hydrogen electrodes when making manual welds between the shell and bottom plates when both plates are in Groups I-III, the shell plate is greater than 12.5 mm (0.5 in.) thick and the tank bottom plate is 12.5 mm (0.5 in.) thick or less?

Reply 2: Yes.

Question 3: Does API 650 Section 5.2.1.10 require low hydrogen electrodes when making welds between two annular plates that are 12.5 mm thick or less and are made of material in Groups I-III.

Reply 3: No. This question will be referred to the appropriate Subcommittee to confirm this is the desired requirement.

650-I-28/00

Question 1: Referring to API 650, Section 5.2.2.1, is the tank manufacturer allowed to set the sequence of welding the floor plates, if the sequence has been found by the manufacturer to yield the least distortion from shrinkage?

Reply 1: Yes, see Section 5.2.2.1.

Question 2: If bottom plate seams are left open for shrinkage, then must the shell-to-bottom corner weld be practically complete prior to making the welds left open for shrinkage compensation?

Reply 2: Yes, see Section 5.2.2.2.

**SECTION 5.3 INSPECTING, TESTING, AND REPAIRS**

650-I-16/00

Question: Regarding the hydrotesting of a tank to be lined internally, does API 650 require the tank to be filled with water before and after the lining is installed, or only before the lining is installed, or only after the lining is installed?

Reply: API 650 does not cover this issue. API does not provide consulting advice on issues that are not addressed in API 650.

650-I-21/00

Question 1: Does API 650 require any additional testing beyond the hydrostatic (water) test specified in Section 5.3.6 for a tank designed for product with specific gravity greater than 1?

Reply 1: No. Section F.7.6 provides additional requirements for Appendix F tanks. The purchaser may require more stringent testing as a supplemental requirement.

Question 2: Given the following conditions: nominal diameter of the tank—30 m, height of shell—18.4 m, roof—torospherical, specific gravity of content—1.32, top gauge pressure—0. Can the design calculation for test condition be executed on API 650 and Appendix F (design pressure on bottom level 233 CPA or more)?

Reply 2: API does not provide consulting on specific engineering problems or on the general understanding and application of its standards. We can only provide interpretations of API 650 requirements. Please refer to Appendix D and restate your inquiry so that it poses a question on the meaning of a requirement in API 650.

650-I-33/00

Question: Does API 650, Section 5.3.6, prohibit starting the water filling for hydrostatic testing while completing some welded attachments on the last shell ring above the water level?

Reply: No.

650-I-12/01

Question 1: Does API 650 require that tolerances (plumbness/peaking bending/roundness) be checked after the construction of each shell course, rather than after the completion of the entire shell?

Reply 1: These tolerances must be measured by the purchaser's inspector at anytime prior to the hydrostatic test. See Sections 4.2.3, 5.3.1.2, and 5.5.6.

Question 2: If repairs are required to meet the specified tolerances, when must the repairs be made?

Reply 2: API 650 does not address the timing of these repairs.

## SECTION 5.4 REPAIRS TO WELDS

650-I-48/99

Question 1: If welds in a non-radiographed tank (e.g., per Appendix A) are examined by visual examination and determined to be defective, does API 650 permit the purchaser to then require radiographic examination of the welds?

Reply 1: Section 5.4.1 requires that the purchaser's inspector approve the plan to resolve the problem. The ramifications of any upgrade to the NDE procedure originally required, such as radiographing the welds in this case, become a contractual matter.

Question 2: For purchaser-specified NDE, if required to resolve a visual finding, what acceptance criteria applies?

Reply 2: This is a contractual matter not covered by API 650.

## SECTION 5.5 DIMENSIONAL TOLERANCES

650-I-24/00

Question: API 650 gives tolerances for plumbness and roundness, but these are related to the tank shell. Are there any defined tolerances on the tank roof, such as on the rim space dimension?

Reply: No.

650-I-29/00

Question: Does the phrase in Section 5.5.5.2.a of API 650, “the top of the ring wall shall be level within +/- 3mm (<sup>1</sup>/<sub>8</sub> in.) in any 9 m (30 ft) of the circumference”, mean that the ring wall upper plane position is to be between two horizontal planes 6 mm apart or 3 mm apart?

Reply: 6 mm apart.

650-I-40/00

Question: For tanks built to API 650 and complying with Section 5.5 dimensional tolerances and subsequently commissioned, do the minimum requirements of API 650 with respect to plumbness, banding, etc., still apply after a tank has been placed in service?

Reply: No. API 650 covers the design and construction of new tanks. Any tolerance rules that might apply after the tank has been placed in service, typically API 653 plus any supplemental owner requirements, are to be determined by the local jurisdiction and the tank owner. See API 653, 1.1.1, Section 8, and 10.5.2, for further information and for some examples.

650-I-07/01

Question 1: API 650, Section 5.5.1, states that the tolerances as specified may be waived by (agreement between the purchaser and the manufacturer). If a tank does not meet the specified tolerance with regards to one specific area such as the roundness but has met the tolerance in relation to plumbness and local deviation as well as all the testing requirements such as radiography and hydrotesting, can the manufacturer insist that the purchaser accept the tank?

Reply 1: No. Agreement by both parties is required.

Question 2: Since Section 5.5.1 states that the purpose of the tolerances as specified is for appearance and to permit proper functioning of floating roofs, is it therefore correct to conclude that the purchaser has no right to refuse to accept a tank which has passed all tests required by API 650 but may have some out-of-tolerance in one or more areas?

Reply 2: No.

Question 3: An inspection measurement shows a maximum out of roundness of 28 mm on the uppermost shell course at three locations in a tank. Is this detrimental to the structural integrity of the tank?

Reply 3: API can only provide interpretations of API 650 requirements or consider revisions to the standard based on new data or technology. API does not provide consulting on specific engineering problems or on the general understanding of its standards.

650-I-08/01

Question: Does the 10th Edition of API 650 specify tolerances for the elevation and orientation of shell nozzles?

Reply: No.

## SECTION 6 METHODS OF INSPECTING JOINTS

650-I-47/99

Question: Does API 650 allow the purchaser to require radiographic examination as a requirement for acceptance after fabrication on a tank that is not required to be radiographed per API 650 rules?

Reply: API 650 does not prohibit the purchaser from specifying additional requirements. These are contractual issues outside the scope of the document.

Reply 2: This is a contractual matter not covered by API 650.

**SECTION 8.1 NAMEPLATES**

650-I-49/00

Question: For a tank built to the 10th Edition, 1st Addendum, of API 650, is it acceptable to mark “November 1998” in the Edition box and “X” in the “Revision No.” box on the nameplate?

Reply: No. The marks should be the “month and year” of the Edition in the first box, and the number of the addendum revision in the second box (e.g., 0, 1, 2).

**APPENDIX E SEISMIC DESIGN OF STORAGE TANKS**

650-I-44/99

Question 1: Do the changes to Chapter 16, Division IV Earthquake Design, of the 1997 Uniform Building Code affect API 650, Appendix E requirements?

Reply 1: The committee is currently considering changes to Appendix E as a result of the revisions to the Uniform Building Code. Approved changes will appear in future addenda of API 650.

Question 2: Why is the Seismic Zone Map of the United States shown in API 650, Appendix E slightly different for that shown on page 2-37 of the 1997 Uniform Building Code, Figure 16-2?

Reply 2: The committee is currently considering changes to Appendix E as a result of the revisions to the Uniform Building Code. Approved changes will appear in a future addendum or edition of API 650.

650-I-45/99

Question: Is the value obtained from the equation in E.4.2 equal to the dimension measured radially inward from the interior face of the shell to the end of the annular plate (the “end of the annular plate” is defined here as the inner edge/perimeter of the typical lap joint between the bottom and the annular plate)?

Reply: No, the dimension is measured radially inward from the interior face of the shell to the end of the annular plate, defined as the inner edge of the annular plate. The extent of the overlap of the bottom plate on the annular plate is not a significant consideration.

650-I-25/00

Question 1: Should the metric formula for calculating the natural period of the first sloshing mode in Section E.3.3.2 read:

$$T = k(D^{0.5})\left(\frac{1}{0.5521}\right)$$

Reply 1: Yes. This correction will appear in Addendum 2 of API 650.

Question 2: Should the metric formula for calculating the width of the thicker plate under the shell in Section E.4.2 read:

$$0.1745 \times 10^{-3} w_L / GH(m)$$

Reply 2: Yes. This correction will appear in Addendum 2 of API 650.

Question 3: Is the following revision to Section E.5.1 appropriate?

“When  $M/[D^2 (w_f + w_L)]$  is greater than 1.57 or when  $b/1000t$  ( $b/12t$ ) is greater than  $F_a$  (see E.5.3), the tank is structurally unstable.”

Reply 3: Yes. This correction will appear in Addendum 2 of API 650.

Question 4: Is the following revision to Section E.5.3 appropriate?

“The maximum longitudinal compressive stress in the shell  $b/1000t$  ( $b/12t$ ), shall not exceed the maximum allowable stress,  $F_a$ , determined by the following formulas for  $F_a$ , which take in to account...”

Reply 4: Yes. This correction was made in Addendum 1 of API 650, released in March 2000.

## APPENDIX F DESIGN OF TANKS FOR SMALL INTERNAL PRESSURES

650-I-12/00

Question: Assume a tank is to be designed to API 650, Appendix F.1.2, (the internal pressure will be greater than the weight of the roof plates but less than the weight of the shell, roof and framing). In addition, assume anchors are to be added for some reason other than internal pressure, for example: seismic, wind, sliding, overturning or user mandated. Does the tank have to be designed to API 650 Section F.7?

Reply: No, only Sections F.2 through F.6 apply. Section 3.11 applies to anchors that resist wind overturning when specified by the purchaser. Appendix E applies to anchors provided for seismic. API's Subcommittee on Pressure Vessels and Tanks is currently reviewing API 650 anchor requirements.

## APPENDIX H INTERNAL FLOATING ROOFS

650-I-50/99

Question 1: Does API 650 require that floating roof seals be installed prior to hydrotesting the tank?

Reply 1: No.

Question 2: Is a roof seal considered a major component of the tank?

Reply 2: API 650 does not use the term "major component".

650-I-10/00

Question: Does API 650 provide a way to obtain a frangible roof connection on a small tank describe as follows?

- Diameter: 8 ft.
- Height: 10 ft.
- Cross sectional area of the roof-to-shell junction "A": larger than that allowed by the equation in Section 3.10.

Reply: No. The API Subcommittee on Pressure Vessels and Tanks is currently reviewing the design criteria for frangible roof joints. You may wish to review Publication 937 *Evaluation of Design Criteria for Storage Tanks with Frangible Roof Joints*.

## APPENDIX S AUSTENITIC STAINLESS STEEL STORAGE TANKS

650-I-19/00

Question: In my opinion, the formulas given for shell thickness calculation for stainless steel materials in Appendix S, Par. S.3.2 include the corrosion allowance (CA) at the wrong place. The formulas should consist of two parts, the second part should be the CA without the division by  $S_d \times E$ .

Reply: Yes, you are correct. This typographical error was corrected in Addendum 1 to API 650, 10th Edition.



Additional copies are available through Global Engineering Documents at (800) 854-7179 or (303) 397-7956

Information about API Publications, Programs and Services is available on the World Wide Web at: <http://www.api.org>



**American  
Petroleum  
Institute**

1220 L Street, Northwest  
Washington, D.C. 20005-4070  
202-682-8000

Product No. C650A2